

Radio-Electronics

60c ■ DEC. 1966

TELEVISION • SERVICING • HIGH FIDELITY

HUGO GERNSBACK, Editor-in-Chief

GERNSBACK PUBLICATION

Do-It-Yourself
Electronic Steering
Peppy Auto Radio

R

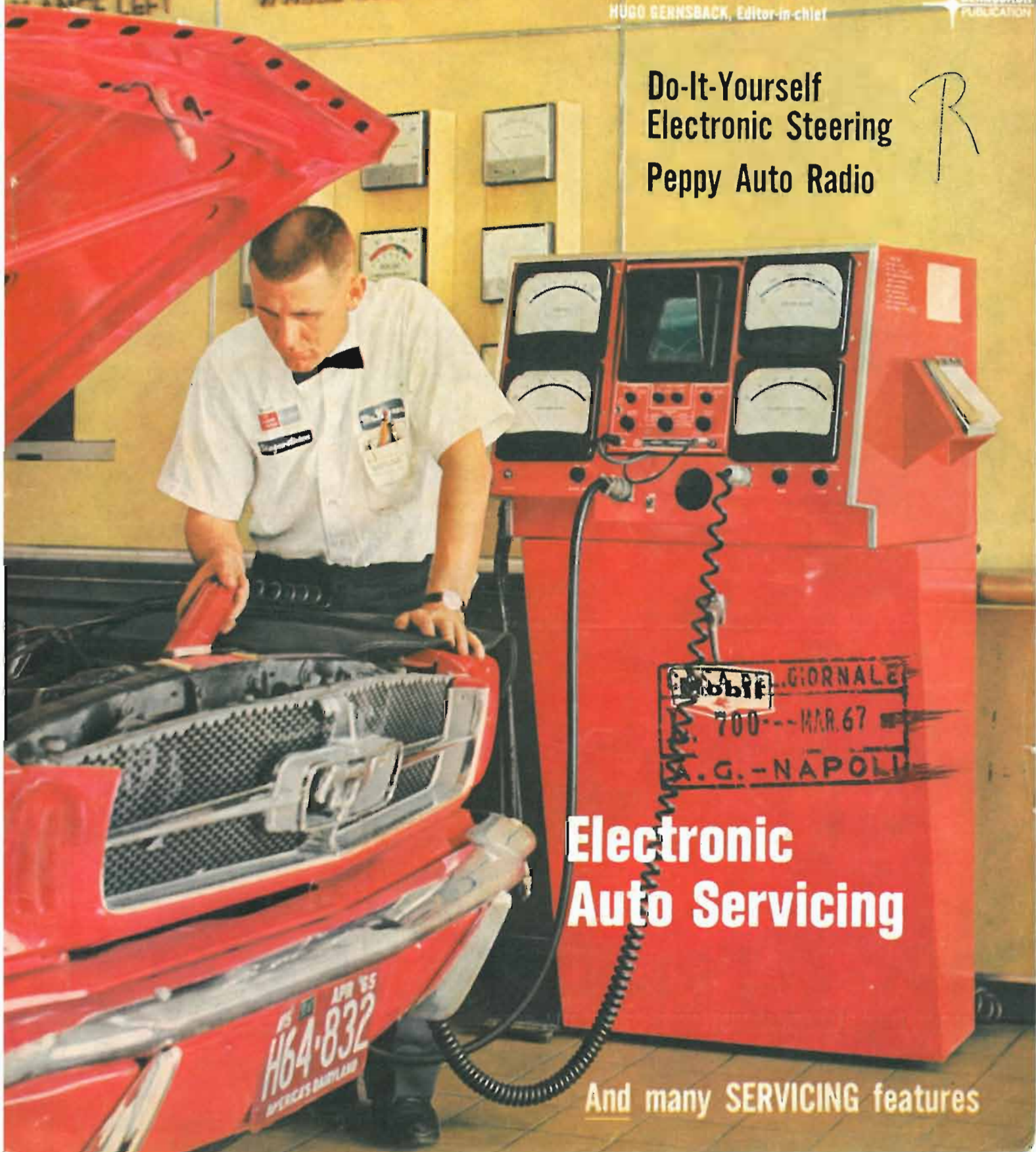

Electronic
Auto Servicing

And many SERVICING features

**WORLD'S LARGEST SELLING
AND WORLD'S NEWEST**

Hand Size V-O-M's



MODEL 310
World's Largest Selling
Volt-Ohm-Milliammeter

MODEL 310-C
World's Newest
Volt-Ohm-Milliammeter



**BOTH TESTERS
SHOWN
ACTUAL SIZE**

- 1** **HAND SIZE AND LIGHTWEIGHT**, but with the features of full-size V-O-M's.
- 2** **20,000 OHMS PER VOLT DC; 5,000 AC (310)—15,000 AC (310-C).**
- 3** **EXCLUSIVE SINGLE SELECTOR SWITCH** speeds circuit and range settings. The first miniature V-O-M's with this exclusive feature for quick, fool-proof selection of all ranges.

SELF-SHIELDED Bar-Ring instrument; permits checking in strong magnetic fields. FITTING INTERCHANGEABLE test prod tip into top of tester makes it the common probe, thereby freeing one hand. UNBREAKABLE plastic meter window. BANANA-TYPE JACKS—positive connection and long life.

Model 310—\$40.00 Model 310-C—\$50.00 Model 369 Leather Case—\$3.50

ALL PRICES ARE SUGGESTED U.S.A. USER NET, SUBJECT TO CHANGE

THE TRIPLET ELECTRICAL INSTRUMENT COMPANY, BLUFFTON, OHIO
Circle 7 on reader's service card

310-C PLUS FEATURES

1. Fully enclosed lever range switch
2. 15,000 Ohms per volt AC (20,000 O/V DC same as 310)
3. Reversing switch for DC measurements

MODELS 100 AND 100-C

Comprehensive test sets. Model 100 includes: Model 310 V-O-M, Model 10 Clamp-on Ammeter Adapter; Model 101 Line Separator; Model 379 Leather Case; Model 311 leads. (\$73.50 Value Separate Unit Purchase Price.)

MODEL 100—U.S.A. User Net. \$70.00
MODEL 100-C—
Same as above, but
with Model 310-C.
Net.\$80.00



USES UNLIMITED: FIELD ENGINEERS • ELECTRICAL, RADIO, TV, AND APPLIANCE SERVICEMEN • ELECTRICAL CONTRACTORS • FACTORY MAINTENANCE MEN • ELECTRONIC TECHNICIANS • HOME OWNERS, HOBBYISTS
THE WORLD'S MOST COMPLETE LINE OF V-O-M'S • AVAILABLE FROM YOUR TRIPLET DISTRIBUTOR'S STOCK

A New Electronics Slide Rule with Self-Training Course

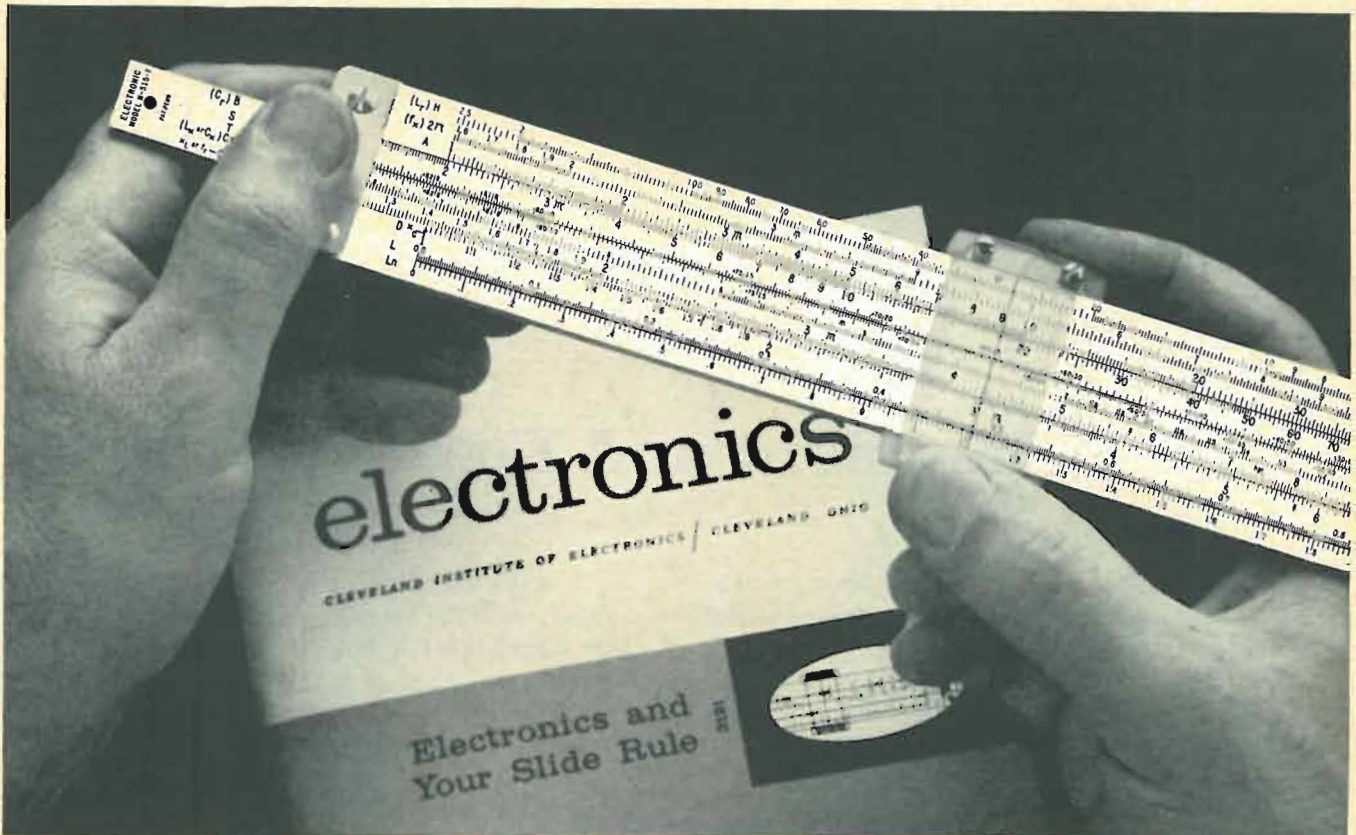

Why didn't someone think of this before?

Here's a great *new* way to solve electronic problems accurately . . . easily. The Cleveland Institute Electronics Slide Rule* is the only rule designed specifically for the exacting requirements of electronics computation. It comes complete with an illustrated Instruction Course consisting of four AUTO-PROGRAMMED* lessons . . . each with a short quiz you can send in for grading and consultation by CIE's expert instructors. With this personal guidance, you'll soon be solving complex electronics problems in seconds while others still struggle along with pad and pencil.

Here's what Mr. Joseph J. DeFrance, Head of the Electrical Technology Dept., New York City Community College, has to say about it:

"I was very intrigued by the 'quickie' electronics problem solutions. It is an ingenious technique. The special scales should be of decided value to any technician, engineer, or student. The CIE slide rule is a natural."

See for yourself. Learn how to whip through all kinds of reactance, resonance, inductance, AC and DC circuitry problems in seconds . . . become a whiz at conventional computations too!

This all-metal 10" rule is made to our tough specs by Pickett, Inc. . . . comes complete with top grain leather carrying case and Instruction Course. A \$50 value for less than \$25. Send coupon for FREE illustrated booklet and FREE Pocket Electronics Data Guide. Cleveland Institute of Electronics, 1776 E. 17th St., Dept. RE-132, Cleveland, Ohio 44114.

*TRADEMARK

GET BOTH FREE!



Cleveland Institute of Electronics

1776 E. 17th St., Dept. RE-132 • Cleveland, Ohio 44114

Please send FREE Electronics Slide Rule Booklet.

SPECIAL BONUS: Mail coupon promptly . . . get FREE Pocket Electronics Data Guide too!

Name _____ (Please Print)

Address _____ County _____

City _____ State _____ Zip _____

A leader in Electronics Training . . . since 1934

Circle 8 on reader's service card

Hindsight and Foresight

Hindsight is better than foresight. So some people say. For certain, it's more accurate—particularly if you're applying it to a magazine.

In RADIO-ELECTRONICS, the past few months have shown a gradual change, inevitable when someone new sits in the Editor's chair. You've probably noticed the obvious changes that began with the June issue: new approach to covers, more informative contents page, articles less broken up, generous treatment of illustrations.

Some of you have already mentioned in letters (and a few phone calls) some of the improvements that are usually less noticeable: page layouts that make it easier to follow an article; broader coverage that widens your knowledge of electronics; more penetrating analyses of servicing problems; faster breaks with important developments, covered in depth; more useful construction projects; smoother introductions and livelier writing, which add interest to the articles.

You've all voiced your approval by buying the magazine more and more. You've justified our extra attention to detail, our extra time spent getting things just right.

Hindsight, peering into the last several months' issues, is indeed pleasant.

Foresight, however, is not so absolute. Nevertheless, it's necessary. An inside glimpse at our plans for 1967 may show you how foresight enters the picture. Part of it lies in planning, in determining far in advance the kind of articles RADIO-ELECTRONICS will carry—articles that will excite and interest you every month, all year. In addition, here are some of the actions we're taking.

- *Building up the editorial staff.* It takes people to produce a leading magazine, good people. For example, notice the new science editor's name on our masthead this month (page 6).

- *Finding new authors, and working more closely with the excellent ones we have (some of the top names in electronics).* From them, you'll see livelier stories, easier to read even when they dip into electronics deeper than ever before.

- *Improving appearance inside and out.* Not to make it pretty, but to make every page count, giving you the most information. A neat page is easier to understand than a cluttered one.

- *Moving out into the field.* Our writers and editors must know what's going on, so we can pass it along to you. Keeping ahead is important.

- *Editing more tightly for information, but loosening up for readability.* This thoughtful practice is already showing up in the pages of RADIO-ELECTRONICS.

- *Balancing carefully the mixture of articles to accurately fulfill the goal our name implies: to cover the field of electronics adequately and thoroughly, so you learn the important things going on and as much as possible about their technical side.*

- *Pioneering new and exciting ways to present electronics data to you.* You'll see at least two new types of presentation in RADIO-ELECTRONICS this year—new methods that will surprise and thrill you. (Oh, no! Not a hint, yet. But you'll recognize them.)

That's how foresight is functioning here at RADIO-ELECTRONICS. Now it's going to be your turn. You've told us what you liked and disliked this past year. Do the same next year. My staff and I will be anxious to see, when we look back next December, how much value there is in the foresight we're applying now.

Forest H. Belt

Radio-Electronics

DECEMBER 1966 VOL. XXXVII No. 12
Over 55 Years of Electronic Publishing

EDITORIAL

- 2 Hindsight and Foresight** Forest H. Belt

GENERAL

- *32 New Twist in Accurate Automotive Analysis** Allen B. Smith
Diagnosing auto performance with electronics means better preventive maintenance
- 38 WESCON and the Future Engineers** Forest H. Belt
A convention report on new devices and young ideas
- 39 Electronic System to Guide Tomorrow's Cars** ... Steven Faulstich
Automatic vehicle steering by radio control
- 42 Mobilize Your Transistor Radio** James E. Pugh, Jr.
Use it in car or out—conversion doesn't affect portability
- 53 Lights-On Reminder for Your Car** R. T. Montan'è
Simple, inexpensive way to save a battery
- 70 Equipment Report: EICO 888 "Auto Analyzer"**

TELEVISION

- 22 Service Clinic** Jack Darr
Do You See What You See?
- 36 Who's Afraid of the "Magic Wand?"** Frank Salerno
A technician finds nothing to fear in TV remote controls
- 46 Color AFC Adjustments are Really Simple** Jack Darr
Our most popular author shows how
- 54 Selling the Chassis Overhaul** Art Margolis
How to make a successful bench-job pitch

AUDIO-HIGH FIDELITY-STEREO

- 56 Removing the Mystery from Matching** ... Norman H. Crowhurst
What does a loudspeaker see when it looks back at the output stage?

ELECTRONICS

- 47 Simple Rf Proximity Detectors** Dellroye D. Darling
How the electronics "touch" is developed

RADIO

- 44 Do You Understand Squelch?** John D. Lenk
Here are the quiet facts
- 73 CB Troubleshooter's Casebook** Andrew J. Mueller
More service hints on 27-MHz rigs

TEST INSTRUMENTS

- 49 A Sample of Scope Analysis** Robert G. Middleton
Patterns tell tales. Learn what they say
- 50 An All-Purpose Sub Box** Leon Wortman
Specially adapted for transistor work
- 59 Versatile Tester for Transistors** Don Anglin
Makes solid-state evaluation easy
- 62 A Low-Cost Constant-Current Source** Clement S. Pepper
This Zener-regulated supply operates over a wide voltage range

THE DEPARTMENTS

- | | |
|--------------------------|---------------------------------|
| 89 Annual Index | 98 Noteworthy Circuits |
| 16 Correspondence | 76 Technotes |
| 99 New Books | 96 Try This One |
| 87 New Literature | 52 What's Your EQ? |
| 81 New Products | 52 50 Years Ago |
| 4 News Briefs | 78 Reader's Service Page |



p 39—SELF-STEERING

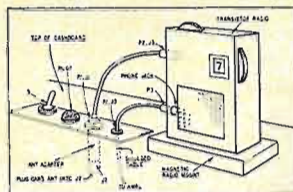

p 42—IN-CAR PORTABLE

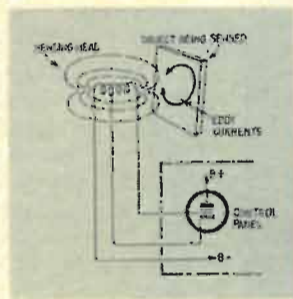

p 47—SENSING WITH RF



p 49—KNOW THAT TRACE



p 59—SEMICON CHECKER

p 62—STABLE CURRENT



RADIO-ELECTRONICS, DECEMBER 1966, Volume XXXVII, No. 12. Published monthly by Gernsback Publications, Inc., at Ferry St., Concord, N. H. 03302. Editorial, Advertising, and Executive offices: 154 West 14th Street, New York 10011. Circulation Office, Boulder, Colo. 80302.

Second-class postage paid at Concord, N. H. Printed in U.S.A. One-year subscription rate: U. S. and possessions, Canada, \$5. Pan-American countries, \$6. Other countries, \$6.50. Single copies: 60c. © 1966, by Gernsback Publications, Inc. All rights reserved. POSTMASTERS: Notices of undelivered copies (Form 3579) to Boulder, Colo. 80302.

*COVER FEATURE



p 32—A new trend is developing to keep today's cars functioning at top efficiency by using the latest and most sophisticated electronic test instruments.



p 38—Young engineering students display their ingenious projects.



Member,
Institute of High Fidelity.
Radio-Electronics is indexed in
Applied Science & Technology Index (formerly *Industrial Arts Index*)

NEWS BRIEFS

DAVID SARNOFF HONORED FOR 60 YEARS IN RADIO

Three national organizations, the Institute of Electrical and Electronic Engineers, the Electronic Industries Association and the National Associa-



tion of Broadcasters, joined in a "Salute to David Sarnoff" on the 60th anniversary of the day, Sept. 30, 1906, when he began his career as an office boy for Marconi Radio in New York City. It was the first occasion on which the three organizations had joined to honor an individual for contributions in all their fields of interest.

CHEAP SATELLITE RECEPTION PRACTICAL FOR HOME TV'S?

A television receiver could be converted for as little as \$15 to pick up programs directly from satellites, says a Virginia firm.

The Atlantic Research Corp., of Alexandria, Va., recently made a study (for NASA) of costs and technical factors in direct TV reception from satellites. Various combinations of power, signal intensity, frequencies, and background noise were considered.

Most important, concluded the study, was the power output of the satellite transmitter. To obtain adequate signal-to-noise ratio at the receiver antenna, transmitter ERP (effective radiated power) would have to be from about 10 kW to 1 GW (1 billion watts). (Early Bird's ERP is only 10 watts, and this produces a signal

much too weak for economical home reception.)

Figures were quoted for the cost of equipping 1 million receivers. For satellite ERP of 1 GW, cost could be as low as \$15 per receiver. With ERP of only 10 kW, modification cost would run from \$90 for rural use to \$180 for city use. (There is more rf noise to be overcome by the signal in urban areas.)

NEW HI-FI SYSTEMS FEATURE FIELD-EFFECT TRANSISTORS

Most striking feature of the recent New York High Fidelity Show, according to some reporters, was the dominant role of field-effect transistors in new equipment. Another new feature was the introduction of combination stereo systems including cartridge-tape players as well as conventional discs.

Visitors to the Show continued the trend of recent years—fewer apparent curiosity-seekers; a larger part of the attendance appeared to consist of couples or persons interested in purchasing a piece of hi-fi equipment and who found the Show a convenient place to see what might be available.

Another interesting feature was the industry trend toward compromise with the previously scorned "package dealers." The President of the Institute himself stated that "most components sold today are enclosed in walnut, oak, or in many cases, teak and mahogany casings. . . ."

RADICAL NEW TV "TUBE" USES LASER LIGHT BEAM

A unique experimental television display device using a gas laser instead of an electron beam to trace the picture was demonstrated in Chicago by Zenith. It is intended for use in a projection system, and a picture 2 1/4 x 3 feet was shown to viewers at the demonstration.

Light from the helium-neon gas laser first passes through an ultrasonic intensity modulator. Modulation is positive—the stronger the ultrasonic wave, the brighter the light beam.

The horizontal deflector is also ultrasonic, and represents a triumph on the part of Zenith's research team. The deflection unit is a brass tank filled with deionized water. The beam enters and leaves through glass windows at the ends. Four piezoelectric trans-

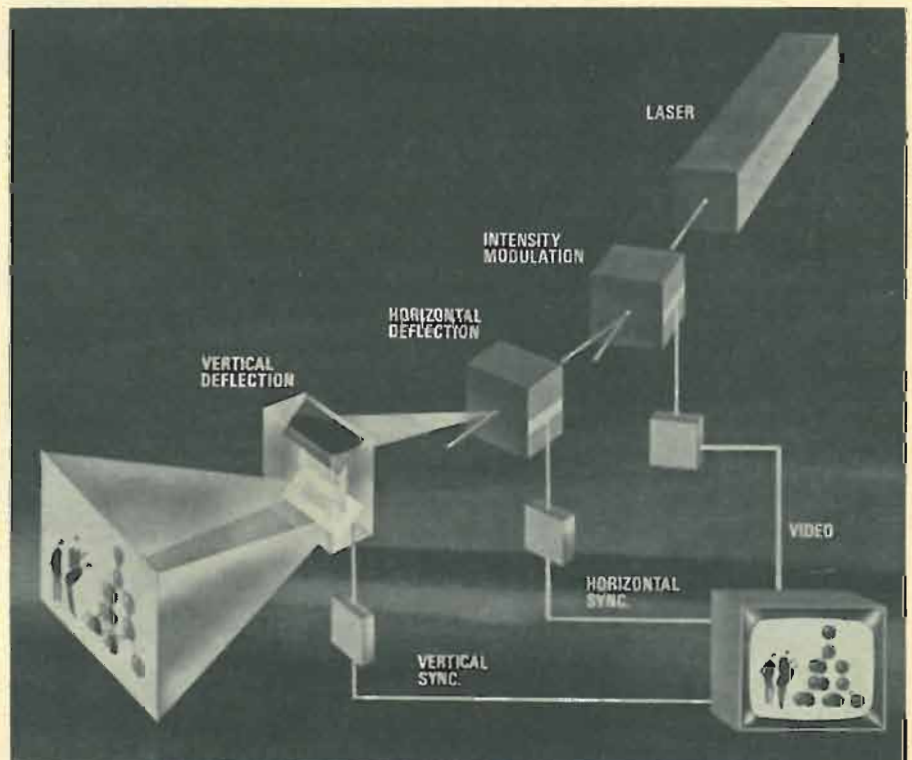

Animated block diagram of the Zenith laser television approach. An ordinary TV set was used to provide the signals and its screen utilized for monitoring displayed image.

ducers along the side of the tank intercept the light beam, deflecting over 70% of it in the desired direction at the regular television scanning frequency, 15,750 Hz. This is the first time it has been possible to deflect a light beam in this manner with ultrasonic waves.

The beam is deflected vertically by a mirror that is vibrated by a 60-Hz sawtooth wave to produce 60 fields per second. In some experiments an ultrasonic cell was also used for the vertical deflector, thus making the system all-electronic. At the low frequency required, the mechanical vibrator is entirely satisfactory, however.

Dr. Robert Adler, Zenith vice president and director of research, pointed out that the system is still in an early stage, and that more efficient lasers or other light sources must still be developed if a practical projection television is to be realized. He hoped, he said, that the demonstration of the possibilities of lasers in television would speed the development of lasers adapted to the application.

GERNSBACK'S FIRST EDITOR DIES AT AGE 78

Victor H. Laughter, editor of MODERN ELECTRICS in 1909, died in Memphis, Tenn., at the age of 78. He was stricken while at dinner in a restaurant Sept. 29 and died in the local Veterans Hospital the next day.

Laughter (whose second name, incidentally, was Hugo) was the first editor Mr. Hugo Gernsback hired; previously he had edited his magazine himself. Later Mr. Laughter became an electronics engineer specializing in electronic distribution systems for supermarkets and warehouses. He is best known to RADIO-ELECTRONICS readers for his practical work with electrets. He made and described in this magazine electrets several inches in diameter. Some of them, made in 1949, are still holding their charge. More recently (1965) he wrote articles on shop-constructed measuring instruments with special features. He was starting another article for RADIO-ELECTRONICS just before his death.

COMPUTERS TO EVALUATE TECHNICIANS' EFFICIENCY?

The National Appliance & Radio-TV Dealers Association (NARDA) is checking out the possibility of using data-processing techniques to measure the productivity of service technicians, according to Jules Steinberg, executive vice president of the Association.

A test group of about a dozen members, including service dealers of different types as well as pure service

Announcing the new line of world-famous Schober Organ Kits...

ASSEMBLE YOUR OWN ALL-TRANSISTOR SCHOBER ELECTRONIC ORGAN



All-New, All-Transistor Schober Recital Organ

- 32 voices, 6 couplers delight professional musicians...make learning easy for beginners.
- Standard console, pedals, keyboard correspond exactly to pipe-organ specifications.
- Printed circuit construction and detailed, illustrated instructions make for easy assembly...no previous experience necessary.
- Highly accurate church and theatre pipe tone in 5 pitch registers make every kind of organ music sound "right".
- Optional: Combination Action, Schober Reverbatape Unit, Repetitive Theatre Percussions.

Designed by organists for organists, the new Schober Recital Organ actually sounds like a fine pipe organ. The newly-invented Schober Library of Stops provides you with an infinite number of extra voices so that you can instantly plug in the exact voices you prefer for a particular kind of music. Thirteen-piston, instantly resettable Combination Action makes the

Recital Organ suitable for the most rigorous church and recital work. The Schober Reverbatape Unit gives you big-auditorium sound even in the smallest living room. An instrument of this caliber would cost you \$5000 to \$6000 in a store. Direct from Schober, in kit form (without optional percussions, pistons, Reverbatape Unit) costs you only \$1500.



New, All-Transistor Schober Console II

Here's the most luxurious "home-size" organ available today...with the same circuitry and musical design as the impressive Recital Organ. Full 61-note manuals, 17 pedals, 22 stops and coupler, 3 pitch registers, and authentic

theatre voicing leave little to be desired. Musically much larger than ready-made organs selling for \$1800 and more...the Console II, in kit form, costs only \$850.

HERE'S WHY YOU SHOULD BUILD A SCHOBER ORGAN!

You cannot buy a finer musical instrument for over twice the price. You get the finest in musical and mechanical quality.

It's easy to assemble a Schober Organ. If you can read and use your hands, you can easily make your own superb organ. Everything you need is furnished...including the know-how; you supply only simple tools and time—no knowledge or experience is required.

You can buy the organ section by section...so you needn't spend the whole amount at once.

You can begin playing in an hour, even if you've never played before—with the ingenious Pointer System available from Schober.

Thousands of men and women—teenagers, too—have already assembled Schober Organs. We are proud to say that many who could afford to buy any organ have chosen Schober because they preferred it musically.



New Schober Spinet

The Schober Spinet is among the very smallest genuine electronic organs; only 39 1/4 inches wide, it will fit into the smallest living room or playroom—even in a mobile home. Yet it has the same big-organ tone and almost the

same variety of voices as the larger Console II. The Schober Spinet far exceeds the musical specifications of ready-made organs selling for \$1100 and more. In easy-to-assemble kits...only \$550.

Schober Organ Kits are sold in the U.S. only by...

THE *Schober Organ* CORPORATION

43 West 61st Street, New York, N.Y., 10023
Dealers in Canada, Australia, Hong Kong, Mexico, Puerto Rico and the United Kingdom.

SEND FOR FREE SCHOBER BOOKLET

Describes the exciting Schober Organ and optional accessories in detail; it includes a FREE 7-inch "sampler" record so you can hear before you buy.

Also available:

10-inch high quality, long playing record fully illustrates all three models with different kinds of music. Price is refunded with first kit purchase...\$2.00



The Schober Organ Corp., Dept. RE-46
43 West 61st St., New York, N.Y., 10023

Please send me, without cost or obligation, the Schober Organ Booklet and free 7-inch "sampler" record.

Enclosed find \$2.00 for 10-inch quality, LP record of Schober Organ music. (\$2.00 refunded with purchase of first kit.)

Name _____

Address _____

City _____ State _____ Zip No. _____

Circle 9 on reader's service card

COMPLETE TUNER OVERHAUL

ALL MAKES—ONE PRICE

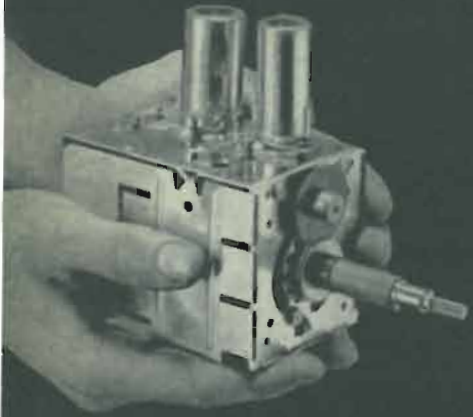

ALL LABOR AND PARTS (EXCEPT TUBES & TRANSISTORS)*

9.95



VHF



UHF



COLOR



U-V



COLOR TUNERS



TRANSISTOR

Guaranteed Color Alignment—No Addit. Charge

Simply send us the defective tuner complete; include tubes, shield cover and any damaged parts with model number and complaint. Your tuner will be expertly overhauled and returned promptly, performance restored, aligned to original standards and warranted for 90 days.

UV combination tuner must be single chassis type; dismantle tandem UHF and VHF tuners and send in the defective unit only.

Exact Replacements are available for tuners unfit for overhaul. As low as \$12.95 exchange. (Replacements are new or rebuilt.)

Experts in TV Tuner Overhauling

CASTLE

TV TUNER SERVICE, INC.

MAIN PLANT: 5715 N. Western Ave., Chicago 45, Illinois
 EAST: 41-96 Vernon Blvd., Long Island City 1, N.Y.
 IN CANADA: Castle Television Services, Ltd. . . .
 Nation-wide service

*Major Parts are additional in Canada

operators, has been assembled and is experimenting with the technique. If the idea is considered useful, the Association may offer the service nationally.

HOLOGRAPHIC RESEARCH AT NASA CENTER

Speaking at the 22nd Annual National Electronics Conference held Oct. 3, 4, and 5 at Chicago's McCormick Place, Dr. Winston Kock, former Director of NASA's Electronics Research Center in Boston, described two areas of holographic research that promise practical uses.

In the first case, the three-dimensional recording process would be used to make a series of images along the approach path to an airport runway during conditions of maximum visibility. These images would then be used in conjunction with a radar-controlled real-position computer to form a blind-landing system giving the pilot an apparent view of the approach path in full depth perspective and dimensionality, even though the actual path was fully obscured by fog or other adverse weather conditions.

In the second case, NASA scientists have constructed holograms of point-source lights that exhibit many characteristics of Fresnel and zone-plate lenses. Such holographic lenses have been used by NASA to produce photographic images. Since such a lens is flat and two-dimensional as is any photographic negative, NASA experimenters speculate that such lenses could form the optical basis for orbiting radio telescopes and focused-beam laser communication satellites. Weighing a matter of ounces, the holographic lenses could be folded to occupy extremely small spaces and later be spread in space.

OSCILLOSCOPE IMPROVES DEAF CHILDREN'S SPEECH

Deaf children in the Kendall School, Washington, D.C., are learning to speak with the help of electronic equipment. The deaf child has difficulty in pronouncing words because he cannot hear either himself or the teacher and therefore can only guess whether he sounds right or not.

Dr. Thomas Behrens, principal at Kendall, has hooked up a scope to reproduce audio signals. Then he pronounces vowels, diphthongs and difficult sounds like "sh," then lets the student watch the oscilloscope pattern and try to imitate it exactly. For practice, the instructor traces the correct outline of a sound on a piece of clear plastic taped to the tube face, and the student attempts to match it.

END

Radio-Electronics

154 WEST 14TH STREET
 NEW YORK 10011

HUGO GERNSBACK, *editor-in-chief*
 M. HARVEY GERNSBACK, *publisher*
 FOREST H. BELT, *editor*
 Bruce Ward, *production manager*
 Robert F. Scott, *W2PWG, technical editor*
 Thomas R. Haskett, *associate editor*
 Jack Darr, *service editor*
 I. Queen, *editorial associate*
 Allen B. Smith, *science editor*
 Wm. Lyon McLaughlin,
technical illustration director
 Nancy Gitchel, *editorial assistant*
 Adelaide Cassidy, *production assistant*
 G. Aliquo, *circulation manager*
 Joseph L. Bund, *newsstand director*

Cover design by Harry Schlack

RADIO-ELECTRONICS is published by Gernsback Publications, Inc.

Chairman of the Board: Hugo Gernsback
 President: M. Harvey Gernsback
 Vice President-Secretary: G. Aliquo
 Vice-President-Treasurer: Charles A. Raible

ADVERTISING REPRESENTATIVES

EAST

John J. Lamson,
 RADIO-ELECTRONICS, 154 West 14th Street,
 New York 10011, 212-255-7755

MIDWEST

P. H. Dempers Co., 5555 N. Lincoln Ave.,
 Chicago, Ill. 60625, 312-561-0220

W. COAST/TEXAS/ARKANSAS/OKLAHOMA
 J. E. Publishers Representative Co., 8380
 Melrose Ave., Los Angeles, Calif. 90069,
 213-653-5841; 420 Market St., San Francisco,
 Calif. 94111, 415-981-4527

UNITED KINGDOM

Publishing & Distributing Co., Ltd., Mitre
 House, 177 Regent St., London W.1, England

SUBSCRIPTION SERVICE: Send all subscription correspondence and orders to RADIO-ELECTRONICS, Subscription Department, Boulder, Colo. 80302. For change of address, allow six weeks, furnishing both the old and new addresses and if possible enclosing label from a recent issue.

MOVING? Or writing about subscription? Be sure to fill out form below.

For FASTEST service on address change, missing copies, etc., attach old mailing label in first space below. Otherwise please print clearly your address as we now have it.

OLO ADDRESS (Attach old label if available)

Name

Address

City State

Zip Code

NEW ADDRESS

Name

Address

City State

Zip Code

Mail to: RADIO-ELECTRONICS
 Subscription Dept. Boulder, Colo. 80302

RADIO-ELECTRONICS

◀ Circle 10 on reader's service card

ELECTRONICS

WHERE CAN YOU EQUAL THIS OPPORTUNITY

TO EARN A GOOD PAYING JOB IN A FAST GROWING FIELD?

DeVRY'S "BIG 3" AIDS TO PROGRESS ARE DESIGNED TO SPEED YOU QUICKLY TO A REAL FUTURE IN ELECTRONICS

1. EFFECTIVE TRAINING!
Learn AT HOME in spare time, or day or evening in one of our RESIDENT SCHOOLS.

2. INDUSTRY RECOGNITION!
DeVry programs, prepared with industry's help, are "JOB-AIMED."

3. EMPLOYMENT SERVICE!
for ALL graduates through our contacts with many large, respected companies across North America.

ELECTRONICS is one field that spells OPPORTUNITY in big capital letters for many men 18 to 45. This widespread but FAST GROWING field offers trained men some of today's finest, good-paying job opportunities — or a chance to start a profitable servicing shop!

Even if you don't have previous technical experience or an advanced education, DeVry's "BIG 3" aids to progress may very well be YOUR stepping stones to a BETTER FUTURE. You can learn at home in your spare time, while keeping your present job. Or, in a day or evening program in our U.S. or Canadian resident school, you can develop the very skills needed to make wonderful progress. We even work to get resident students part-time jobs to help with tuition or living expenses, if necessary!

Regardless of how you complete your educational program with DeVry, you can count on industry-recognized, effective training aimed directly at providing on-the-job-type "know-how." This is followed by actual EMPLOYMENT SERVICE to help you get started in Electronics. Or, if you are in the field already, remember that a DeVry recommendation has meant plenty of ADDED DOLLARS in income to many who made themselves more valuable to employers.

See for yourself how you, too, may prepare for the INCOME, the PRESTIGE and the FINE FUTURE that goes with the title of Electronics Technician. Mail the coupon NOW for facts without obligation.

WE PREPARE YOU NOT FOR ONE JOB BUT FOR JOBS IN MANY DIVISIONS OF THE FASCINATING FIELD OF ELECTRONICS



SPACE & MISSILE



TV — RADIO



RADAR



MICROWAVES



AUTOMATION



COMMUNICATIONS

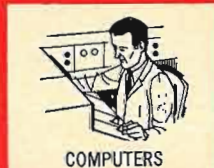

COMPUTERS



BROADCASTING



INDUSTRIAL ELECTRONICS



ELECTRONIC CONTROL

MOVIES, TEXTS AND EQUIPMENT HELP YOU LEARN FASTER

DeVry includes training movies AT HOME, "programmed" texts and many shipments of Electronic parts — to help you learn quickly, remember more.

FREE

Send coupon for these two factual booklets NOW!



MAIL COUPON TODAY!

DeVry TECHNICAL INSTITUTE

Dept. RE-12-W

4141 Belmont Avenue, Chicago, Ill. 60641

Please give me your two free booklets, "Pocket Guide to Real Earnings," and "Electronics in Space Travel"; also include details on how to prepare for a career in Electronics. I am interested in the following opportunity fields (check one or more):

- | | |
|--|---|
| <input type="checkbox"/> Space & Missile Electronics | <input type="checkbox"/> Communications |
| <input type="checkbox"/> Television and Radio | <input type="checkbox"/> Computers |
| <input type="checkbox"/> Microwaves | <input type="checkbox"/> Broadcasting |
| <input type="checkbox"/> Radar | <input type="checkbox"/> Industrial Electronics |
| <input type="checkbox"/> Automation Electronics | <input type="checkbox"/> Electronic Control |

Name _____ Age _____

Address _____ Apt. _____

City _____ State _____ Zip _____ Code _____

Check here if you are under 16 years of age.

HOME STUDY AND RESIDENT SCHOOL TRAINING AVAILABLE IN CANADA

2101

DeVry Technical Institute

4141 Belmont Avenue
Chicago, Illinois 60641

Accredited Member of National Home Study Council

Circle 11 on reader's service card



GET A FASTER START IN THE COURSE YOU CHOOSE WITH NRI'S REMARKABLE ACHIEVEMENT KIT

When you enroll with NRI we deliver to your door everything you need to make a significant start in the Electronics field of your choice. This remarkable, new starter kit is worth many times the small down payment required to start your training. And it is only the start . . . only the first example of NRI's unique ability to apply 50 years of home-study experience to the challenges of this Electronics Age. Start your training this exciting, rewarding way. No other school has anything like it. What do you get? The NRI Achievement Kit includes: your first set of easy-to-understand "bite-size" texts; a rich, vinyl desk folder to hold your training material in orderly fashion; the valuable NRI Radio-TV Electronics Dictionary; important reference texts; classroom tools like pencils, a ball-point pen, an engineer's ruler; special printed sheets for your lesson answers—even a supply of pre-addressed envelopes and your first postage stamp.

Learning electronics at home is faster, easier, more interesting with new achievement kit

Only NRI offers you this pioneering method of "3 Dimensional" home-study training in Electronics, TV-Radio . . . a remarkable teaching idea unlike anything you have ever encountered. Founded more than half a century ago—in the days of wireless—NRI pioneered the "learn-by-doing" method of home-study. Today, NRI is the oldest, largest home-study Electronics school. The NRI staff of more than 150 dedicated people has made course material entertaining and easy to grasp. NRI has simplified, organized and dramatized subject matter so that any ambitious man—regardless of his education—can effectively learn the Electronics course of his choice.

DISCOVER THE EXCITEMENT OF NRI TRAINING

Whatever your reason for wanting knowledge of Electronics, you'll find the NRI "3 Dimensional" method makes learning exciting, fast. You build, test, experiment, explore. Investigate NRI training plans, find out about the NRI Achievement Kit. Fill in and mail the postage-free card. No salesman will call. NATIONAL RADIO INSTITUTE, Electronics Division, Washington, D. C. 20016



ELECTRONICS COMES ALIVE AS YOU LEARN BY DOING WITH CUSTOM TRAINING EQUIPMENT

Nothing is as effective as learning by doing. That's why NRI puts so much emphasis on equipment, and why NRI invites comparison with equipment offered by any other school, at any price. NRI pioneered and perfected the use of special training kits to aid learning at home. You get your hands on actual parts like resistors, capacitors, tubes, condensers, wire, transistors and diodes. You build, experiment, explore, discover. You start right out building your own professional vacuum tube voltmeter with which you learn to measure voltage and current. You learn how to mount and solder parts, how to read schematic diagrams. Then, you progress to other experimental equipment until you ultimately build a TV set, an actual transmitter or a functioning computer unit (depending on the course you select). It's the practical, easy way to learn at home—the priceless “third dimension” in NRI's exclusive Electronic TV-Radio training method.

SIMPLIFIED, WELL-ILLUSTRATED “BITE-SIZE” LESSON TEXTS PROGRAM YOUR TRAINING

Lesson texts are a necessary part of training, but only a part. NRI's “bite-size” texts are as simplified, direct and well-illustrated as half a century of teaching experience can make them. The amount of material in each text, the length and design, is precisely right for home-study. NRI texts are programmed with NRI training kits to make things you read come alive. As you learn, you'll experience all the excitement of original discovery. Texts and equipment vary with the course. Choose from major training programs in TV-Radio Servicing, Industrial Electronics and Complete Communications. Or select one of seven special courses to meet specific needs. Check the courses of most interest to you on the postage-free card and mail it today for your free catalog.

Available Under
**NEW
GI BILL**

If you served since
January 31, 1955, or
are in service, check GI
line in postage-free card.

custom training kits “bite-size” texts



Technicians

Opportunities with the Rapidly Expanding IBM Components Division

Chemistry

Assignments in semiconductor process development and process manufacturing. Familiarity with encapsulation, photo-resist technology, diffusion, or vacuum deposition is preferred.

Materials

Positions are in semiconductor material preparation and failure analysis. Experience in epitaxial growth techniques or micro failure analysis is desirable.

Physics

Challenging opportunities in semiconductor device development. These positions require experience in device evaluation, high vacuum technology or diffusion techniques.

Electronics

Assignments are in semiconductor circuits and device characterization. Experience in device test techniques or familiarity with transistor circuit performance is desirable.

The Components Division is in Dutchess County, approximately 65 miles north of New York City. Liberal company paid benefits, including relocation and tuition refund.

Please write, outlining your qualifications and experience, to Mr. M. J. Mangiameli, Dept. 649Z, IBM Components Division, East Fishkill Facility, Route 52, Hopewell Junction, New York. IBM is an Equal Opportunity Employer.

IBM®



WHAT'S IN A CHIFF

Dear Editor:

In the "Service Clinic" of September 1966, Jack Darr answered the query "What is a Chiff" incorrectly.

Chiff is a patented circuit which adds a brief pulse from a higher, harmonically related tone generator to the tone being played. The resistor and capacitor form a time-constant circuit that determines the duration of the pulse. The capacitor is charged when the key is up and discharged when the key is pressed, keying the harmonic generator. The diode is used for isolation to prevent the lower note from sounding when the upper note is played.

GARRISON W. JOHNSON

Mt. Morris, Mich.

[Jack says: Thanks for your explanation of the "chiff" effect. (That's what you get when you let a drummer get loose among musicians!)]

Actually, I can't remember the exact source of the information I got; one of my "friends" who runs an organ repair shop, I think. Took me quite a while to dig it up, and I took his word for it, never having run into this exact circuit before. In general, though, it seems to have the effect that we described; at least, to the untrained ear.]

SIGHT AND SOUND OF ELECTRONICS

Dear Editor:

I read your editorial in the September 1966 issue (page 2) with considerable interest.

What is the ultimate, and therefore most important, point in all communications work? Is it not the human mind? For what other purposes—if any—should any form of communication exist, if not to get information into our minds?

But how does information of any sort get into our minds? The average human being is almost totally dependent upon his eyes and ears. If either the eye or the ear does not function properly, an avenue into the mind is fouled up! When that happens, all the work that

has been expended on every medium of communication is largely wasted.

Not nearly enough of us who make our living from some part of "The Universe of Communication" are aware of the fact, but our stake in how well people see and hear is enormous. No matter whether we design computers, manage technical publications or just fix Mrs. Jones's TV set, the ultimate purpose of everything we do is to provide things for people to see and hear. All else is only a means to that end.

Electronics has not had nearly enough to do with devices and techniques of correcting sight. The principal "weapons" against sight defects are not electronic. For the deaf, much is being done through electronics. And much more *could* be done. Whoever you are and whatever you are in electronics, you need people's eyes and ears in your business!

The average electronics engineer, technician, etc., has been a little too busy about other matters. The hearing-aid industry has become in effect an isolated little world with its own ideas about how things ought to be done, and for who. One of the most widely felt and most urgent needs of our era is for more people in electronics to become more interested in and better informed about how people hear and see.

FRANK J. WILKERSON

Charleston Heights, S. C.

HOORAY FOR OCTOBER

Dear Editor:

I've been following your magazine off and on since the 1940's. The October issue caught my eye: "Plus Industrial Electronics Section." And the cover picture is great.

The part telling about those PC's off the surplus markets (page 47) is good, too—especially Mr. Pepper's ingenious use of transparent material for tracing the circuits. This can be used on all PC's. I've got a bunch of these, and ran into the time-consuming tracing job and just let it go until I saw this. Oh, if only the boards or cards were transparent!

I was also struck by your editorial (page 2). I certainly agree with you. This is precisely why I'm in industrial electronics today. I was considering going back into TV work but the pay is not enough. One reason I considered going back is the weird circuitry I'd been running into on this job, with no explanations how it works! I prefer working on circuits I understand, and fortunately I've managed so far. I'd be going backward to return to TV.

By the way, I'm now entering my

continued on page 16

“Sure,
you work hard,
but that’s not
enough...”



**NOW!
2 NEW PROGRAMS!**
● Industrial Electronics
for Automation
● Computer Systems
Technology

...you need more education to get ahead in electronics”

No matter how hard you work, you can't really succeed in electronics without advanced, specialized technical knowledge.

Going back to school isn't easy for a man with a full-time job and family obligations. But CREI Home Study Programs make it possible for you to get the additional education you need without attending classes. You study at home, at your own pace, on your own schedule.

CREI Programs cover all important areas of electronics including communications, servomechanisms, even spacecraft tracking and control. You're sure to find a program that fits your career objectives.

You're eligible for a CREI Program if you have a high school education and work in electronics. Our FREE book gives all the facts. Mail coupon or write: CREI, Dept. 1412D, 3224 Sixteenth Street, N.W., Washington, D. C. 20010

SEND FOR FREE BOOK

“Approved for Veterans Administration Training.”



Accredited Member of the National Home Study Council



The Capitol Radio Engineering Institute

Dept. 1412-D, 3224 Sixteenth Street, N.W.
Washington, D.C. 20010

Please send me FREE book describing CREI Programs. I am employed in electronics and have a high school education.

NAME _____ AGE _____

ADDRESS _____

CITY _____ STATE _____ ZIP CODE _____

EMPLOYED BY _____ G. I. BILL

TYPE OF PRESENT WORK _____

- I am interested in Electronic Engineering Technology
 Space Electronics Nuclear Engineering Technology
 NEW! Industrial Electronics for Automation
 NEW! Computer Systems Technology

assault on perfect

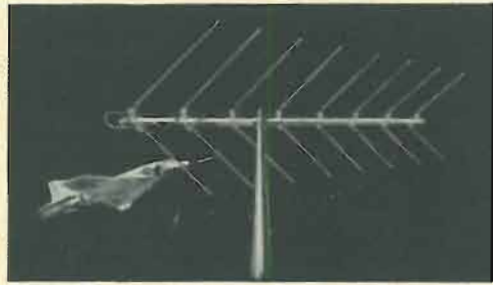

Back in 1962, we invented a new kind of TV antenna.

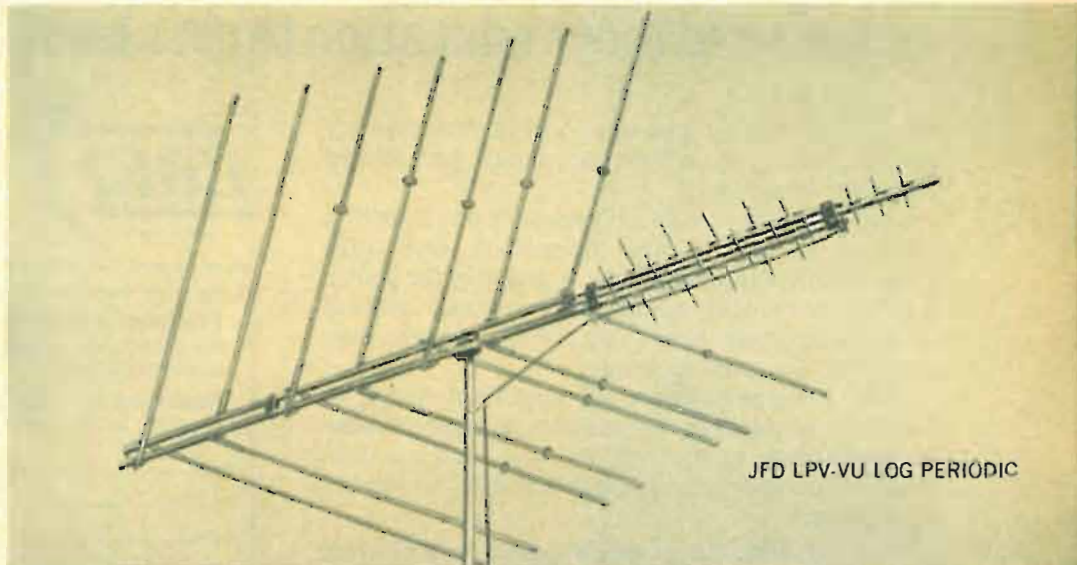

Licensed under one or more of U.S. patents 2,958,081; 2,985,879; 3,011,168; 3,108,280; 3,150,376; 3,210,767, RE. 25,740 and additional patents pending in U.S.A. and Canada. Produced by JFD Electronics Co. under exclusive license from the University of Illinois Foundation.

Circle 14 on reader's service card

tion: PERFECTION CONQUERED

We did not improve on an old antenna. We started from scratch to design a new one. *Really new.*

It wasn't easy. And it wasn't cheap. But it worked like mad.

We called it the LPV Log Periodic. Its performance caught our competitors with their charts down. But it wasn't long before they came up with LPV copies in every way—except in performance.

Meanwhile back at the JFD labs in Champaign, Illinois, our scientists and engineers continued their "assault on perfection." In 1963, they again shattered antenna precedent by coming up with the *first* combination VHF/UHF/FM log periodic antenna, the LPV-VU. Instead of three different antennas, installers now needed only *one* LPV-VU and *one* downlead.

Our competitors scoffed at the idea. They said it couldn't be done. Until the "eyepopping" results started to roll in. Then there was a mad scramble for the LPV-VU bandwagon.

These "me-too" antennas looked like the LPV-VU Log Periodic. Sounded like it, too. But their charms were skin-deep.

Only the JFD LPV-VU delivered deluxe 82-channel log periodic performance. Because only the JFD LPV-VU followed the genuine patented log periodic concept of the University of Illinois Antenna Research Laboratories. Thanks to the protection of eleven different LPV-VU U.S. patents issued and pending—more than those of any other antenna.

You would think by now our Research and Development people in Champaign would leave well enough alone. But no. These "Young Turks" have gone and done it again. This time it's a new all-band log periodic design—the LPV-CL Color Laser. (Must be that "assault on perfection" bug they've still got up their polinear recorder.)

Why did we call it the Color Laser?

Well, engineers tell us that laser light beams with their tremendous bandwidth capacity are the communications carrier of the future. And we believe that our new VHF/UHF/FM Color Laser with its extreme bandwidth, among other unique characteristics, is the antenna of the future—only it's available to you *now*. How does the Color Laser deliver unsurpassed natural color, black and white across 82 channels, and FM, too?

Three reasons: (1) *Patented *VHF "cap-electronic" Log Periodic V Design*, (2) a new

broad band UHF "zoned" trapezoid driver, (3) a new *disc-on-rod UHF director system*. And there are patents issued and pending on all three.

We've also spun off the LPV "cap-electronic" Log Periodic section of the Color Laser. It forms the heart of a great new VHF antenna series we've named the LPV-TV.

This "assault on perfection" of ours involved a complete new mechanical design, as well. Results: "fast-lock" element brackets, "hot" twin booms (no lossy harnesses or transformers), new super-strength double U-bolt profiles, high reliability cylindrical capacitors, plus our electrically conductive gold alodized aluminum.

If you're the breed of professional contract installer or self-servicing appliance dealer who *never* settles for less than the best, we have a suggestion. Use a JFD LPV-CL Color Laser or LPV-TV Color Log Periodic on your next installation. See what it feels like to install the *best* of all in performance and customer satisfaction.

You will also see why our research and development people have now changed their watchword from "assault on perfection" to "perfection conquered".

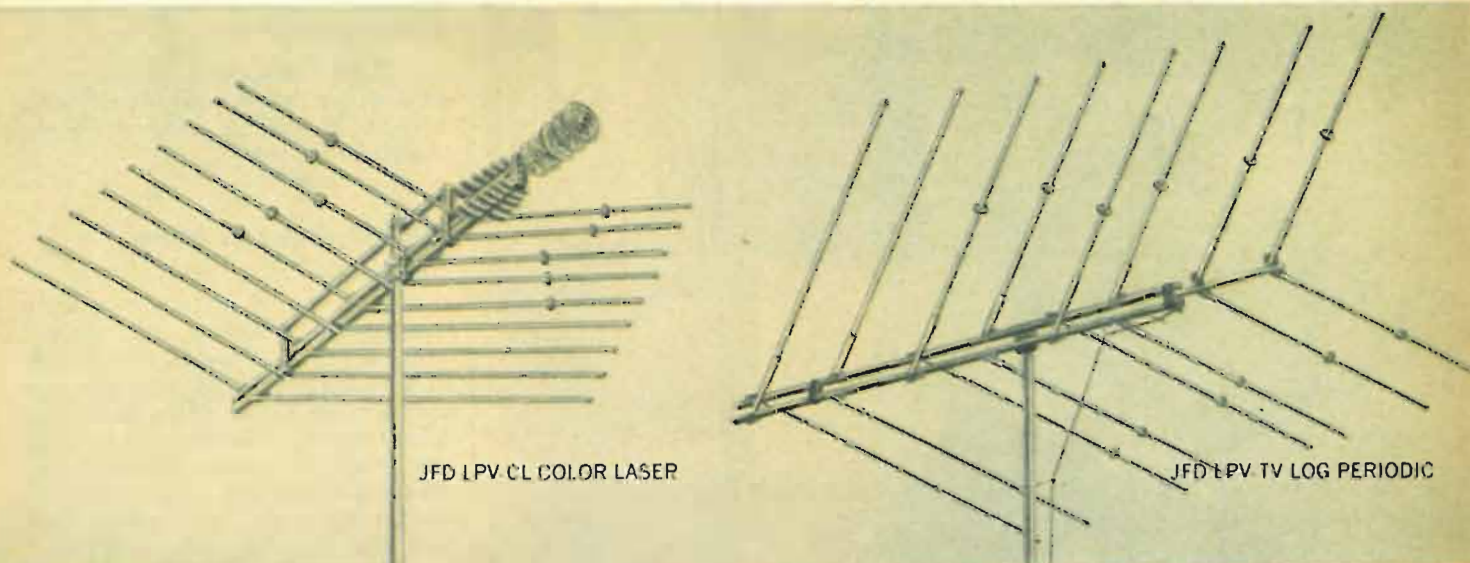

JFD LPV CL COLOR LASER

JFD LPV TV LOG PERIODIC

Licensed under one or more of U.S. Patents 2,955,287 and 3,015,821 and additional patents pending.

JFD®

JFD ELECTRONICS CO.

15th Avenue at 62nd Street, Brooklyn, N.Y. 11219

JFD International, 64-14 Woodside Ave., Woodside, N.Y. 11377 JFD Canada, Ltd., Canada

JFD de Venezuela, S.A., Avenida Los Haticos 125-97, Maracaibo, Venezuela

How "saving" 50¢ can ruin a \$700 color TV system!

The coupler is probably the least expensive item in a home TV system . . . yet the wrong coupler can send the investment in a top-quality distribution system and TV set right down the drain.

At Blonder-Tongue, the same engineering skill and meticulous quality control goes into couplers that goes into our professional MATV products. The result: high isolation between sets, extremely low insertion loss and sharp pictures (they're backmatched).

Blonder-Tongue gives you variety, too . . . the widest variety of color-approved, all-channel coupler models in the industry:

A-102U/V—deluxe 300-ohm model connects 2 sets to one download.

A-104/UV—similar to A-102U/V except for 4 sets.

MDC-2VU—connects two coax (75-ohm) cables from TV sets to a single coax download.

TV-2—economy indoor model. Connects two sets to a single 300-ohm twinlead. Not recommended for weak signal areas.

Quality combiners and splitters are also essential to a good all-channel color TV system. When you specify Blonder-Tongue, you get high quality, low loss and high isolation.

UVF-1—deluxe 300-ohm weatherproof model. Provides separate UHF, VHF and FM outlets from download carrying all three signals or feeds a single download from separate UHF, VHF and FM antennas.

UVF-C/S—a lower priced version of the UVF-1.

A-107—deluxe, weatherproof unit combines UHF and VHF antennas to one 300-ohm download or provides separate UHF and VHF output at set.

UV-C/S—indoor unit provides separate UHF and VHF outputs from a single 300-ohm cable carrying both signals, for connection to converter or TV set with separate UHF and VHF inputs.

Write for free catalog #74.

Blonder-Tongue Laboratories, Inc., 9 Alling Street, Newark, N.J.

Blonder-Tongue, the name to remember, for TV reception you'll never forget

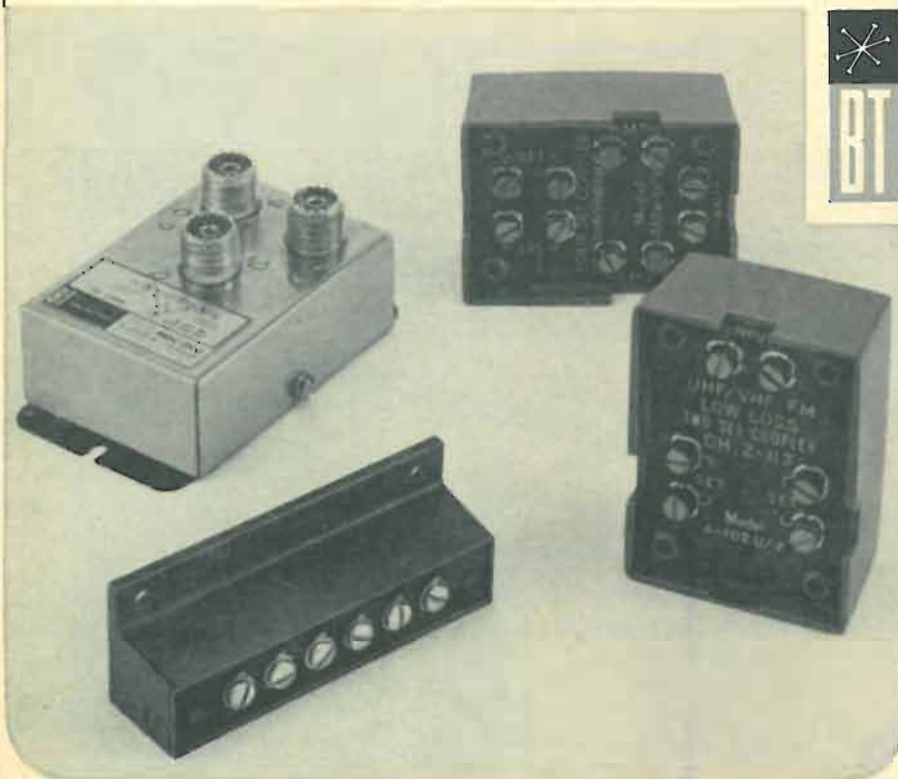

Circle 15 on reader's service card

CORRESPONDENCE continued

order for a subscription to your magazine because of your coverage of industrial electronics.

M. D. BERNARD, JR.

Merritt Island, Fla.

MORE MONEY FOR TECHNICIANS

Dear Editor:

Your editorial regarding lack of upcoming servicemen due to low salary offerings (October 1966, page 2) is only partly true. Out here on Long Island there have been some pretty good offers. I saw one in the paper just the other day of \$150-\$200 per week for a color technician, up from some older offers of \$125 a week.

What discourages a lot of men from this service occupation are the long weeks; the attitudes of too many TV owner-customers; the lack of fringe benefits (pension, hospitalization, etc.) which most small shops can't afford; the disgusting way in which these "progressive" TV sets (and radios) are engineered servicewise and qualitywise; the proliferation of tube types, most of which represent little improvement over similar older types; and on and on. With a little thought, I could fill another page.

Frankly, I don't know the answer; with all my years of association activity I couldn't find a consistent binding force among servicemen, particularly here on Long Island. The turnover of shops here is too high. Also, I am afraid that without a good business climate to keep those in business happy to stay in business, there won't be many who will be attracted to work in this servicing field.

JOHN A. WHEATON

East Williston, N.Y.

[Color technicians—good ones—get more pay almost everywhere. Proves the point of my final paragraph in the editorial.—Editor]

COINING ACOUSTIC TERMS

Dear Editor:

I like the way my article "Custom Equalization Enhances PA Sound" turned out in the November 1966 issue. There is an interesting sidelight your readers might like to know about. The Boner system of acoustic treatment has been given a new name: *electronic anechoicness*. As you can imagine, *physical anechoicness* would be acoustic treatment with materials, such as the damping fabrics and fibers described in the article, or by geometric auditorium design. The Boner method does the job electronically.

DON DAVIS

Altec-Lansing, Inc.
Anaheim, Cal.

END

This is the only computer in the phono cartridge business!

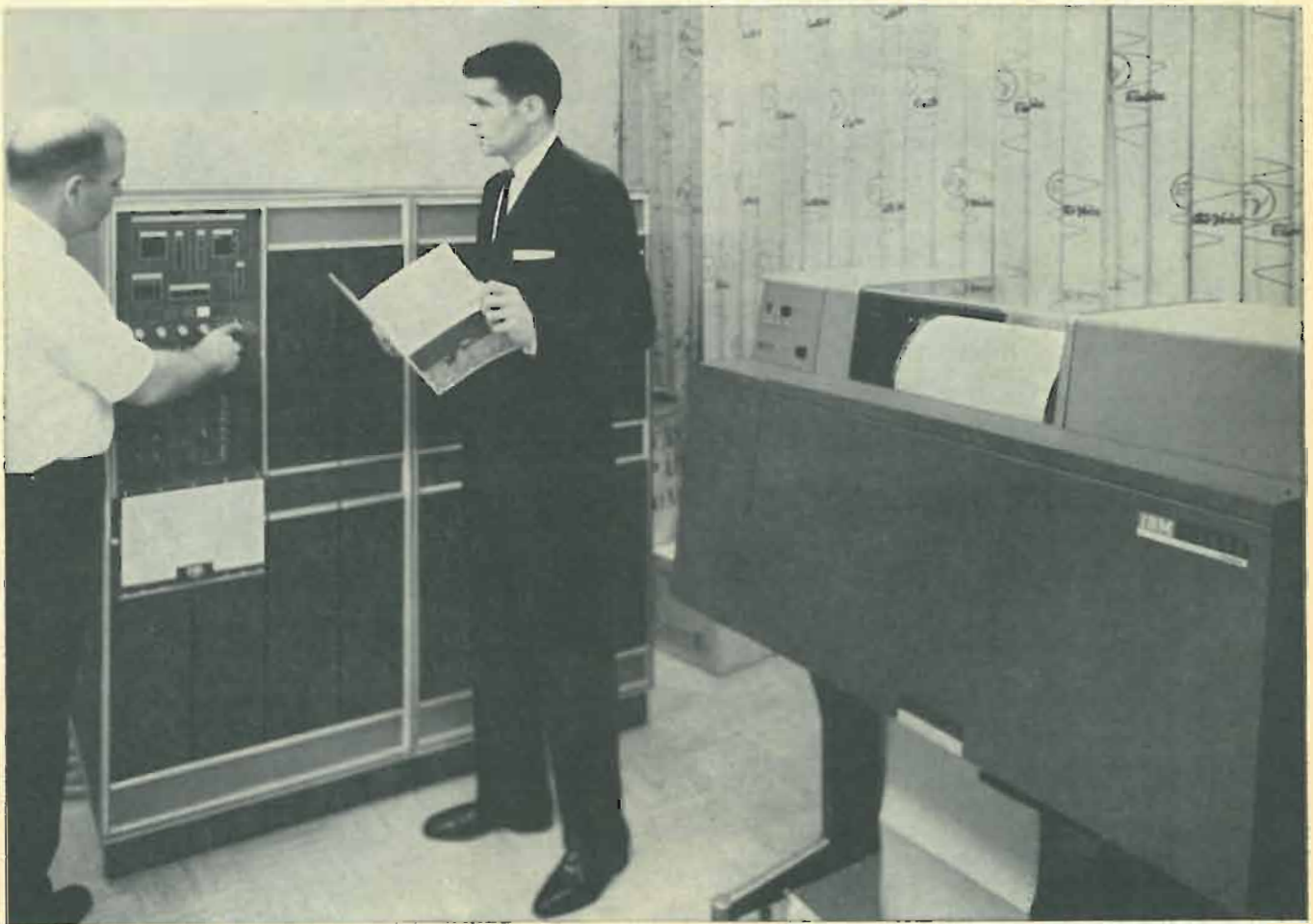

Our IBM computer tells you the exact selling ratios of every cartridge in the E-V line. No guesswork or vague "popularity" ratings.

And in its spare time it prints the most complete, accurate, up-to-date phono cartridge catalog in the business. Plus a similar needle catalog.

Isn't it time you got "on-line" with the Electro-Voice computer-controlled cartridge line?

Electro-Voice[®]

The *modern* complete line of replacement phono cartridges

ELECTRO-VOICE, INC., Dept. 1267E, 613 Cecil Street, Buchanan, Mich. 49107
Circle 16 on reader's service card

TAKE THE FIRST BIG STEP TOWARD A REWARDING CAREER IN ELECTRONICS

Mail card to RCA Institutes today

Thousands of well paid jobs for
Electronics Technicians are
unfilled now

*RCA Institutes Can Train You—
At Home—And Help You Qualify
For This Work*

It's a sad, but true, fact that today, with so many men yearning for better jobs and better incomes, thousands of well paid jobs are unfilled in the vast electronics industry.

Many of the men who could fill these jobs—that is, men with the aptitude and native interest to enjoy a career in electronics—are handicapped because for one reason or another they have not had the opportunity to train themselves for these lucrative positions.



NOW— THANKS TO RCA INSTITUTES HOME STUDY— YOU CAN TRAIN FOR A CAREER IN ELECTRONICS

Realizing that thousands of technical jobs—well paid jobs—in electronics are going unfilled each week, RCA Institutes has done something positive about the problem. To benefit the electronics industry, with its crying need for trained men . . . and to help men who really want to move into a well paid electronics job, RCA Institutes offers an ideal home training program!

HOME STUDY CAN PROVIDE CAREER OPPORTUNITIES!

To help meet the need for qualified men in the electronics field, RCA Institutes has created a wide variety of Home Training Courses, all aimed toward a profitable, exciting electronics career in the shortest possible time. Included are exclusive "Career Programs" designed to train you quickly for the job you want! Your study program is supervised by RCA Institutes experts who work with you, help guide you over any "rough spots" that may develop along the way.

OFF TO A FLYING START WITH AMAZING RCA "AUTOTEXT" METHOD

Each "Career Program" starts with the amazing "AUTOTEXT" Programmed Instruction Method — the new, faster way that's almost automatic! "AUTOTEXT" helps even those who have had trouble with conventional learning methods in the

past. It is truly the "Space Age" way to learn everything you need to know with the least amount of time and effort.

RCA INSTITUTES ENGINEERED KITS SPEED YOUR PROGRESS

To speed you on your way to a successful electronics career, your "Career Program" will include a variety of RCA Institutes engineered kits at no extra cost—each complete in itself. As a bonus, you will also receive and build a valuable Oscilloscope. You'll get the new Programmed Electronics Breadboard for limitless experiments, including building a working signal generator and a fully transistorized superheterodyne AM receiver and Multimeter.

CHOOSE YOUR CAREER PROGRAM NOW

To get a head start today on the electronics career of your choice, look over this list of RCA Institutes "Career Programs", pick the one that appeals most to you, and check it off on the attached card:

- Television Servicing
- Telecommunications
- FCC License Preparation
- Automation Electronics
- Automatic Controls
- Digital Techniques
- Industrial Electronics
- Nuclear Instrumentation
- Solid State Electronics
- Electronics Drafting

To meet other specific needs, RCA Institutes also offers a wide variety of separate courses which may be taken separately from the "Career Programs". These range from Electronics Fundamentals to Computer Programming. They are described in the material you receive.



The Most Trusted Name in Electronics

ADVANCED TRAINING TOO

If you are already working in electronics or have some experience but want to move on up, you may start RCA Institutes training at an advanced level. No tedious repetition of work you already know!

UNIQUE TUITION PLAN

With RCA Institutes, you learn at *your own pace*, and you pay only as you learn. There are no long term contracts to sign . . . no staggering down-payments to lose if you decide to stop...no badgering bills. You pay for lessons only as you order them, and should you decide to interrupt your training at any point, you may do so and not owe one cent.

CLASSROOM TRAINING AVAILABLE

RCA Institutes Resident School is one of the largest schools of its kind in New York City with classroom and laboratory training available in day or evening sessions. Coeducational classes start four times a year. Just check "Classroom Training" on the attached card for more details.

FREE PLACEMENT SERVICE, TOO!

In recent years, 9 out of 10 Resident School students who used the Free Placement Service have been placed before or shortly after graduation. This Service is now available to Home Study students.

**ALL RCA INSTITUTES COURSES
AVAILABLE UNDER NEW GI BILL.**

**SEND ATTACHED POSTAGE PAID
CARD TODAY FOR COMPLETE
INFORMATION. NO OBLIGATION.
NO SALESMAN WILL CALL.**

RCA INSTITUTES Inc. RE-D6

A Service of Radio Corporation of America
350 West 4th Street, New York, N. Y. 10014

to make "AS GOOD AS NEW"

you've got
to put in
a little



for instance

... when installing replacement speakers, it makes sense to replace with a speaker identical to the original equipment ... the speaker for which the unit was designed. This is the one sure way to maintain proper balance in a sound system.

Oxford Transducer Company manufactures the most complete line of standard replacement speakers to O.E.M. specifications, for phonographs, TV, tape recorders, and conventional and transistor radios. Oxford speakers are used by most manufacturers of consumer electronic equipment, so you are guaranteed O.E.M. standards.

All speakers are available from stock, right now. You benefit two ways: from reduced inventories, and from assured customer satisfaction.

Write today for your technical bulletin on Oxford's line of standard replacement speakers.



Full Range
of Replacement
and Commercial
Sound Speakers

**OXFORD TRANSDUCER
COMPANY**
A Division of
Oxford Electric Corporation

3911 S. Michigan Ave.
Chicago, Ill. 60653

Circle 18 on reader's service card

SERVICE CLINIC

By JACK DARR Service Editor

Do You See What You See?

THE MONEY YOU MAKE AT SERVICING IS directly related to your speed in servicing. Your speed depends on the accuracy of your diagnosis. This accuracy is a combination of your observations and *interpretations* of what you see. Take a look at a couple of typical cases, and see if you really see what you think you see.

A G-E CA color chassis is fairly bright, but badly out of focus; in fact, all you can see is a blur. Focus voltage measures about 3kV (should be 5); high voltage about 23 kV (should be 24). Fig. 1 shows a partial schematic.

Now, where to start? Well, what are the possible trouble sources: weak horizontal output tube, low B+ or boost, bad flyback, bad rectifiers, bad electrolytics and so on. So, where's the key clue? *Percentage* of error.

Notice that focus voltage is down by 40%, but high voltage is down only about 4% or 5%. Hmm ... interesting, what?

Moving the focus control (a transformer in this chassis) changes the value of focus voltage. That eliminates the focus transformer—if it were bad, there'd be no voltage variation when the core was moved. The 130-pF coupling capacitor proves okay, by test (or substitution—remember, you've got to put nearly 5 kV across it to determine leak-

This column is for your service problems—TV, radio, audio or general and industrial electronics. We answer all questions individually by mail, free of charge, and the more interesting ones will be printed here.

If you're really stuck, write us. We'll do our best to help you. Don't forget to enclose a stamped, self-addressed envelope. Write: Service Editor, Radio-Electronics, 154 West 14th Street, New York 10011.

age, and few capacitor checkers use 5 kV of test voltage!). One possibility remains—the focus rectifier.

This diode isn't easy to test, because of its high resistance. Even on the X1,000-meg scale of an ohmmeter, there's no reading through the diode, either way. So, get a new diode and measure *it*. You find a very slight reading in one way and nothing the other. This is at least a difference, so now try the best test of all—put the rectifier in the circuit.

Aha! Now there's focus voltage, up to 4.4 kV, and a nicely focused raster.

The basic principle here is that the *percentages of error* of the HV and the

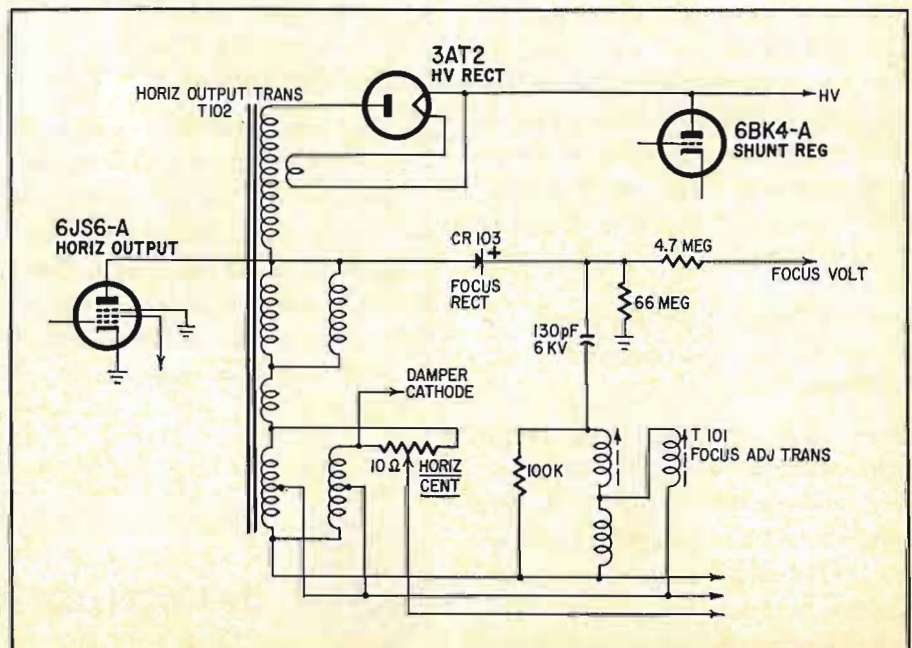

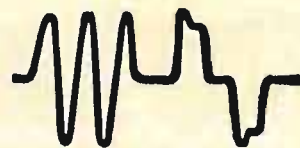

How to save trouble and money in replacing silicon rectifiers

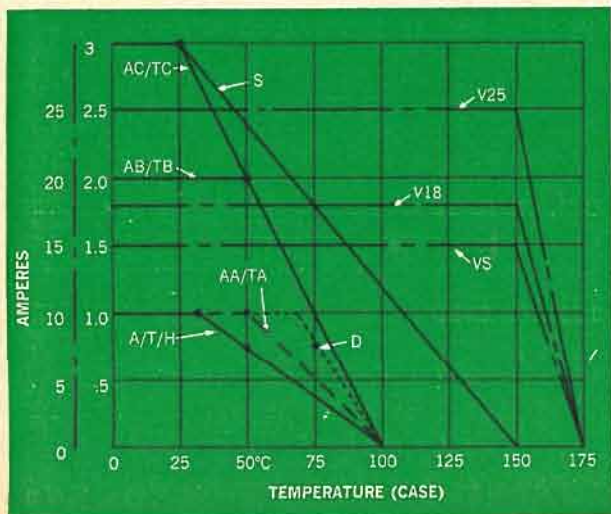
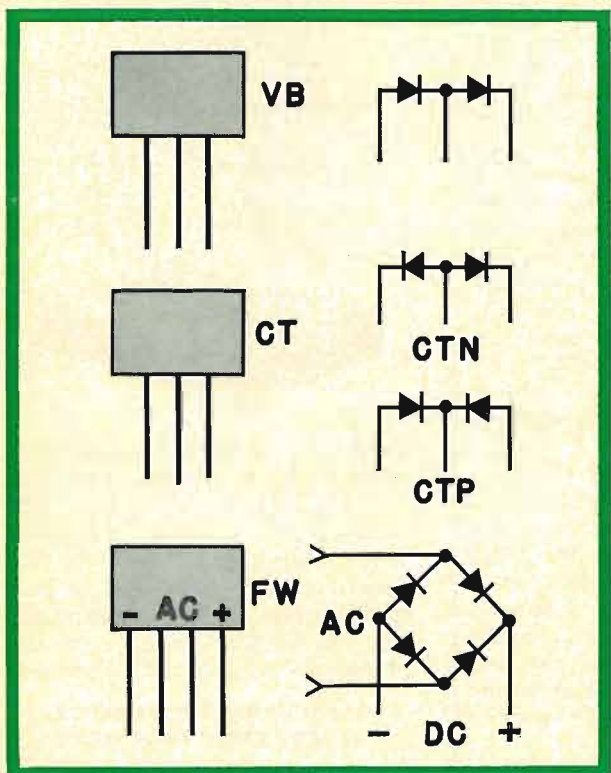
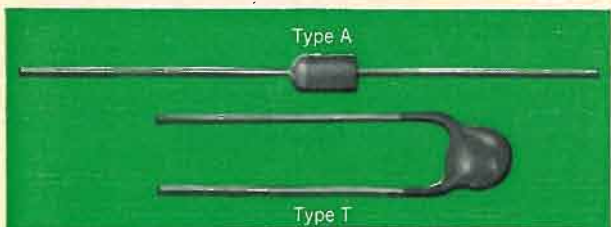

When you need to replace silicon rectifiers, it will pay you to take a look at what's available from your Mallory distributor —at new low price tags.

Suppose you need to replace a single rectifier. Some service technicians have followed an ancient adage that the only kind to use "to be sure" is a MIL top hat style. This may have been true in the pre-historic days of semiconductors (eight years or so back). But not today. Plastic-case Mallory rectifiers —Type A and Type T—are every bit as good for entertainment equipment. And they cost less, fit anywhere, are easy to mount. If you insist on a top hat, you can't get a better one than the Mallory Type H; but you don't really need it unless ambient temperatures reach the egg-frying point.

Doublers. When one leg of a doubler goes out, better check the filter capacitors first. A leaky filter or a sudden current surge could be the reason the rectifier failed. Our tip: replace the whole doubler—to make sure you won't get a call-back if the other half had been pushed beyond its limit and was ready to fail. Easiest way to do the job is to install a Mallory VB doubler package. These encapsulated units consist of a pair of factory-connected, matched rectifiers in series. Just three leads to connect instead of four. And the cost is less than that of two separate rectifiers.

The same deal goes for center-tap rectifiers. Our CT packages, in either positive or negative center tap configurations, give you the assurance of matched rectifier characteristics. Savings are identical with what you get on doubler packages.

How about full-wave bridges? You'll find a lot of these in sound equipment, so all the more reason to make sure that you deliver a top quality replacement job. It's a cinch to replace four separate rectifiers with a Mallory Type FW package—a neat encapsulated unit with only four leads to worry about instead of eight, and with four matched rectifiers factory-connected inside. And the cost is substantially less than four separate rectifiers.

And best of all, when you use Mallory rectifiers, you're sure of getting best OEM quality. The convenient way to find out what Mallory rectifier to use is to get a copy of the new Silicon Rectifier Cross Reference booklet, available from your Mallory distributor. It tells you the recommended Mallory replacement for original part numbers of 23 of the most popular TV manufacturers. Mallory Distributor Products Company, a division of P. R. Mallory & Co., Indianapolis, Indiana 46206.

Circle 19 on reader's service card

50th
ANNIVERSARY

NEW

"tray biens" most versatile of all nutdriver sets

Handy "Tray Bien" sets lie flat or sit up on a bench, hang securely on a wall, pack neatly in a tool caddy.

Lightweight, durable, molded plastic trays feature fold-away stands, wall mounting holes, and a snap lock arrangement that holds tools firmly, yet permits easy removal.

Professional quality Xcelite nutdrivers have color coded, shockproof, breakproof, plastic (UL) handles; precision fit, case-hardened sockets.

Hangs up



Stands up



Holds tools
securely

No. 127TB "Tray Bien" set — 7 solid shaft nutdrivers (3/16" thru 3/8" hex openings)

No. 137TB "Tray Bien" set — 5 solid shaft nutdrivers (3/16" thru 3/8" hex openings) and 2 hollow shaft nutdrivers (1/2" and 9/16" hex openings)

No. 147TB "Tray Bien" set — 7 hollow shaft nutdrivers (1/4" thru 1/2" hex openings)

WRITE FOR BULLETIN N666



XCELITE, INC., 10 Bank St., Orchard Park, N. Y. 14127
In Canada contact Charles W. Pointon, Ltd.

Circle 20 on reader's service card

focus voltage were *not* the same. Since both are supplied from a common source (the flyback/horizontal output) any trouble at the source would have dropped both voltages by the same *percentage*. (But not the same *amount*. A 1-kV drop in 5-kV focus voltage would be a loss of 20%; the same 1-kV drop for the 24-kV HV would be a loss of only 4.2%.) The symptoms pointed plainly to trouble only in the focus circuit, which contains only three parts. The focus transformer was easy to clear; the capacitor was okayed by substitution. That left only the focus rectifier, and it *was* bad.

Second case: a Zenith 25CM33 color chassis. Screen, a faintly greenish blur, looking a great deal like the first case. However, when you make close checks, things are a lot different. HV about 24 kV and focus about 4.3 kV. Even though there's "focus trouble," that 4.3 kV seems to be correct, and you'll have to look elsewhere.

Try the brightness control. What— it has no effect at all? Neither does the contrast control? Good clues. If this was a b-w set what would you suspect? Well, it's the same in color—bad picture tube.

First, double-check. The cathodes of the picture tube come down to a three-terminal strip on the back of the chassis, with push-on connectors, for making tracking adjustments. Pull one at a time, and hook an 0-1 milliammeter in series with each. Red gun reads about 100 μ A; blue gun about the same. Green gun about 1.5 mA (that's 1,500 μ A—tsk, tsk). Screen control settings have no effect on this high-current reading.

Now, measure the grid and cathode voltages on the green gun: +275 volts on *both*? Oh-oh, zero bias—this gun is running wide open. The other two grid/cathode combinations show about normal 40-50 volts difference, but the green is running flat-out and its controls have no effect. So, the first diagnosis is confirmed: a short in the green gun. Use a picture-tube tester to confirm it again.

You have nothing to lose, so put the pix-tube tester on REJUV and shoot the tube. You're liable to see gobs of sparks and arcs inside the CRT neck, but you'll probably blow out the short, fixing the tube. Of course, there's no telling how long it's going to last. Oh, well, tell the owner about it and let *him* make the decision. Anyway, it *works* now.

The key clue here was the reaction of the brightness control. This is the same in all CRT's, since it controls the bias. Confirming symptoms were heavy current in the green gun, due to that grid-to-cathode zero-bias condition. You should also pull the tube socket off the CRT base and read socket voltages.

NOW! SAVE OVER \$60 PER YEAR!

JOIN THE NEW PHOTOFACT® OF-THE-MONTH CLUB!

Only \$10 per month brings you 20% more current monthly Photofact service data coverage to boost your daily earnings!



Keep up with current model production—get 6 new Photofact sets every month in handy new file folders sealed in factory carton to insure completeness—easy to file, easy to use. To stay ahead, to save money (individually purchased sets now sell for \$2.50 each)—join the Photofact-of-the-Month Club now!

SEE YOUR SAMS DISTRIBUTOR
OR SEND ORDER FORM BELOW

HOWARD W. SAMS & CO., INC. Dept. REF-12
4300 W. 62nd St., Indianapolis, Ind. 46206

Enroll me in the Photofact-of-the-Month Club. I agree to pay \$10 per month, and understand I will receive 6 current Photofact sets monthly to be delivered by my Sams Distributor (named below).

Name _____

Shop Name _____

Address _____

City _____ State _____ Zip _____

My Sams Distributor is: _____

Signed: _____

Circle 21 on reader's service card

This is another check to make sure that the low voltage isn't due to something like a faulty resistor. The brightness control *did* affect the other two guns, cinching the diagnosis.

This bias voltage, by the way, is the voltage between grid and cathode, *not* between either and ground. One of my little friends said the other day, in a similar situation, "I've got 175 volts of bias on the cathode!"

"No, you haven't!" I said. "You've got 175 volts *to ground*. The only way you can read the bias is to measure between *cathode and grid* on that tube! I don't care if the cathode's 500 volts above ground, that has nothing to do with the grid-to-cathode voltage, which is the only one that has any effect on the tube itself!"

Normal voltages in this Zenith chassis are 275 volts on the cathode and 230 on the grid; the grid is therefore about 45 volts negative with respect to its cathode. This is the bias reading for an average raster; it'll vary with the brightness-control setting. The cutoff bias will vary with the screen-voltage value.

Cathode *currents* are good check-points, too. They will run somewhere in the neighborhood of 100 μ A per gun at normal brightness settings, and all three should be pretty close to the same value. Differences, of course, will be caused by picture content. A reddish scene calls on the red gun for more beam current, hence the red cathode will show more current than the other two. A good many sets use "push-on-clip" terminals, which permit easy current measurement. If the cathode leads are soldered, chances are they'll be on terminals on top of the chassis, relatively accessible.

So, for the quickest diagnosis, look at the symptoms to see what they're trying to tell you. Then, check 'em. If the tests agree with your first diagnosis, well and good. If they don't, make another diagnosis, and start all over again!

Signal generator tracking

I have a problem with an Eico 324 signal generator. The scale is narrower than the band. If I tune in an 1150-kHz station and set the generator to it, then a 560-kHz station reads 535-kHz. I notice this on all bands—J. H., Port Arthur, Texas.

This is a tracking problem. The signal generator wasn't properly aligned when it was built. Try this: Pick up a station on an ordinary radio near the high end of the BC band. Set the generator dial to the exact frequency of the station, and adjust the trimmer capacitor for that range to zero-beat in the radio.

Now, find a station near the low end, set the dial to that frequency, and

Then,
it takes a lot
of know-how to
be a UNIVAC
field engineer?

Want to know
how you can
learn while we're
paying you?



One reason we're leaders in the commercial computer industry is the kind of people we have working for us and the kind of training we give them as they go along.

In the case of our field engineers we give them plenty. So much, in fact, that they don't need a college degree to get started with us. If you have a good grasp of electronic and electro-mechanical fundamentals and a more than ordinary amount of ambition, we'll see to it that you get all the training you can handle on our various computers.... And we'll pay you while in training.

After that you'll be on your way up as one of our career field engineers—installing and maintaining our equipment. We have field offices all across the nation and overseas as well. You'll be assigned to one of them.

Sound good? Wait until you hear about UNIVAC's expense allowances, fringe benefits, and advancement policies.

Interested candidates are invited to write
Mr. J. Corrigan
Manager of Field Administration, UNIVAC
P.O. Box 8100, Philadelphia, Pa.
Dept. 60M

UNIVAC

DIVISION OF SPERRY RAND CORPORATION

An Equal Opportunity Employer

NEW  DLCT 7.5 WATTS	NEW  DLC 7.5 WATTS
NEW  8M2CT 15 WATTS	NEW  8M2C 15 WATTS
NEW  COBREFLEX 30/30T 30 WATTS	NEW  SH-30/30T 30 WATTS

NEW FROM UNIVERSITY SOUND
6
additions to the world's greatest selection of paging-talkback speakers!

What's your pleasure? Communications to fit the whisper of a medium-sized office . . . or the roar of Grand Central Station? University has 'em! Some with full frequency response for background music. All with the crisp, natural voice quality so unique to University. Write for our new '66/'67 PA Catalog today.

UNIVERSITY SOUND
A DIVISION OF ETV LING ALTEC, INC.
Dept. M-69, P.O. Box 1056, Oklahoma City, Okla.
Circle 23 on reader's service card

adjust the coil core for zero beat. Now, go back and recheck the upper end, then back to the low end, and so on. Broadcast stations are accurate to within ± 20 hertz at least, so they make good standards. Check the instructions for calibration, in the book, to be sure you're using the right ones! This generator uses harmonics for the higher bands; so, once you get the lower bands set up correctly, the higher frequencies are automatically correct. To make sure, check them against WWV on a ham or short-wave set at 5, 10, 15 or 20 MHz.

You can get best results by setting the generator for an unmodulated rf output and tuning for zero-beat with the station carrier; ignore the modulation and listen for the zero-beat with the carrier signal; it's not hard to hear.

Replacement for scope's power transformer

I can't find a replacement power transformer for my Precision ES-500A scope. I could use a standard type, but my scope has a tapped low-voltage secondary for the beam-phasing circuit. Any ideas?—W. T., La Mirada, Calif.

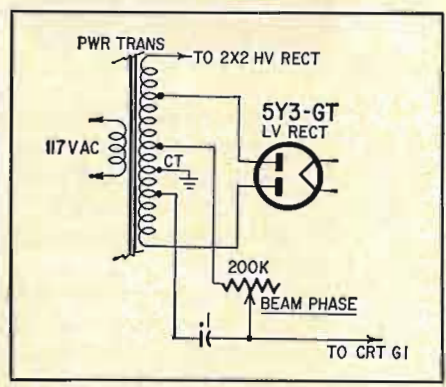

One—and I hope it works! The original circuit shows the taps on the secondary for the beam-phasing signal takeoff (Fig. 1). I don't see why you can't take this voltage off at the ends of the secondary. Cut it down to the right value by adjusting the sizes of the resistors and capacitor in there. After all, this is only a 60-Hz sweep signal, for alignment work. By using a capacitor or capacitors as an ac voltage divider, you can get any voltage you want!

(Note: If it's what I think it is—internal blanking—leave it off: I have one just like this and I never use that!)
END

Radio-Electronics Is Your Magazine!

Tell us what you want to see in it. Your suggestions may make it a better magazine for the rest of the readers as well as yourself. Write to the Editor, RADIO ELECTRONICS, 154 West 14th St., New York, N. Y. 10011.

Let these experts answer your questions on COLOR TV servicing



Color TV Repair

10 servicing experts who write for Radio-Electronics magazine reveal tested techniques, practical ideas, tricks-of-the-trade. Shows how to pinpoint defective color section fast, describes trouble-shooting with a color bar generator, outlines causes of TV failure. Includes servicing of chroma circuits, etc. 160 pages, paperback.
Order #123\$2.95

Servicing Color TV

by Robert G. Middleton. A practical book that shows how to service color TV sets and make money doing it. Includes facts on signal tracing, test equipment, color sync servicing, chroma circuit servicing, matrix testing, etc. 224 pages, paperback.
Order #65\$2.90

TV Sweep Oscillators

by Harry E. Thomas. A practical, non-mathematical handbook that explains relaxation oscillators, pulse techniques, transistorized oscillators, sawtooth generators, synchronization, failure analysis, sweep oscillator servicing, etc. 226 pages, paperback.
Order #119 (at parts jobbers only)\$3.95

Horizontal Sweep Servicing Handbook

by Jack Darr. Gives you fast, simple methods of locating and repairing troubles in the sweep system. Practical shortcuts, developed on the bench for rapid isolation of trouble. Includes horizontal oscillator, multivibrator, output stage, etc. 224 pages, paperback.
Order #115\$4.10

Order from your Electronic Parts Distributor today, or mail to:
Gernsback Library, Inc., Dept. RE-1266,
154 West 14 Street, New York, N. Y. 10011

Send the following books:

- #123 (\$2.95)
- #65 (\$2.90)
- #115 (\$4.10)

I enclose \$..... (prices 10% higher in Canada)

Name

Address

City State Zip

My distributor is

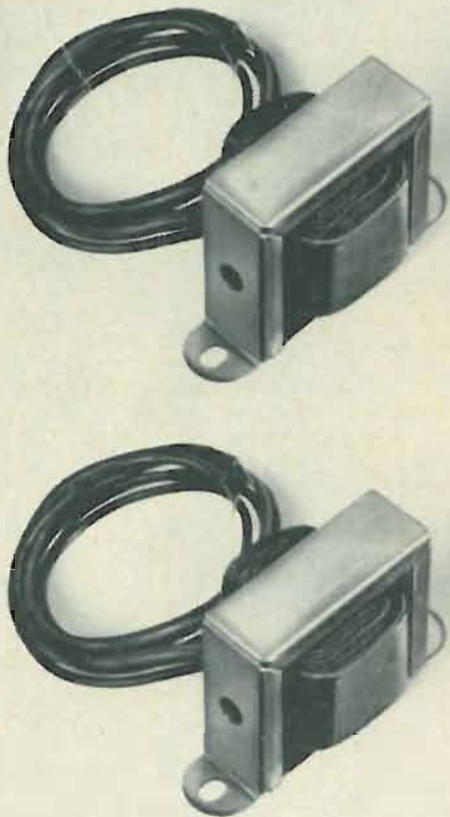

**Insist on Genuine RCA
Replacement Parts...**

the only look-alikes that perform alike

and help eliminate costly call-backs.

Only genuine RCA replacement parts assure the quality performance originally engineered into RCA equipment. Every material, every electrical value, every mechanical tolerance—all have been precisely balanced to deliver 100% of the performance RCA specified in the original part. Good reasons why genuine RCA parts prevent the costly call-backs you gamble on when using substitutes.

Want extra proof of the high performance standards you get in genuine RCA parts? See how those RCA parts with universal application upgrade performance wherever you use them.

Your RCA Distributor can supply you with all the genuine RCA replacement parts you need, competitively priced—and readily available. Call him. And while you're ordering, ask for cross-reference and application literature on RCA replacement parts.

RCA PARTS AND ACCESSORIES, DEPTFORD, NEW JERSEY



The Most Trusted Name in Electronics

Genuine RCA replacement parts are available for all these categories of equipment. Color TV, Black and White TV, Radios, Hi-Fi's, Tape Recorders, Electronic Language Laboratories, Broadcast transmitting, Radiomarine, Microwave Communications, Mobile Communications, Servicemen's Test Equipment, Citizens' Band Transceivers, and Scientific Instruments.

The "Chip"

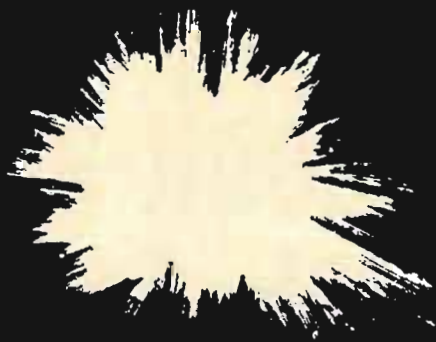

**...will it make or break
your job future?**

THE DEVELOPMENT OF INTEGRATED CIRCUITRY is the dawn of a new age of electronic miracles. It means that many of today's job skills soon will be no longer needed. At the same time it opens the door to thousands of exciting new job opportunities for technicians solidly grounded in electronics fundamentals. Read on the facing page what you need to know to cash in on the gigantic coming boom, and how you can learn it right at home.

TINY ELECTRONIC "CHIPS," each no bigger than the head of a pin, are bringing about a fantastic new Industrial Revolution. The time is near at hand when "chips" may save your life, balance your checkbook, and land a man on the moon.

Chips may also put you out of a job ... or into a better one.

"One thing is certain," said *The New York Times* recently. Chips "will unalterably change our lives and the lives of our children probably far beyond recognition!"

A single chip or miniature integrated circuit can perform the function of 20 transistors, 18 resistors, and 2 capacitors. Yet it is so small that a thimbleful can hold enough circuitry for a dozen computers or a thousand radios.

Miniature Miracles of Today and Tomorrow

Already, as a result, a two-way radio can now be fitted inside a signet ring. A complete hearing aid can be worn entirely inside the ear. There is a new desk-top computer, no bigger than a typewriter yet capable of 166,000 operations per second. And it is almost possible to put the entire circuitry of a color television set inside a man's wrist-watch case.

And this is only the beginning!

Soon kitchen computers may keep the housewife's refrigerator stocked, her menus planned, and her calories counted. Her vacuum cleaner may creep out at night and vacuum the floor all by itself.

Money may become obsolete. Instead you will simply carry an electronic charge account card. Your employer will credit your account after each week's work and merchants will charge each of your purchases against it.

When your telephone rings and nobody's home, your call will automatically be switched to the phone where you can be reached.

Doctors will be able to examine you internally by watching a TV screen while a pill-size camera passes through your digestive tract.

New Opportunities for Trained Men

What does all this mean to someone working in electronics who never went beyond high school? It means the opportunity of a lifetime—if you take advantage of it.

It's true that the "chip" may make a lot of manual skills no longer necessary.

But at the same time the booming sales of articles and equipment using integrated circuitry has created a tremendous demand for trained electronics personnel to help design, manufacture, test, operate, and service all these marvels.

There simply aren't enough college-trained engineers to go around. So men with a high school education who have mastered the fundamentals of electronics theory are being begged to accept really interesting, high-pay jobs as engineering aides, junior engineers, and field engineers.

How To Get The Training You Need

You can get the up-to-date training in electronics fundamentals that you need through a carefully chosen home study course. In fact, some authorities feel that a home study course is the best way. "By its very nature," stated one electronics publication recently, "home study develops your ability to analyze and extract information as well as to strengthen your sense of responsibility and initiative." These are qualities every employer is always looking for.

If you do decide to advance your career through spare-time study at home, it makes sense to pick an electronics school that specializes in the home study method. Electronics is complicated enough without trying to learn it from texts and lessons that were designed for the classroom instead of correspondence training.

The Cleveland Institute of Electronics has everything you're looking for. We teach only Electronics—no other subjects. And our courses are designed especially for home study. We have spent over 30 years perfecting techniques that make learning Electronics at home easy, even for those who previously had trouble studying.

Your instructor gives your assignments his undivided personal attention—it's like being the only student in his "class." He not only grades your work, he analyzes it. And he mails back his corrections and comments the same day he gets your lessons, so you read his notations while everything is still fresh in your mind.

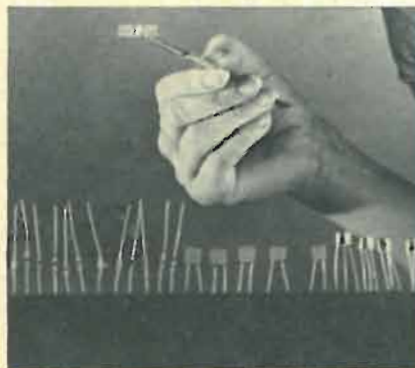

50 FUNCTIONS IN A SINGLE CHIP. The functions of these 50 separate transistors, diodes, resistors and capacitors can now be formed by the tiny dot in the center of the integrated circuit held by the tweezers.

Always Up-To-Date

Because of rapid developments in electronics, CIE courses are constantly being revised. Students receive the most recent revised material as they progress through their course. This year, for example, CIE students are receiving exclusive up-to-the-minute lessons in Microminiaturization, Logical Troubleshooting, Laser Theory and Application, Single Sideband Techniques, Pulse Theory and Application, and Boolean

Algebra. For this reason CIE courses are invaluable not only to newcomers in Electronics but also for "old timers" who need a refresher course in current developments.

Praised by Students Who've Compared

Students who have taken other courses often comment on how much more they



TINY TV CAMERA for space and military use is one of the miracles of integrated circuitry. This one weighs 27 ounces, uses a one-inch vidicon camera tube, and requires only four watts of power.

learn from CIE. Mark E. Newland of Santa Maria, California, recently wrote: "Of 11 different correspondence courses I've taken, CIE's was the best prepared, most interesting, and easiest to understand. I passed my 1st Class FCC exam after completing my course, and have increased my earnings \$120 a month."

Get FCC License or Money Back

No matter what kind of job you want in Electronics, you ought to have your FCC Commercial License. It's accepted everywhere as proof of your education in Electronics. And no wonder—the Government licensing exam is tough. So tough, in fact, that without CIE training, two out of every three men who take the exam fail.

But better than 9 out of every 10 CIE-trained men who take the exam pass... on their very first try!

This has made it possible to back our FCC License courses with this famous Warranty: you *must* pass your FCC exam upon completion of the course or your tuition is refunded in full.

Mail Card For Two Free Books

Want to know more? The postpaid reply card bound in here will bring you free copies of our school catalog describing today's opportunities in electronics, our teaching methods, and our courses, together with our special booklet on how to get a commercial FCC License. If card has been removed, just send us your name and address.

ENROLL UNDER NEW G.I. BILL

All CIE courses are available under the new G.I. Bill. If you served on active duty since January 31, 1955, OR are in service now, check box on reply card for G.I. Bill information.

CIE

Cleveland Institute of Electronics

1776 E. 17th St., Dept. RE-27 Cleveland, Ohio 44114

Accredited Member National Home Study Council • A Leader in Electronics Training... Since 1934

NEW TWIST IN ACCURATE AUTOMOTIVE ANALYSIS

A new era of using electronic instruments for diagnosis in automobile servicing may open many opportunities **By ALLEN B. SMITH**

IF A HANDFUL OF PROGRESSIVE AUTO-service corporations have analyzed their future correctly, a whole new phase of electronic servicing and instrument sales lies just around the corner. Electrical and electronic devices have been used for years by auto-service technicians, particularly in ignition analysis. But new and exciting is the concept of a diagnostic center using electronic instruments to make 100 or more individual tests on each car to check its performance.

More than 125 such automotive clinics are now in operation throughout the country, most of them operated or sponsored by major auto-service companies. While there are several variations on the main theme, the basic idea is to provide quick and accurate evaluation of a car's performance, mechanical condition and general road-safety conformity. Each owner whose car is examined in such a center can be sure whether or not his mount measures up to modern standards.

Instrumentation in a typical diagnostic center usually includes a chassis dynamometer, brake analyzer, headlight tester, exhaust analyzer, a system to evaluate front-end alignment and steering geometry, ignition oscilloscope and a variety of single-purpose testers. With each major unit performing several individual tasks, as many as 75 to 125 separate checks may often be made on each car.

The role of the personnel using the equipment is as specialized as the in-

struments themselves. The technicians—"diagnosticians" in industry lingo—observe and record, then analyze the results of their examination.

This doesn't mean these men are untrained or selected at random. Quite the contrary. Each sponsoring company selects its diagnosticians carefully and schools them intensively in the operation of each instrument or system and in the overall function of the clinic. Automotive knowledge must be combined with a basic understanding of the part electronics plays in automotive diagnosis. The diagnostician must correlate the analysis information to the condition of the car. He discusses his conclusions with the customer, who must then decide which repairs will be made and who will make them.

Each service center includes comprehensive repair facilities, of course, but the customer is under no obligation to have repairs done there. He pays his money—under \$10 in most centers—and receives a report on his car's condition every bit as thorough as the physical examination he'd receive from his physician.

A typical center

The first of this new generation of automotive clinics was established on an experimental basis by the Mobil Oil Co. in 1962 at Cherry Hill, N. J. The company now operates four additional centers—West Covina, Calif. (near Los Angeles); East Meadow, Long Island, New York; Glendale, Wis. (near Mil-

waukee), and Dallas, Tex.—all nearly identical to the first.

These centers are divided into two primary areas—a 62-foot drive-through lane where diagnosticians evaluate the condition of the car, and a repair area similar to that of a major automobile dealer. There also is an air-conditioned waiting room where the customer may watch his car's examination, and a private conference booth where he receives the report of the diagnosis.

The electronic instruments in the diagnostic lane have normal-size meters and indicators for viewing by the diagnostician. On the wall opposite the waiting room, huge duplicate meters help the car owner see the entire operation. He also may listen to a recorded description of each phase of the diagnosis, through telephone-type handsets. The recorded commentary is keyed to the progress of the car through the lane by the same stepped-relay-and-micro-switch system that automatically activates each diagnostic instrument as the car travels its 62-foot road to better health.

The instruments

The chassis dynamometer and its associated metering circuits tell about road speed, road horsepower, brake force, brake balance and dynamic wheel balance. The dynamometer is a hydraulic load-absorbing device used to measure and indicate the power applied to the road surface (simulated by the dynamometer) by the rear wheels. Large double rollers cradle each rear wheel and are driven by the wheels in the first mode of operation.

Each pair of double rollers also can be driven independently by powerful motors to rotate the car's front or rear wheels at simulated road speeds under full chassis loads. In this mode, braking force and balance are checked by a sensing device that detects the braking effort of each wheel as it opposes the driving force applied through the rollers. Dynamic wheel balance also is determined by a beam-illuminated photocell that senses any displacement of the driving rollers due to vibrational imbalances.

Front-end alignment and steering

geometry are checked on a separate machine, using a pair of motor-driven double rollers—similar to those of the chassis dynamometer—to rotate each front wheel at road speeds. Each pair of rollers is cradled in a floor-level table assembly which can move on its vertical, horizontal and longitudinal axes, thus permitting it to align itself perpendicular to the plane of rotation of each wheel. Delicate sensors measure the angular displacement of the table in its various axes and show the angles of toe-in, camber and caster on individual meters. A single meter indicates for the

customer the degree of tire scrub.

Automatic transmissions are analyzed with a direct-writing oscillographic strip recorder. During open-throttle acceleration tests made while the car is on the dynamometer, the oscillograph plots engine speed vs a fixed time base. Shift points and ratio-change characteristics are recorded on the strip chart, evaluated by visual observation and compared with exact specifications for each type of transmission. Since these tests are made under simulated full-load road conditions, the entire power train also can be evaluated for mechan-

Electronics-equipped diagnostic center has several banks of meters and indicators grouped according to function.

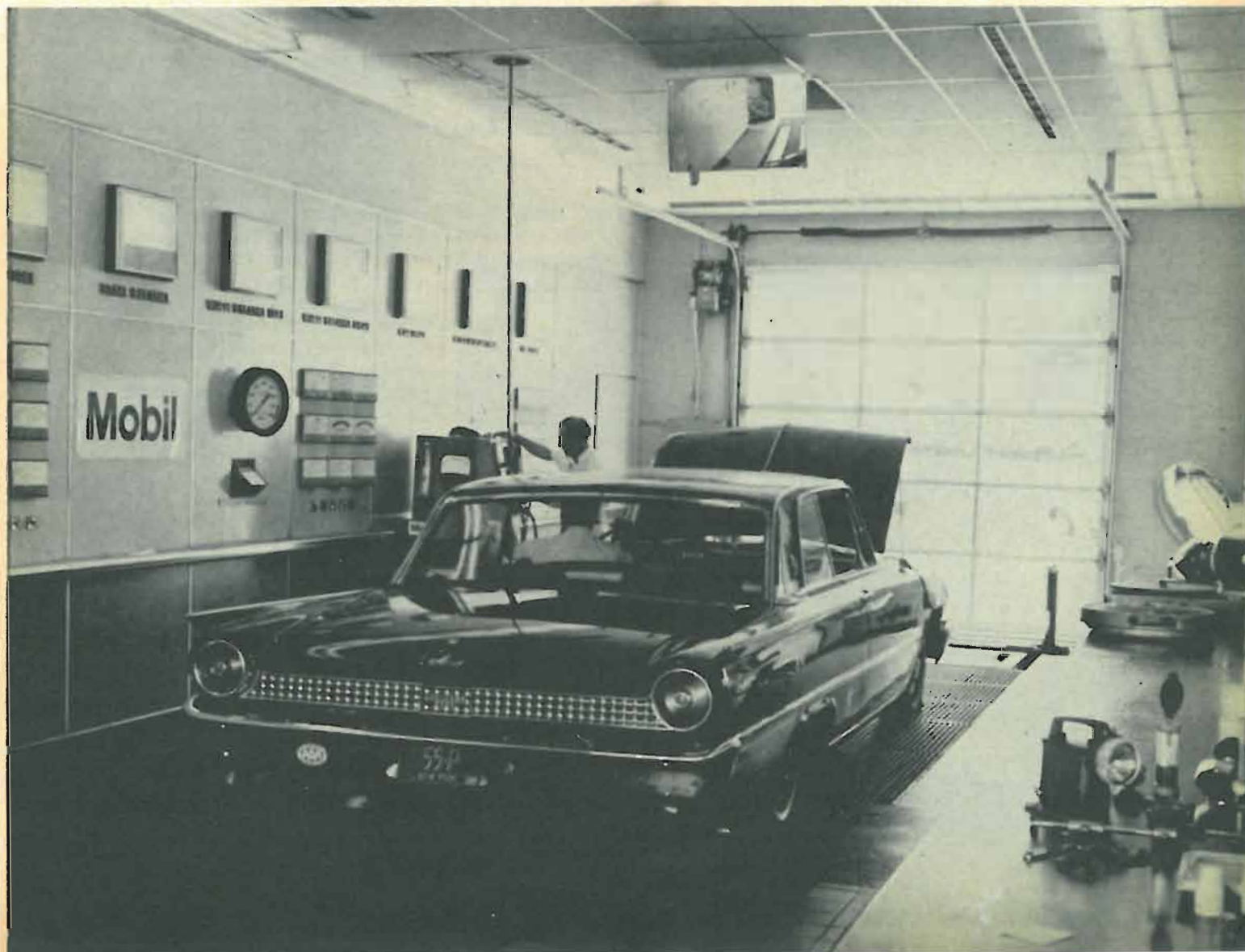

ical defects as well as for performance.

The electronic "heart" of the diagnostic center is the ignition oscilloscope and its companion console instruments. Using this group of instruments, the diagnostician can interpret malfunctions in sparkplug firing, point operation, condenser discharge characteristics (the auto-service industry has not yet adopted the term "capacitor"), distributor cam and rotor action, coil performance and the wiring harness. Individual testers are used to check the spark advance, ignition timing, combustion efficiency, system voltages under static and dynamic conditions, manifold pressure, and fuel pressure and flow rate.

This group of instruments surrounding the ignition scope represents the best opportunity for electronics technicians who want to service automotive test equipment. Much of the circuitry is unfamiliar to automotive electricians who service most of the other equipment, and they would rather leave it alone.

Others in diagnostics

Several other major American corporations also have embarked on extensive programs of clinic operation. The Ford Motor Co., for example, opened the first of a series of nationwide centers last June at St. Louis, Mo. This pilot center is operated by one of the company's major dealer organizations. Ford plans to have 50 such installations in operation by the end of the year.

Other activity: Enco, Div. of Humble Refining Co., already has 8 to 10 centers operating in each of several major cities. Goodyear Tire Co. has 2 centers in Akron, Ohio, and plans several more. Shell Oil Co.'s Detroit-based *Motorlab* is the prototype center for 20 others planned for the near future, and Pure Oil Co., with a major installation in Norfolk, Va., also plans a nationwide network of centers.

Independent operators, most of whom are automobile dealers in cities of medium to high population density, also have hopped aboard the bandwagon.

on. Their facilities range from those servicing as few as 8 cars a day to others capable of handling 1000 cars a month.

To find out how this dynamic development in automotive servicing can affect the electronics repair technician, we spoke with Paul Strycker, owner and manager of Test Equipment, Inc., Milwaukee, Wis. TEI is a sales, service and training organization started in 1962 as a part-time repair business in Strycker's basement. Since September 1965, it has been a full-time and growing enterprise. As a factory-authorized repair depot for several leading manufacturers of automotive test equipment, TEI services equipment ranging from battery chargers and voltmeters to complex ignition analyzers. Warranty repairs for equipment sold in a three-state area pass through this service shop.

As Strycker explains his start in business, "I sorta came in through the side door." A friend who sold some of the equipment often complained he couldn't find anyone to service it. "I didn't really know much about the specific equipment," says Strycker, "but I figured—with my electronics background—I could follow the electrons in one end and out the other." He began servicing occasional scopes in his basement shop, on a part-time basis, in addition to his regular work as electronics specialist for a firm of engineering consultants. After 3 years of sustained growth, Strycker made the plunge into his new venture as a full-time businessman.

For his first full year of operation, he figures he just about has broken even financially—something hard to do, according to the Small Business Administration. Optimistic about the future both of his own venture and of diagnostic centers, Strycker employs a salesman and a full-time service technician and divides his own time between sales, bench work and training sessions. Repair charges, always difficult to establish, have been worked out using a combination of manufacturer-suggested flat rates and experience.

According to Strycker, the equipment isn't difficult to service, provided the technician has a sound understanding of basic circuit operation and elec-

Automotive electronics specialist Paul Strycker completes final checkout of scope-type ignition analyzer. Unit is used, but seldom repaired, by auto mechanics.



tronic theory. He also must know how the equipment relates to the automobile and its accessories. Some specialized instruments require a way to simulate the signals that would be generated by an automobile during normal operation and analysis. Test sets for this purpose are available from manufacturers of the basic equipment. These "tester testers" would be important to any technician or shop specializing in automotive test gear.

We also visited a factory-operated sales/service branch of Sun Electric Corp., Chicago, Ill., one of the largest manufacturers of automotive test equipment. Sun has 30 similar sales, service and training branches throughout the United States, all directly affiliated with and under the sole direction of the parent company. Part of an extensive direct-sales organization, each branch functions as an extension of the main plant.

The branch in New Berlin, Wis., a western suburb of Milwaukee, serves Wisconsin and part of upper Michigan. As one of the larger branches, its shop is headquarters for eight field representatives, each servicing a specific territory on a resident basis. Units that can't be repaired in the field are shipped to the branch by truck or commercial parcel service, repaired and returned within 48 hours. A completely equipped shop, headed by branch service manager Carl Steffen, can handle repairs from simple component replacement to major overhaul of complete console-combination units. Both Steffen and his assistant, Dick Engel, have a lot of experience in automotive diagnosis using electronic analyzers and in electronics theory and practice. Steffen feels a technician needs a knowledge of both areas to make the best use of his time at the bench.

Experience in automotive theory and in the practical operation of automotive testing equipment is easy to obtain in many areas, because manufacturers and authorized service centers hold regular classes in the two phases of analysis. A telephone call to the representative of any major equipment company should provide all necessary information on classroom schedules and cost. These classes generally are open to anyone, and the opportunity of adding

automotive theory to a good electronics background is an obvious advantage to anyone interested in the field.

Sun branch manager Rollie Baerenwald emphasized for us that his company is constantly searching for well-qualified service personnel. While many of the technicians working in branch offices have years of experience in aspects unique to automotive gear, a sharp TV or radio service technician can make a relatively painless transition.

The future

In little more than 3 years, the diagnostic center has become one of the hottest concepts in automotive merchandising. Stanford Research Labs, associated with Stanford University, in a recently published report predicts there will be 15,000 major installations by 1975, and as many as 150,000 smaller centers perhaps specializing in one or two phases of testing and analysis.

Manufacturers are investing large

sums in developing even more sophisticated analyzers. Allen Electric & Equipment Co., for example, soon will begin delivering a computer-type analyzer which performs 41 separate checks programmed from prepunched reference cards for each make and model of car. The analyzer is a comparator which checks each measured parameter against the punched-card specification chart, providing digital readout of each result. It also presents the customer with a running printout of each test result. Employing integrated circuits and microelectronic modules, the unit represents another servicing opportunity for skilled technicians.

With Americans scheduled to spend an estimated \$21 billion in 1966 for auto repairs (labor and parts), the diagnostic-center revolution seems likely to attract much of the ever-expanding annual expenditure for auto maintenance. It may become a sizable segment of the electronics servicing industry as well.

END

Recorded commentary describes each step of the diagnosis as it is performed, as customers follow technician's measurements on large remote-reading meter scales.



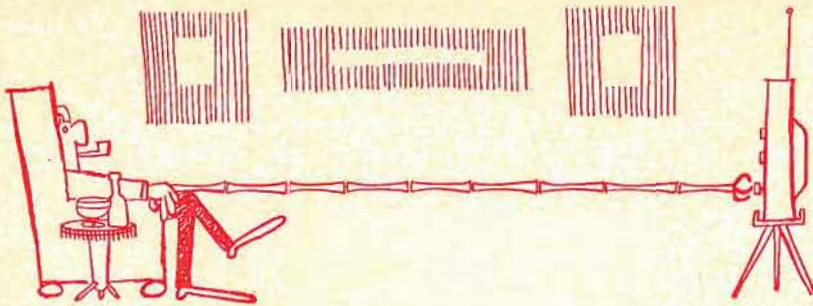

Who's Afraid of the "Magic Wand?"

Using a fearless approach and cold logic, the supersonic idiosyncrasies of TV remote-control are quietly laid to rest **By FRANK SALERNO**

WHEN THE ELECTRICAL ENGINEERS WHO designed the various types of remote-control units several years ago had finished their task, they found they had created something of a mystery. In delving into the area of ultrasonic frequencies—and supported by the "magic tuning" approach used by the boys in advertising's back rooms—the slide-rule clan spawned a device the mere mention of which put most TV service technicians into a tailspin.

For many years a relatively simple little bit of circuitry has consequently been viewed with such wide-ranging at-

titudes as fear, apprehension and total disregard. The set owner, too, has responded in somewhat the same manner. If the pushbutton hand control works, fine; if not, well, so what? The set could always be tuned by hand, anyhow. Since remote-control magic wands most often were part of large, floor-model console or combination TV's, the owners could see scant reason to have everything carted to the shop for a questionably needed repair. As a result, nonfunctioning and dusty little black boxes literally littered the living rooms of viewers from Albuquerque to Ashtabula.

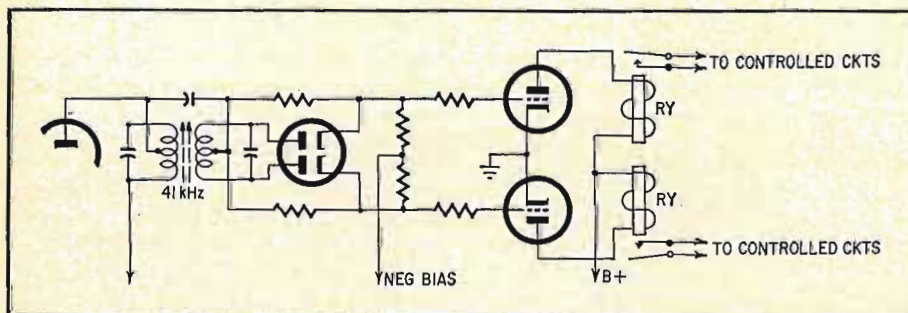

Fig. 1—Although this is a simplified circuit, it's perfectly clear that the receiver section holds no surprises for the average service technician. After all, this hookup has been used for years as the sound discriminator in FM and television receivers.

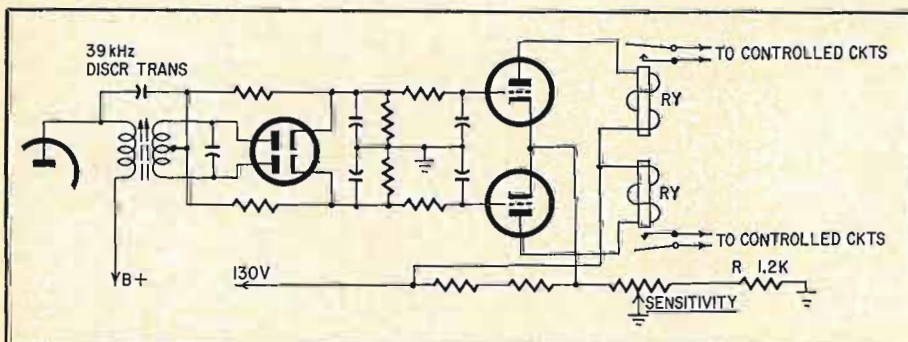

Fig. 2—A positive voltage applied to the cathodes of the relay tubes establishes operating bias. The range of the sensitivity control may be altered by changing the value of R. Too much bias voltage can prevent proper operation of the relays.

Times, however, have changed. The era of the portable TV is here, and so is the integrated remote-control chassis. Customers regard a remote-control capability much more highly today, and so must the service technician. Being portable, the newer sets lend themselves more easily to shop work, so the customers no longer are reluctant to let the set out for repair.

A brief circuit description

The heart of the remote receiver is the relay tube—usually a triode with its grid biased well below cutoff and its plate fed in series with a relay coil. When the transmitter key is depressed, a signal is generated that removes the bias from the relay tube and sends it into conduction. When this happens, the relay coil energizes the solenoid and closes the relay switch. The switch in turn performs its functions: change channels, turn the set on and off, mute the sound channel, etc. There is a separate relay tube and coil for each function, but each operates in exactly the same way. When the transmitter is activated, it sends out a signal which is picked up by the receiver transducer (microphone), and amplified, and used to activate the relay tube.

Obviously, multifunctional remote-control units require a variety of control-signal frequencies, a fact more easily understood by examining a typical example. If the remote unit is required to initiate four functions—change channels up, change channels down, turn set on and off and mute sound, for example—each function is assigned a different frequency. Common frequencies are 42, 40, 39 and 37 kHz.

The receiver transducer and its amplifiers are designed to pass all four frequencies equally well. Following these two straightforward circuits are two separate discriminator circuits, one tuned to 41 kHz (center of 42 kHz and 40 kHz), and the other tuned to 38 kHz (center of 39 kHz and 37 kHz).

A discriminator—remember your FM theory?—is a frequency-sensitive circuit that uses tuned circuits and two diodes. When the incoming signal is higher in frequency than that for which the discriminator is tuned, one diode conducts; when lower, the second diode conducts.

This frequency-selective characteristic sheds a little light on how remote-control receivers work. Whenever the transmitter is keyed, generating any one of the four assigned frequencies, one of the diodes will conduct because of the receiver's discriminator action. The conducting diode develops a positive voltage on its cathode, offsetting the bias voltage on the associated relay tube—see Fig. 1. All remote receivers are pretty standard. Some may use tubes, others transistors.

Frequencies used may vary from unit to unit. The sequence of events outlined above, however, is always the same.

Hand transmitters also vary somewhat in detail. Some work mechanically, striking metal bars with spring-loaded hammers to generate the sonic signal. Others are compact transistorized audio generators that radiate their signals. Still others employ a spring-loaded piston to push air through tiny holes, thus generating ultrasonic tones.

Actual troubleshooting cases

In spite of their basic design simplicity and straightforward operation, remotes still have their share of oddball troubles. As usual, though, it takes only a couple of victories to reassure the typical TV technician. To illustrate: A customer brought a Du Mont portable to the shop recently. The remote unit was erratic. When it worked, it did so only from a 3- or 4-foot distance. This set happened to require only a simple repair, but it could easily have been a real dog if a seemingly insignificant clue had been overlooked during the initial inspection.

After some preliminary checks that failed to reveal anything important, I began disconnecting the remote section from the main chassis prior to some intensive detective work. While disconnecting the transducer cable, I saw an excess of solder flux inside the plug pin, so mostly out of habit I cleaned and resoldered it. Much to my surprise, when I reconnected the cable the operating range of the unit had increased to well over 20 feet—and it worked every time! Apparently the energy from the transducer simply was not reaching the first amplifier because of the poor solder connection.

The most important voltage in a remote receiver is that found on the relay-tube grids. This is the negative voltage that keeps the tube cut off. A voltage reading taken at the grid will show what happens as the transmitter key is hit. On a normally operating set, this voltage will make a healthy positive swing. As it approaches zero, the tube will jump suddenly into conduction and the relay will operate. If a bad relay is suspected, the bias voltage can be shorted momentarily. No action—bad relay.

If the bias voltage moves only feebly, the first step should be to check operating voltages throughout the amplifier. Check filter capacitors, resistors; anything reducing the gain through the system could be at fault.

A Motorola 19T5 was another reduced-sensitivity problem. With the sensitivity control advanced to maximum, the set failed to operate over the required distance. When all components checked okay, the alignment or

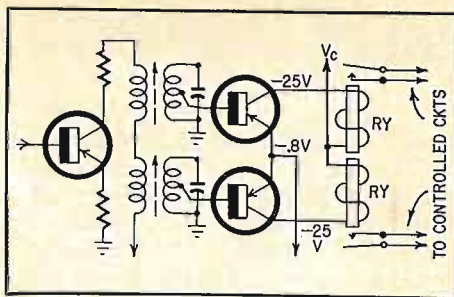

Fig. 3—Transistorized version has series of tuned circuits, one for each remote mode, otherwise similar to tubed units.

tuning of the receiver discriminator seemed a good candidate for attention. I clipped a meter to the relay-tube grid and adjusted the transformer slugs an eighth of a turn at a time, always aiming for the maximum possible voltage reading when the transmitter was keyed. Exercise caution here, though—peaking one frequency may attenuate another.

In this case, I gained everything possible from careful realignment, but the range was still inadequate. After fussing over it for the better part of a day, I finally decided to play junior engineer and experiment a bit.

On this particular chassis, the sensitivity control sets up the operating bias of the relay tubes (Fig. 2). At maximum range (minimum bias) setting, bias voltage read 6.5 negative. At close range this voltage was easily overcome by the discriminator swing when the transmitter was keyed. As I moved away from the set, the swing lessened, and the relay tubes failed to kick into conduction.

I was certain that the receiver was perfect in every respect but felt that a bias level of 6.5 volts was a little too much for the discriminator to overcome. I added another 1,200-ohm resistor across R, which gave me the necessary drop. With a more useful sensitivity-control range, the bias level was set to -5 volts (grid-to-cathode) which gave full use of the remote control in all modes.

The dog that really turned my graying hair grayer was a Magnavox MV411M, suffering from intermittent operation in the channel-change mode. While going through the tubes, keying the transmitter each time a tube was changed, I found one fact becoming apparent. The distance between the set and remote-unit transmitter was less critical than how hard the keying button was pressed. If the key was pressed down gently, the relay would seldom, if ever, close; if pressed quickly, the relay would close more often than not.

Opening the transmitter case to investigate, I found the unit worked on the air principle mentioned previously.

As the key was pressed, a small bellows forced a jet of air through a tiny pin-hole, generating an ultrasonic whistle. I keyed the unit a few times to check its operation and noticed a tiny speck of dirt dancing around inside the hole. I drew the speck out with a pin, tried again, and the control worked perfectly every time.

Solid-state remote units

Since transistorized circuitry is on the rise, let's take time to check a typical solid-state unit. In principle, the transistorized remote chassis is similar to the tube-type chassis. The signal received by the transducer is passed through several stages of amplification, then applied to the driver stage. Instead of using discriminator circuits, however, the transistorized version generally uses separate tuned-tank circuits in the base of each relay transistor (Fig. 3). As each of the several signal frequencies comes out of the driver stage, it passes through the string of tank circuits until it reaches the one tuned to that particular frequency and develops a signal voltage at the base of the associated relay transistor. The transistor conducts, sending current through the relay coil, thus closing the relay switch.

Here, collector voltage (V_c) provides the key troubleshooting symptom. It reads full B- voltage while the transistor is cut off. As the transistor kicks into conduction, V_c will swing sharply positive.

A Zenith Space Command portable reached the shop with a bad case of reduced sensitivity. Collector voltages read a proper -25 and swung to about -5 when the transmitter was keyed. The system obviously was working, but experience with these units had taught me to expect even greater swings than that for top performance. All components that might reduce amplifier gain were checked, but nothing turned up!

With a meter clipped onto the channel-changing collector, I turned its base-coil slug an eighth of a turn and keyed the transmitter. The relay clicked as the pointer shot past zero. I stepped back 10 feet and hit it again—shot past zero again. After touching up the muting-mode tuned circuit, I found the remote transmitter would operate the relays even through a wall!

Voila! The mystery in remote-control units has disappeared with mighty little fuss or bother. Granted, they'll give your peace of mind a jolt or two, but isn't that true of all electronics servicing? Besides, it would be a pretty dull way to make a living if we didn't have to hustle to keep up with equipment improvements and increasingly advanced techniques. That's probably why we chose this business in the first place! END

WESCON and the Future Engineers

By **FOREST H. BELT**

WE FLEW OUT TO LOS ANGELES FOR WESCON (Western Electronic Show and Convention), and spent a full day figuring out what was most important to tell you about. Viewed from the amphitheater bleachers of the huge Sports Arena, the exhibit floor looked somewhat like a large carnival. The lighting was multicolored, spectacular and bright. Activity was thick almost constantly.

Later, walking among the exhibits, I couldn't shake the feeling of circus. Besides the inevitable attractive and ornamental girls brightening up certain display spaces, some companies had professional pitchmen demonstrating this or that electronic contrivance. With crowds gathered in the aisles around the demonstrations that sounded most interesting, the display hall seemed for all the world like a midway.

Nevertheless, a lot of serious business went on at WESCON this year. Besides technical sessions at which engineers from all over the country were briefed on the newest state-of-art developments, at conferences all over the place engineers talked with representatives of key companies about electronic

applications and development problems.

The show was primarily industrial. The few displays that concentrated directly on consumer electronics were conspicuous by their scarcity. Solid-state was king, as you'd probably expect. But this year's exhibit showed more integrated-circuit devices than I've seen before at a single show. And the prices are coming down.

Though IC's were all over the place, not many of them were the low-cost linear or analog devices needed for consumer and entertainment electronics. The linears displayed were for the most part expensive types—\$30 and up.

The low-cost ones we did see, however, mean that home entertainment will lean heavily on IC devices soon. Techniques are rapidly being developed to put digital-logic IC's to work in pseudo-analog applications. These developments hasten the time when home-electronic appliances, radios, amplifiers, etc., will be made up of IC's exclusively.

Back in a corner of the exhibit hall, easily overlooked by anyone but a determined browser, and receiving far too little (in my opinion) publicity and fanfare, was a tiny "subhall" devoted to the

Future Engineers Show. Here in 32 booths a group of high school students displayed engineering projects they had developed as part of their science training. Most of the projects were either original or contained original development as part of the project.

I found myself very enthusiastic over some of the projects. All of them were in some way related to electronics, but sometimes only indirectly. For example, one related to wind-tunnel effects and another to nuclear physics; electronic equipment was used in both experiments to evaluate results.

The only girl in the group, Margaret Fitzsimmons of St. Francis Xavier School in Phoenix, Ariz., built an exhibit showing logical operations with a "nim" computer. The computer plays the game only to win; you simply can't beat it.

Two projects attracted my interest more than the rest, because of the present emphasis on automotive safety. As I suggested in a recent editorial (RADIO-ELECTRONICS, August 1966, page 2), the auto industry can join hands most effectively with the electronics industry to solve many problems of auto safety. These two projects demonstrate well the aptness of this assumption.

An electronic braking system, activated by radar, was described in the project of Louis D. Bell of Arcadia High School in Phoenix, Ariz. Louis hadn't finished a working model, but is planning to install his system on a full-size car. The radar scans either backward or forward, depending on the direction the car is traveling. Sensing an obstacle, the radar triggers the automatic braking system designed by Louis. The braking system is ingeniously planned to apply just the amount of braking that suits the stopping situation, whether emergency or merely corrective.

The other auto-safety project, an automatic steering system designed for eventual freeway use but presently installed in a plastic model, was developed by a 17-year-old high school senior from Alhambra, Calif. When I talked with him and examined his project symposium notebook, I found it so well written that I thought he should write an article on his project for RADIO-ELECTRONICS readers. Steve (Faulstich) did just that. The story begins on the following page. Not only does it tell how his automatic steering system works, but explains how you can build one of your own into a model automobile.

Sponsored jointly by WESCON and the IEEE, the Future Engineers program is small but exceptionally constructive in building future engineers and scientists. To me, the Future Engineers Show was one of the highlights of WESCON. **END**



One of the eye-catching displays at the booth for "future engineers" was Steven Faulstich's automatic steering system.



Young Masaaki Yamato shows his ion-propulsion system supporting a wire screen. Machine can lift several ounces.



The only girl "future engineer," Margaret Fitzsimmons, built this computer that regularly beats her at the game of "nim."

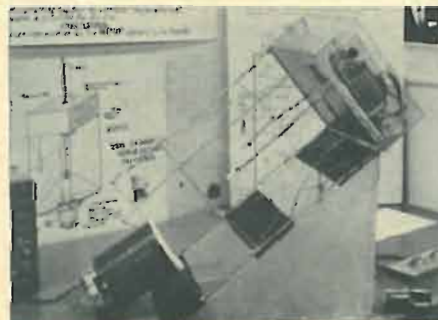

Looking like baling wire and chewing gum, OCMOP is an undersea research device, less costly than most subsea capsules.

AN ELECTRONIC SYSTEM TO GUIDE TOMORROW'S CARS

This miniature system employs principles that can be used to lock the steering of a full-size car to the road

By STEVEN FAULSTICH

SOMEDAY SOON, AUTO COMMUTERS MAY drive onto the freeway, radio their destination to a central controlling computer, then sit back while electronic circuits drive their cars to the correct exit ramp. Telemetering equipment in each car and at the central station could control speed and braking. Such equipment could make the country's freeways safe and efficient, provided there is a system to keep the cars in their lanes—an automatic steering system.

A working model of such a steering system is an interesting project to build, and the finished car is an attention-getter at science fairs or simply fun to experiment with. There's no doubt it's a conversation piece, with today's emphasis on auto safety. What follows is one method of constructing such a model, but much of the design is flexible, so use your imagination.

The model car in this system follows a single-wire transmitting antenna laid down the middle of the lane. Two receivers under the car (one next to each front wheel) pick up the weak signal from a small AM transmitter, detect its audio tone, and rectify this tone to a dc bias voltage.

When a receiver is near enough to the wire, its output signal (and bias) becomes large enough to cause a servo-control transistor to conduct. When the car is centered over the transmitting antenna, bias from neither the right nor the left receiver is enough to activate the transistor. As the car drifts to the right side of the road, signal output from the left receiver goes up because the receiver is closer to the transmitter wire. This small sideways movement of the car can thus boost the bias on the transistor enough to cause it to conduct through its load, which in this case is a small dc motor connected to the steering linkage of the model.

This little servo motor turns the front wheels to the left until the car is again centered over the antenna. When the bias signal disappears, the wheels automatically return to face straight ahead, and the car continues along until it again moves slightly to one side.

If the right receiver gets close enough to the center-lane wire, the little servo motor will be turned on in the opposite direction, and then the car will again center itself. Get the idea?

Commercially available units are used in this model. The transmitter is a low-power AM broadcaster modulated with a one-transistor code-practice oscillator. A pair of modified six-transistor radios serve as the receivers. Add a \$20

radio-control model servo, and most of the electronic circuits required are accounted for. You will have about \$65 invested in the system described here.

The first step in construction is to build the model car which will house the receivers and servo. I used a 21-inch model of a Corvette Sting Ray, because the front wheels are steerable and there is plenty of room for the circuitry. I bought this Monogram kit (No. PC126) at a hobby shop for \$11.

Some modification is necessary to leave room for the circuitry. Do not install the engine, radiator assembly, battery or steering column and gear housing. Follow the kit instructions for the rest of the assembly, but don't glue the



Scale-model car has two transistor receivers in the engine compartment. Loopstick antennas protrude beneath front bumper, pick up signal from road antenna.

body to the chassis. Set the finished car aside temporarily.

I used an Ancco *Multi-Servo*, model 2RL. This assembled servo contains a seven-transistor amplifier. It is available for \$19.95 from Ancco Engineering Co., 7714 Colfax Ave. So., Minneapolis, Minn. 55433.

Assemble a battery pack by laying five C-cells side by side, with every other positive pole facing up (three up and two down). Reinforce the cells in this arrangement, and tape them together. This arrangement is necessary so that the pack will fit inside the model. Solder the colored wires of the servo to the batteries as shown in Fig. 1, either directly or through a four-pin connector. Later, when the switch and battery pack are permanently mounted, the length of these battery wires may have to be changed.

The positive bias signals are applied between the yellow and white wires for one direction of servo-bar movement, and between the orange and white wires for the opposite direction of travel. The white is common.

To test the servo operation, turn on the switch and connect the yellow and white wires to the adjustable bias supply shown in Fig. 2. The servo will trigger and the servo bar will move to the right when the bias reaches 1.4 volts. Lowering the bias to 0.5 volt or less will allow the bar to return to center.

With the servo I used, however, when the orange wire is connected instead of the yellow, any level of bias—even a short circuit—will trigger the servo. With this unsymmetrical operation, the car can't be controlled correctly. I corrected this by inserting a pot and resistor (Fig. 1) in series with the orange wire. With the resistance set to about 55K, the bar will move to the left at about 8 volts, and will not return to the center until the bias drops almost to zero. With a 1-volt bias on the yellow wire, the orange-wire voltage need only drop to 4 to allow a return. As you can see, the bias on the yellow wire can affect the bias requirements of the orange wire. The reverse is also true.

The servo can now be mounted in the chassis. Position the servo so that its arm is at the bottom, about 1/8 inch above and parallel with the tie rod between the front wheels. The inverted printing on the servo faces toward the rear wheels. To get a vertical mounting, cut or melt away whatever is necessary of the engine mounts. The top of the bar may have to be flattened so that it will not rub on the servo when the wheels are turned. Fashion angle brackets from sheet metal and mount the servo securely to the chassis.

Attach each end of the servo arm to the tie bar. One method of doing this is to glue pieces of scrap plastic upright on the tie bar, in line with the ends of

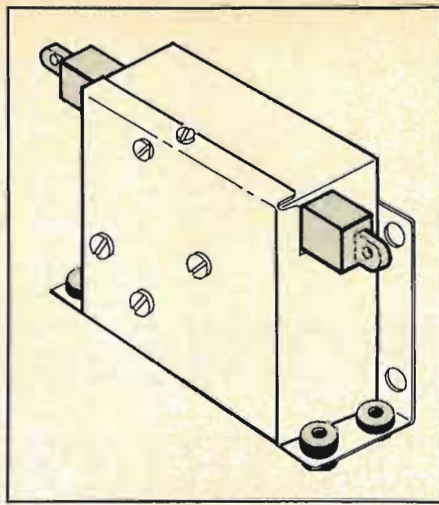

Bidirectional servo steers the model car. Shaded bar attaches to tie rods and turns wheels when driven by motor inside.

the servo arm. Drill a small hole in each of the vertical plastic extensions, and attach these extensions to the ends of the servo arm with No. 22 wire. Be very sure the servo arm is at its center of travel and the front wheels face exactly straight ahead.

Now alternate the bias signal between the two bias input wires. The wheels should move smoothly from side to side and should face straight ahead when the bias is removed. Make sure the tie rod doesn't bind on anything. There should be very little play in the connection between the servo and the tie rod, for best operation.

Now set up the transmitter and receivers. Connect the earphone output

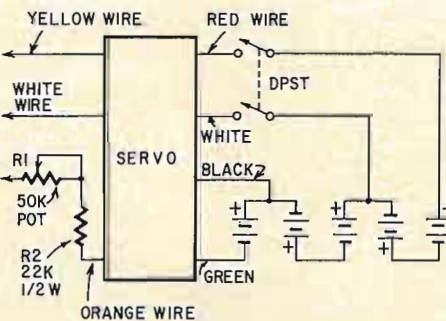

Fig. 1—This is wiring diagram of power supply for servo. The actual lead length is determined by final mounting in car. R1 may be necessary with some servos.

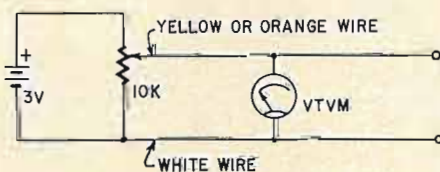

Fig. 2—Test hookup for adjusting servo operation before connecting it to the two transistor receivers and mounting in car.

of any small audio generator to the microphone input of a 100-mW broadcast-band transmitter. Tune the transmitter to a clear spot on the broadcast band. The audio tone must be stable and noise-free.

Both six-transistor radios must have audio output transformers feeding the speakers, instead of impedance-matching transistors. So they will fit side by side in the model car, the width of each circuit board should not exceed 2 3/8 inches. Also, be sure to get radios with the tuning capacitor and volume control knobs mounted on the same side of the circuit board. These will be adjusted repeatedly and must be easily accessible.

Remove and discard the cases. Unsolder the speaker wires from the circuit board, but leave the earphone jack connected if you do not have access to an oscilloscope. Solder a few inches of insulated stranded wire to each side of the primary of the output transformers. To obtain the necessary high output voltage, the signal is taken from this point on the receivers.

Using insulated stranded wire, carefully extend each wire from the receiving antennas of the receivers by about 6 inches. Tape the insulated splices to each antenna so the wires do not pull loose.

Using insulated solid wire, attach the receivers to a 4 1/2 x 5-inch piece of phenolic terminal board (use Fig. 3 as a reference). Remember that the volume and tuning controls must be accessible. Now wire the antennas to the 1 1/2 x 5-inch piece of prepunched board. They should be spaced 3 inches apart in the position shown.

On the unused portion of the large board, mount the dpst servo-battery switch, and mount and connect one dpst or two spst switches in series with the radio batteries. These batteries will be mounted in front of the servo, so extend the wires to the battery clip by several inches. Use a sheet-metal bracket to mount the 50K pot which is connected to the orange wire.

The rest of the board is used for the bias rectifier circuits. Wire these six components together as shown in Fig. 4. Attach terminals to the board so the receiver's audio output levels and the servo's dc input levels can be easily measured. Connecting the receiver outputs and the yellow, white and orange servo wires to the rectifier terminals completes the wiring.

Place the body on the chassis, and insert the receiver assembly between the wheel wells so the fronts of the receivers and wheel wells are in line. The mounting board will rest on the servo, and can be secured with angle brackets to the sides of the wheel wells. Fit the battery pack between the receivers and

the front of the car, where the radiator should be. Note where the chassis stops the pack from seating properly, remove the body, and cut these parts of the chassis away with a heated knifeblade.

The receiver antennas can now be attached to the underside of the car. Position the fronts of the antennas so they are approximately in line with the fronts of the wheels, and bolt the mounting board to the chassis. Make sure the antennas are equal distances from the centerline of the car. The mounting board should not touch any part of the steering linkage.

Now connect the pair of 9-volt radio batteries to the battery clips, and tape these batteries in place under the receivers, in front of the servo. Again fit the body in place and insert the battery pack. When these batteries are connected, the system is ready to be adjusted and tested.

The receivers must be adjusted to give the required audio levels, and tuned by measuring both the receiver and rectifier-filter outputs. They can be tuned by listening to the audio tones from earphones plugged into the earphone jacks, but a scope gives a much better indication.

Tape the single-wire transmitting antenna to a tabletop, and place the car over it. Tune the transmitter to a dead spot on the broadcast band, and tune the receivers to the audio signal. Be sure both receivers are receiving the fundamental frequency and not an image or a harmonic. The right and left dc outputs from the rectifier-filter must be of correct polarity, and each output should change in level separately as the receivers' volume controls are adjusted.

Position the car so that its left receiver antenna is over the transmitting antenna, and adjust the volume control of the right receiver for 0.4-volt output. Moving the right antenna closer to the antenna wire should raise the output to 1.5 volts. The output of the left receiver should vary from 8 volts to under 3 when the car is moved from side to side.

If either output doesn't vary the required amount, the receivers may be receiving so much signal that the first audio stage of the receiver is being overdriven. Try reducing the modulation percentage of the transmitted signal. Also, try detuning the receivers so that the audio output is about one-fourth the output level the receiver gives when tuned directly on station. By trying different adjustments, you will quickly find the best settings for your system.

When the outputs are satisfactory, turn on the servo switch. Moving the car from side to side should now control the steering of the car. If the wheels turn faster to the right than to the left, or vice versa, adjust the pot in series with the orange wire.

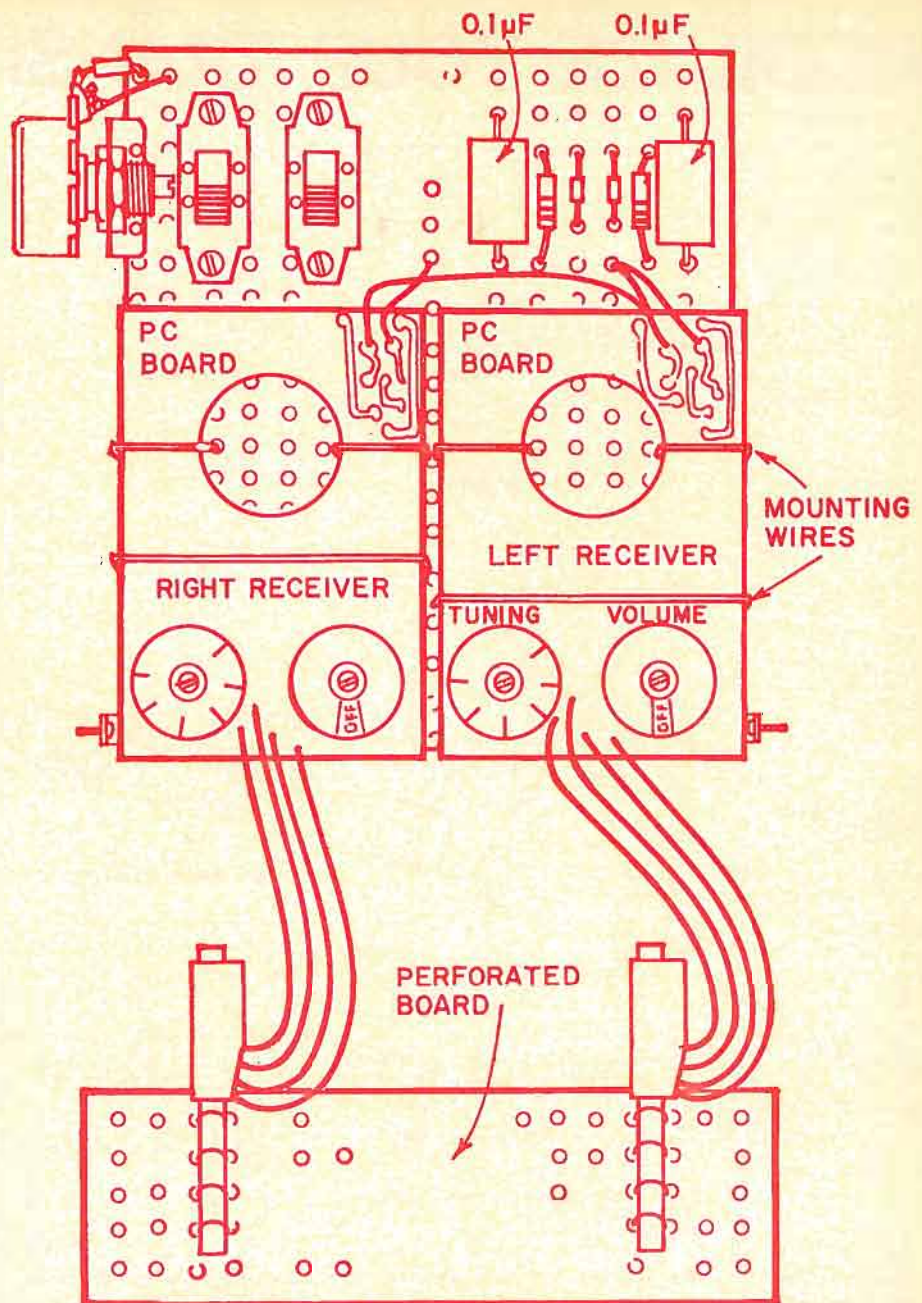

Fig. 3—Two ordinary portable transistor receivers are mounted on a perforated board together with additional components shown below. Receiver speakers and cases are not used. The tuning and volume dials must be accessible from the top.

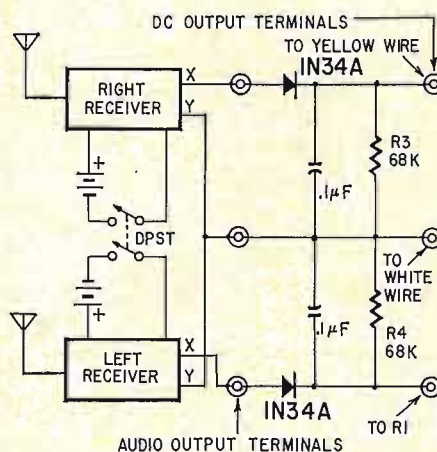

Fig. 4—Circuit arrangement of receiver outputs. Audio outputs used to set bias.

The car will follow a transmitting wire taped to the floor, as long as the wire doesn't turn more sharply than the car can. The transit time of the servo (the time the bar requires to move from center to one side) limits the speed at which the car will track, so don't propel the car too fast.

My system was built as a science project, and the steering was demonstrated by moving the transmitting antenna from side to side under the car. Some builders may prefer to motorize the car's rear wheels, or buy a car with a motor already installed. Either way, this model effectively demonstrates an interesting automatic guidance system which may one day help us to make better and safer use of our freeways. END

MOBIL-IZE YOUR TRANSISTOR RADIO

These modifications can extend the usefulness of ordinary pocket transistor radios for auto use.

By JAMES E. PUGH, JR.

THIS SIMPLE ADAPTER, WHICH ALLOWS your transistor portable to be connected directly to a conventional auto antenna, and the inexpensive booster amplifier designed to be driven by the transistor radio, make it easy to use your radio in a car or boat. Operating costs are negligible because the radio operates at a very low level and the power amplifier operates from the vehicle battery.

Although transistor portables can be used as-is in automobiles or boats, their performance is generally marginal because of inadequate station pickup and high noise inside the vehicle. Also, their battery life is short, because the volume must be run higher than is normal for these sets.

Here, easy-disconnect jacks and plugs and an inexpensive magnetic radio mount make it simple to install the set or to remove it for use on the street or beach. Identical installations in several

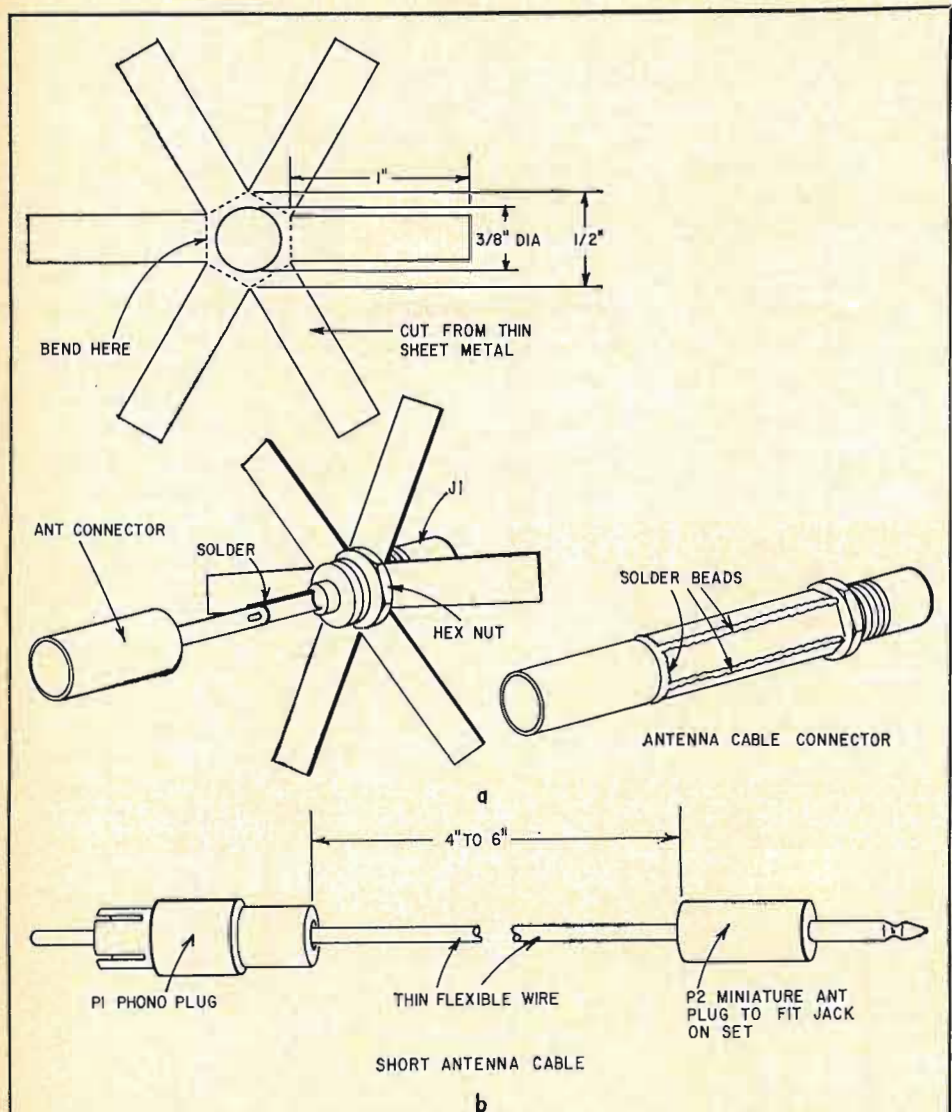

Fig. 1-a—How to make adapter for coax plug on auto antenna, to make it fit external antenna jack on transistor portable. b—Line from antenna cable to receiver.

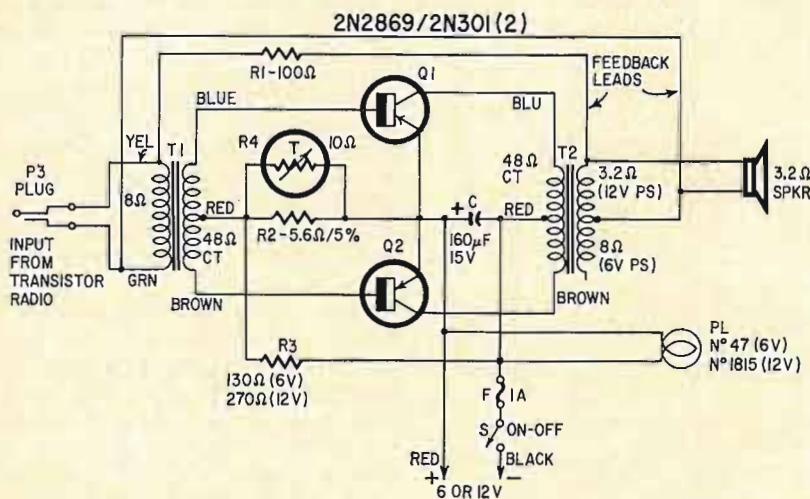

Fig. 2—Circuit of simple, stable push-pull power amplifier to boost volume to on-the-road levels. Unit will work with 6- or 12-volt systems, negative or positive ground.

Parts List

Antenna Adapter:

- J1—phono jack, rear mount type, (Switchcraft 3501FR or equiv.)
- J2—antenna connector, Cinch-Jones 81C
- J3—subminiature phone jack
- P1—phono plug, shielded, Switchcraft 3502
- P2—subminiature phone plug

Radio Mount:

- Magnetic transistor-radio holder, Cardio-Master. (Cat. No. 11 C 1303, Lafayette Radio Electronics, 111 Jericho Turnpike, Syosset, L.I., N.Y.)

Power Amplifier:

- C1—160 μ F, 15 volts, electrolytic
- F—fuse, 1 ampere, type 3AG or AGC
- P3—subminiature phone plug (Lafayette 99 C 6210 or equivalent) to match set
- PL—pilot lamp: No. 1815 (for 12 volts) or No. 47 (for 6 volts)
- Q1, Q2—2N2869/2N301 (RCA)
- R1—100 ohms, 1/2 watt, 10%
- R2—5.6 ohms, 1/2 watt, 5%
- R3—270 ohms (for 12 volts) or 130 ohms (for 6 volts) 1 watt, 10% (130 ohms usually available only in 5%)
- R4—thermistor, 10 ohms at 25°C (Fenwal NB11J1 or equivalent). Fenwal thermistors are sold by Allied Radio, 100 N. Western Ave., Chicago, Ill. 60608
- S—spst toggle switch
- SPKR—size to suit car or boat; voice coil 3.2-4 ohms, power capacity 4 to 6 watts
- T1—transistor transformer, 8-ohm pri to 48-ohm CT sec (Argonne AR-172 or equivalent). Argonne transformers are sold by Lafayette Radio Corp., 111 Jericho Turnpike, Syosset, N.Y. 11791
- T2—transistorized transformer, 48-ohm CT pri to 3.2, 8, 16-ohm sec (Thordarson TR-61 or equivalent)

- Fuse holder, pilot-lamp socket, chassis, transistor-insulating mounting hardware, miscellaneous hardware

vehicles will make your radio even more useful, since the one radio will serve all vehicles.

The antenna adapter

The antenna adapter consists of two parts, as shown in Fig. 1. Solder the inner conductors of the two jacks together, making sure their shells are aligned properly. Cut the six-armed piece from thin sheet metal (a flat section of a tin can will be fine) and bend the arms forward slightly. Flatten the area around the $\frac{3}{8}$ -inch hole with a hammer while backing it inside with a small metal rod. Solder this piece to the large flat washer supplied with the phono jack, fasten it to the jack with a $\frac{3}{8}$ -inch nut, and bend the arms forward until they contact the shell of the antenna jack. Curve the ends for a good fit, and solder all seams and the surfaces where the arms contact the jack. Remove rough spots with a file, and clean off solder flux with alcohol.

The power amplifier

The amplifier is on a 6 x 4 x 2 inch aluminum chassis. Mount the transistors on the outside across the top on a line 3 inches from one end. The thermistor goes under the chassis midway between the transistors to insure a minimum of temperature difference.

The thermistor mount is fabricated from a small paper fastener soldered to the head of a 6-32 x $\frac{1}{8}$ -inch machine screw. Bend the thermistor leads carefully and hold them with a heat sink or pliers while you solder. Two small squares of mica insulate the two conductive surfaces of the thermistor from its metal holder. Center these insulators and fasten them with a few dabs of household cement.

The amplifier can be used on a 6- or 12-volt system. Connect as indicated in Fig. 2 and label the chassis to show the correct supply voltage and polarity. Note that only R3, PL and the T2 secondary connections need to be changed for the different supply voltage.

Correct feedback polarity will cause the output to drop slightly; the wrong polarity will cause the amplifier to oscillate. If it oscillates, reverse the feedback leads or interchange the leads to any one transformer winding. If you like an accentuated bass, connect a capacitor of about 1 or 2 μF across R1.

Installation

The antenna adapter, amplifier input jack, pilot lamp and switch can be mounted in any convenient place. If you don't smoke, the ashtray may work fine. Simply make a panel to fit the available space and mount the parts on it.

Mount the amplifier in a location away from any heat source such as the

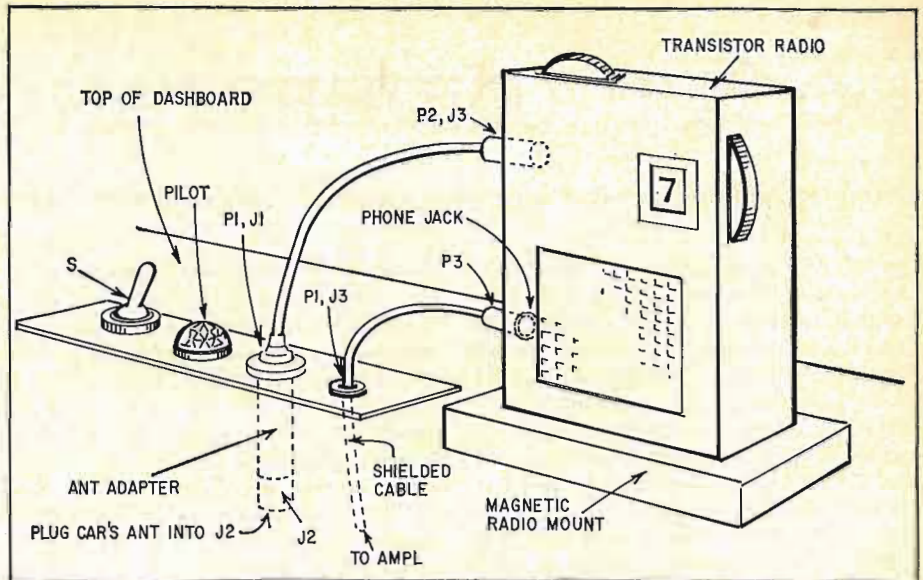

Fig. 3—Subpanel simplifies connections and makes installation and removal easier.

heater, windshield defroster or engine.

A suitable mount for most radios is the Cardio-Master shown in Fig. 3. It has a very powerful magnetic base that holds firmly to any steel surface. The external antenna used in this installation makes radio orientation unimportant. For installation in boats with a wooden instrument panel, a neat stainless steel plate can be fastened in a dry place.

If you install a set in a boat, mount all parts where they will be protected from spray. Also, lightning protection *must* be provided on any boat, because a whip antenna standing clear of other parts of the boat is an excellent lightning attractor. Use a lightning arrester and, if possible, install an air terminal at a level higher than that of the antenna.

Install ignition-noise suppression equipment as required.

How it works

The amplifier uses two power transistors in a class-B push-pull circuit for high efficiency, more than adequate output, and low distortion. The two transistors are biased for 50–60 mA idling current, and the thermistor holds the bias constant over a wide temperature range.

The low input impedance matches the output of most transistor radios. With a 12-volt battery, maximum output will be about 6 watts. With a 6-volt battery, and with the circuit wired as shown for 6 volts, the maximum output will be about 3.75 watts. At these levels the radio and the amplifier will be practically loading.

Used with this power amplifier, the transistor portable will need to put out only 25 to 50 mW for full amplifier output. Since the radio's current drain will then be only slightly above the idling current, the radio battery will have a much longer life than before.

Modifications

If your radio doesn't have an external antenna jack, one can be installed as shown in Fig. 4. Mount the jack near the built-in ferrite antenna and connect the capacitor as shown. Remove the radio from its case to avoid damage while you drill.

Also, the radio will need an output jack with 4 to 16 ohms source impedance. Most sets have one for connecting to an earphone, but if yours doesn't—or if it uses a high impedance earphone—install one as shown in Fig. 5. END

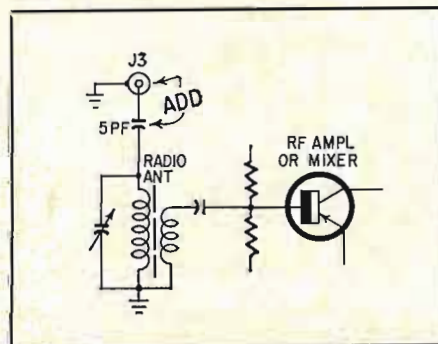

Fig. 4—New antenna input for portable.

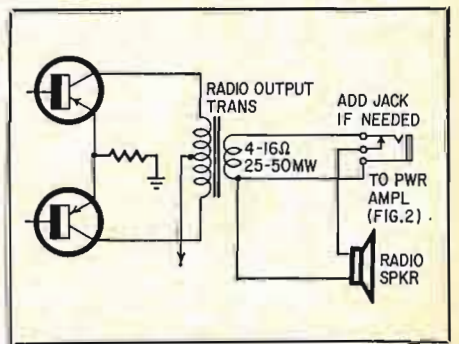

Fig. 5—Audio output change in receiver.

DO YOU UNDERSTAND SQUELCH?

There are only three basic ways they operate By JOHN D. LENK

MOST RECEIVERS USED IN MOBILE COMMUNICATION have a squelch circuit. This applies to both auto and marine two-way radio systems. A squelch circuit does not eliminate interference noise (as does suppression, filtering, and shielding) or reduce its volume (as does a noise limiter). The squelch silences receiver hiss until a signal is received.

A squelch circuit is like a gate in the audio section that opens when the signal is not there. Usually the squelch can be set to remain closed until signals of certain strength are present. The *squelch control* sets the signal level at which the gate opens and closes. Some receivers have an override button that momentarily cuts out squelch action so the operator can listen for weak signals without changing the squelch-control setting.

There are three sources in a receiver to activate the squelch circuit or open the gate—the negative automatic volume control (avc) voltage, the i.f. amplifier screen voltage, and background noise

generated by the receiver front end.

Logical points for picking off a squelch-control signal in a typical AM receiver are indicated in Fig. 1. A well-filtered avc voltage can be taken off at point 1 or 9. The i.f. amplifier screen (point 3) is the best pickoff point for a *positive* dc voltage that will *increase* in the presence of a signal. The i.f. plate (point 4) could be used, but plate variation in a pentode is usually too small to be practical. The i.f. amplifier cathode (point 2) produces a *positive* voltage that *decreases* with signal strength.

Squelch that operates from background noise uses a special arrangement that rectifies the noise signals to develop a dc voltage to operate the squelch circuit. Background noise for this type of squelch can be picked off at points 5, 6, 7, 8 and 9; 5 and 6 are used most.

Avc-actuated circuits

A basic squelch circuit controlled by avc voltage is shown in Fig. 2. Tube V1 is the audio amplifier, and V2 is the

squelch tube. In the absence of a strong rf signal, the negative avc voltage applied to the control grid of V2 is low, so V2 conducts heavily. Cathode current for V2 flows through resistor R1, which is also connected to the cathode of V1. The large voltage drop across R1 makes the cathode of V1 positive with respect to the grid, cutting it off. No audio can pass from the detector to the output and speaker.

In the presence of a good signal, the negative avc voltage builds up at the grid of V2, reducing the current through V2. The voltage drop across R1 is reduced, the cutoff bias on V1 is lowered, and audio signals can be amplified. The *squelch threshold* point—how much signal it takes to open the audio circuit so sound can be heard in the speaker—is determined by the value of R2 and R1. The threshold can be varied if either R1 or R2 is adjustable.

Screen-actuated circuits

Two circuits using the voltage from the screen of an i.f. tube for squelch operation are shown in Figs. 3 and 4. Fig. 3 is a diode squelch circuit, while Fig. 4 controls the audio triode.

The diode of Fig. 3 can be either a tube or a semiconductor. The cathode of the diode receives a positive voltage through R1; its value is determined by dividers R2–R3–R4. The anode receives its voltage through R6 from the screen of an i.f. amplifier tube. In the absence of a signal, the cathode is more positive than the anode, so the diode does not conduct and the audio is blocked. Resistor R3 is the threshold control and permits the bias to be set as desired.

In the presence of a signal, the screen voltage of the i.f. amplifier (and at the junction of R5 and R6) rises. Transmitted to the anode through R6, this increases the anode voltage at the diode. When the signal is strong enough (reaches the threshold value) that the screen-voltage pushes the anode voltage above that of the cathode, the diode conducts. Audio signals pass through to the audio amplifier stages and then to the speaker.

Audio triode V of Fig. 4 is biased so that the grid will be highly negative with respect to the cathode in the absence of a signal. The triode cannot conduct. The grid voltage comes through R1 from divider R3–R4–R5–R6. Resistor R3 is connected to a negative voltage and R2 and R6 to B+. Control R4 sets the threshold by determining the no-signal bias. The i.f. screen is connected to the junction of R5 and R6.

Fig. 1—This AM receiver has several takeoff points for operation of squelch circuit. Some derive control voltage from avc, but points 5 through 9 are triggered by receiver background noise. Both positive and negative dc are available.

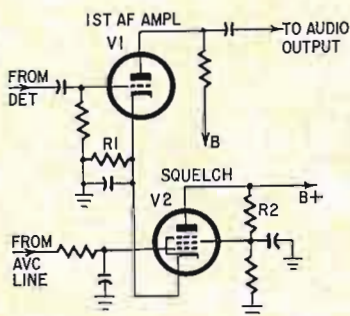
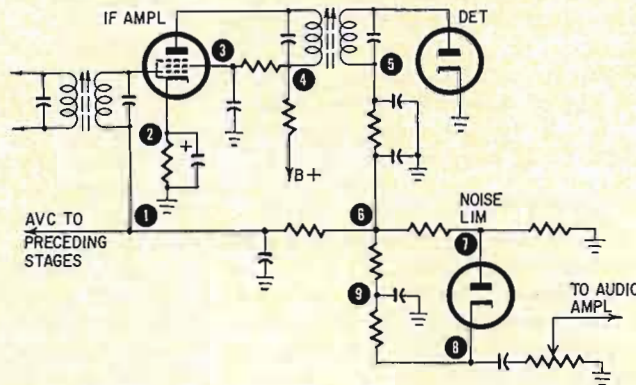

Fig. 2—More rf signal raises i.f. avc voltage. As high conduction of V2 diminishes, cutoff voltage on R1 drops.

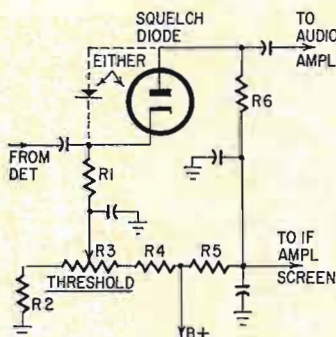

Fig. 3—Conduction or nonconduction of diode causes squelch action. At high volume, capacitive leakover can occur.

With a strong signal, the screen voltage rises, increasing the positive voltage at the junction of R5 and R6. This changes the drop across R3, R4 and R5 so that the bias voltage at the slider is now positive (or much less negative) with respect to ground. The change in grid bias permits V to conduct, passing audio from the detector to the audio output stages and speaker.

A transistorized improvement

Squelch circuits that operate from avc or i.f. screen voltages have one basic drawback: Both circuits can also be actuated by strong interference-noise signals as well as the desired transmitter signal. A sharp increase in interference noise—such as auto ignition bursts—causes the squelch to open and pass audio. If the squelch threshold is set to overcome this high interfering noise, the receiver will be insensitive to weak transmitter signals. Therefore, the weak signals will not be heard.

Fig. 5 is a simplified schematic of a squelch circuit that partly overcomes this drawback. This one is used in a transistor receiver. Transistor Q1 is the squelch stage and Q2 is the controlled audio amplifier. Audio signal is applied to the base of Q2. If the rf signal is strong enough to overcome the squelch threshold, Q2 operates and the amplified audio signal is fed to the second audio amplifier.

Squelch threshold is set by control R2, which controls forward bias (positive) applied to the base of Q1. The actuating voltage change comes from the effect of mixer and rf amplifier collector current, which flows through R1. When no rf signal is being received, the drop across R1 is 1.5 volts; when a strong signal is being received it falls to 0.2 volt, because of avc action on the mixer and rf amplifier.

Without a signal, Q1 is forward-biased and conducts. A dc voltage of about -4.8 is developed across R3. This biases Q2 to cutoff. When a strong rf signal is received, R1's voltage drops low enough that Q1 stops conducting. Transistor Q2 starts, allowing the audio signal to pass through.

Noise-operated squelch

A noise-type of squelch circuit is popular in FM communications receivers, and is working its way into the more expensive AM sets. Fig. 6 shows one such circuit developed by Hammarlund.

The detector output of the receiver goes to a high-pass filter and a low-pass filter to split noise and normal audio. Audio signals go through low-pass filter R1-C1-C2 and volume control R2 to the input of V3. Whenever V3 is conducting, audio signals can pass through to the output stage.

Background noise signals from the

front end of the set are applied through highpass filter C3-C4-R3-R4 to the input of V1, a noise amplifier. The output of V1 is applied to the input of V2 through C5. How much V2 conducts is related to the amount of noise received from V1; the point at which conduction starts is determined by squelch threshold control R5 which sets the cathode voltage. As long as V2 is conducting, its plate voltage will be low. This voltage is applied to the grid of V3 through R6, and keeps V3 cut off as long as signals are so weak the background noise would drown them out.

In the presence of a usable signal, background noise in the front end of the receiver drops off. V1 amplifies less noise, which reduces conduction in V2. Its plate voltage increases, raising the

grid bias of V3 to a point where the tube can conduct and pass the audio signals. Threshold control R5 in the cathode of V2 permits the operator to select the strength of signal at which the squelch will open.

FM receivers and noise

Squelch circuits in FM receivers often interfere with tracking down external noise sources, or even the checking for the presence of noise. Normally, FM receivers don't reproduce amplitude-modulated noise such as ignition interference. However, strong interference noise can overload the receiver rf and i.f. circuits, causing them to become less sensitive.

If the squelch circuit has an override button or control, it is a simple matter to bypass the squelch momentarily and check receiver sensitivity. If there is no override control, sensitivity must be judged while a signal is being received. If you are near the base station, the strong signal will overcome the noise and you still will not notice the loss of sensitivity. If you make the test at some distance from the base station, the signal will get through but will appear weak. It is easy to confuse interference noise with a weak receiver or a weak station signal. These are good points to keep in mind if you have to service an intermittent-squelch or weak-reception problem. END

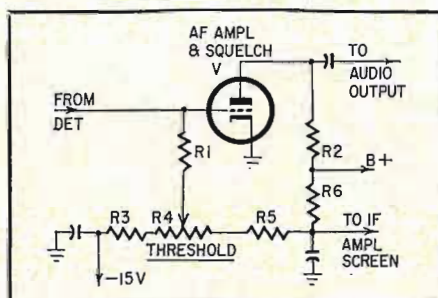

Fig. 4—*I.f. screen squelch applied direct to audio amplifier usually provides more solid lockout than does diode-type circuit.*

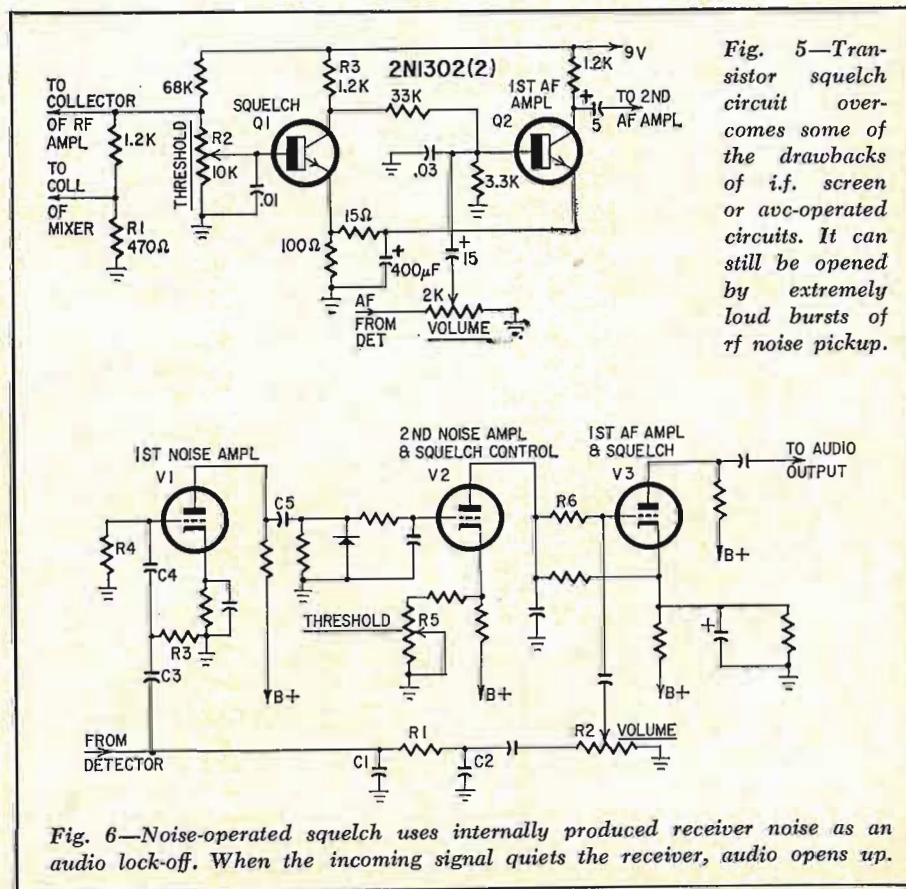

Fig. 5—*Transistor squelch circuit overcomes some of the drawbacks of i.f. screen or avc-operated circuits. It can still be opened by extremely loud bursts of rf noise pickup.*

Fig. 6—*Noise-operated squelch uses internally produced receiver noise as an audio lock-off. When the incoming signal quiets the receiver, audio opens up.*

Color AFC Adjustments are Really Simple

If you think they should be difficult, they will **By JACK DARR**

YOU'LL FIND VERY LITTLE ORIGINAL trouble in color afc (afpc) circuits. The most common cause, like i.f. misalignment in old radios, is due to REA (Random Experimental Adjustments) in the field. My own (home) sets, over a period of 12 years, have never given any trouble, and I've run into only two cases in field work. (One, I blush to admit, was due to my own REA—I got the twiddling-stick in the wrong coil by mistake! Fortunately, I saw what was happening and was able to get it back without any trouble—the result of living a clean life, no doubt.)

I've just finished the other one. This was an almost-brand-new set that had given color-sync trouble for some time. Several technicians had worked on it by the time I got it, and the latest poor soul admitted he'd run through the realignment procedure several times without any luck.

In the process of straightening the thing out, I made a discovery (by making a mistake, the way most discoveries are made). I was slavishly following the procedures given in "the book," without thinking. There's a better way.

A simple circuit

The color-afc stage (Fig. 1) closely resembles a horizontal afc circuit. Don't forget that, for it's important to your "attack." It uses *exactly the same method of adjustment!*

To set up a horizontal-oscillator-afc circuit, disable the afc and all stabilization. Then turn the hold control to make the oscillator run on frequency without any control at all. What you are doing is comparing its free-wheeling frequency with the horizontal sync signal

itself. Then, put the stabilization back in, and check the result. Finally, reactivate the afc. If adding a stage makes the oscillator go off frequency, you know that circuit is defective. So you fix it.

Unlike the horizontal oscillator, whose frequency is RLC-controlled, the color afc has a nice stable crystal-controlled Pierce oscillator to start with. This is a good thing! Why? Well, this circuit must, when you finish, run inside a tolerance of less than one-tenth of one color-bar cycle, or less than 1,575 Hz away from the color reference point of 3.579545 MHz.

You don't believe this? Try turning the tint control on a color set to change red to green. Y'know how far that oscillator shifted in frequency? About *one-tenth* of one color-bar cycle—36 electrical degrees! So, little less than perfection will do. Don't sweat; this is easier done than you might think.

The symptoms of poor color sync are obvious. The set will drop out when you get a sudden change: from program to commercial, on changing stations, etc. In very bad cases, you'll even lose color sync if you move the horizontal hold control! You may get *strong* colors, very vivid, but they lose sync, making rainbows and barber poles of red, blue and green bands chasing one another up and down the screen. If you want to, you can tell how far off you are by counting the number of "sets" of colors. Each one is a shift of one color-bar cycle.

Now, how to get sync back? The color afpc from an RCA CTC16/17 is shown in Fig. 1. Others will differ, but they'll be similar in principle, so this method should work for all.

The 3.58-MHz local-oscillator signal is compared to the burst frequency. This is done in the color-phase detector, which develops a dc correction voltage

if either signal changes frequency. The oscillator itself is controlled by a *reactance tube*, which looks to the oscillator circuit like either a capacitance or an inductance. The type and amount of reactance are controlled by the dc grid voltage—the correction voltage from the phase detector. When the 3.58-MHz oscillator frequency agrees with the incoming color burst, the reactance tube applies *zero correction*, because its grid voltage is exactly zero. (Remember this!)

The first step in recovering color sync is to check all tubes and their operating voltages, so that you're not taken in by something simple. The burst amplifier and color killer must be working, as well as the 3.58-MHz burst oscillator and control tube. You can check the oscillator's output with a scope, or by hooking a dc vtm to either of the plates or cathodes of the phase detectors (points 1 or 2 in Fig. 1). The CW signals will develop a dc voltage at these points, in direct proportion to the *amplitude* of the 3.58-MHz oscillator output. By using a scope's low-capacitance probe at point C or D (demodulator input), you'll be able to see the CW oscillator signal as a "bar," something like Fig. 2.

The "book" procedure, which is about the same for most sets, calls for grounding the cathode of the burst amplifier at point B to get more burst signal into the phase detector. This stage is gated or keyed during horizontal flyback time by a positive-going pulse from the flyback, so that it conducts only during the sync interval. Therefore, it picks off only the burst and feeds it to the burst transformer and the phase detector.

Next, ground the grid of the reactance tube at test point A. This clamps the grid at zero volts, which is exactly the condition you would find when a

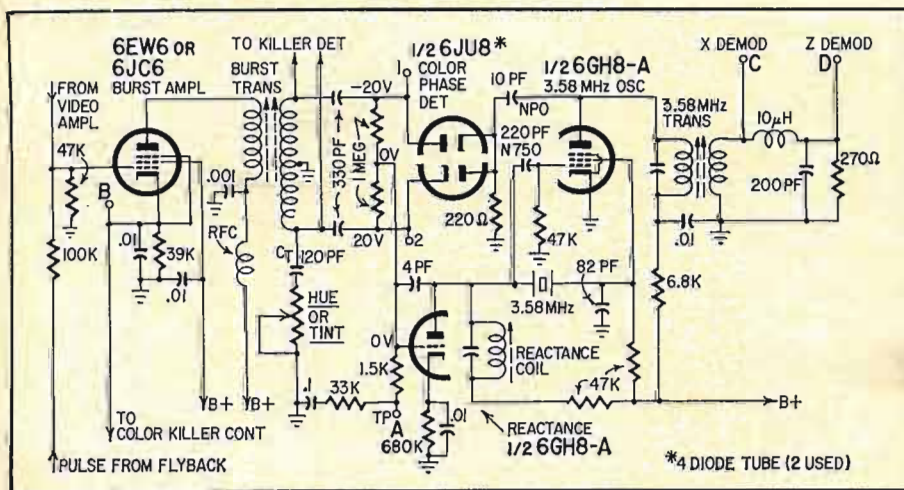

Fig. 1—This circuit should look familiar to anyone who's been working on black-and-white receivers. Color afc uses the same method of adjustment as horizontal afc.

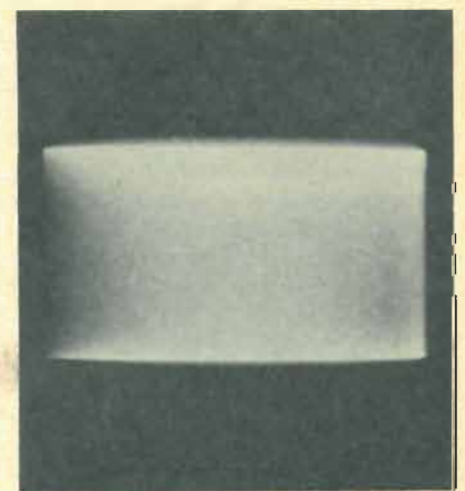

Fig. 2—Output signal from 3.58-MHz local oscillator appears this way on shop scope.

color program is tuned in with the system working perfectly. In other words, there'd be no correction voltage with everything right on the nose!

Now the 3.58-MHz oscillator is working—or is it? Check by reading the dc voltage developed at the phase detector, between point 1 or 2 and ground. If necessary, tune the 3.58-MHz oscillator transformer for maximum reading at the diodes. No dc voltage here, no oscillator. In some cases, you may have to move the reactance-coil adjustment to get the oscillator to start. Since this is a modified Pierce oscillator in most sets, it'll usually take off. (The crystal is connected between the control grid and the screen grid, which serves as oscillator plate.)

By taking away any correction voltage, you make the oscillator run "free-wheeling." In this condition, it ought to be running very close to 3.579545 MHz. (Notice I quit saying 3.58?) It *ought* to be right on the nose, and a surprising number actually are! Considering that this is just a "bare" crystal—no ovens, etc., to compensate for things—it's *darn* good.

Next, adjust the oscillator transformer for maximum output amplitude, as shown by the scope pattern or the dc voltage reading on the diodes. Don't be concerned with phasing yet; you want maximum output in this step.

This is the point where the book and I part company. It recommends hooking a color-bar generator to the antenna

terminals and adjusting for zero beat—until the color bars stand still on the screen, in their proper order. Fine. If you have a keyed-rainbow or NTSC-type generator, with a frequency accuracy of .05% or better. I'll accept that! Otherwise, *no!*

Here's my standard procedure: Ground the grid of the reactance tube, thus lifting oscillator control. Feed a color signal from the bar generator through the antenna terminals. Make a slight adjustment to the reactance coil, until you get a zero-beat between the 3.58-MHz oscillator and the incoming burst. When this happens, you'll see the color signals stand still on the screen—an indication that the oscillator is exactly in phase with the burst. Not one color-bar cycle off, but right-smack-on-the-nose.

When the short is removed from the reactance-tube grid, the colors should lock in. Fine—but will they? Yes, on the bar generator, but on an actual color program? Maybe yes, maybe no! It depends on whether you use a poorly controlled generator or a more costly type. From my experience I'd say the chances are that you'll have stable colors, but not necessarily in the right places, unless you really have a good generator.

Here's how you make sure color programs will lock in. Go through the setup procedure to that last step, where you zero-beat the oscillator against the burst. Now, take the bar generator off,

hook an antenna to the set and use the actual color burst from a program! Since the receiver must use this burst to hold color in normal operation, why not use it as a standard for setup?

This technique works every time. Turn the color control a little above normal, so the colors are easier to see from the back of the cabinet. When you finish this adjustment, take off all shorting jumpers, meters, etc., and double-check by changing stations, moving the tint (or hue) control, adjusting fine tuning, and so on. Most important, make sure that color on the screen changes normally when going through the full range of the fine tuning, from "worms" through color to a dull black-and-white picture. The color should slowly fade in intensity, but must not change color (hue), and must not suddenly fall out of color sync when you get near the outer edge of fine tuning!

This must not be taken as being in any way critical of a simple rainbow generator when it is *properly* used. As a source of test color signals—for signal tracing, for demonstrating the ability of a set to show colors, checking the operation of the tint control, and so on—definitely yes. But *not* as a primary frequency standard! It isn't built to do such work, so don't expect it to, any more than you'd expect a \$29.95 rf signal generator to be as accurate and stable as WWV! Use the signal that the set works on as a primary standard, and you're in like Flynn! END

Simple Rf Proximity Detectors

Automated production and manufacturing techniques require electrical and electronic equivalents of the five basic human senses. The proximity probe, for example, functions like the sense of touch

By DELLROYE D. DARLING

IN AN OVERSIMPLIFIED DEFINITION, AUTOMATION is the business of replacing human machine operators with automatic controls. Of the five human senses—sight, touch, hearing, smell and taste—the first two are most commonly replaced by artificial sensors. Photocells function as "eyes" for the machine, while "proximities" simulate the sense of touch.

One of the most popular types of proximity controls is the rf proximity detector. (The name proximity detector means just what it implies—the device will sense objects that are in proximity to or near the device.) The heart of the detector is an unstable oscillator.

The industrial type of rf proximity probe illustrated consists of a box containing the control circuit (an industrial technician would probably call this the

"panel") and a sensing head. An electromagnetic counter, shown connected to the output of the control, has been added to permit the system to be used as a production-line counter.

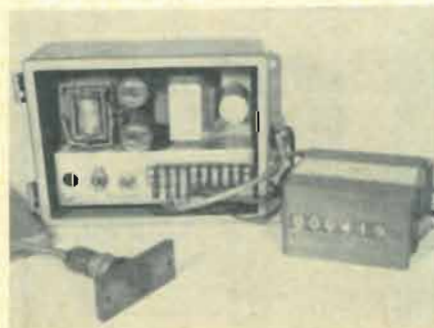

Basic proximity detector is shown with counter and probe in assembly-line system.

The simple control circuit (Fig. 1) consists of an rf oscillator, two untuned rf amplifiers, a bias rectifier and a relay-control tube. Two 6SN7 dual triodes do the whole job. Of course, the panel also includes a power supply.

Output from rf oscillator V1-a is coupled directly to the grid of first amplifier V1-b. The amplified signal is coupled through C1 to V2-b, where it is again amplified. From the plate of this amplifier, the signal is coupled through C2 to bias rectifier D1. The rectified dc voltage appears across C3, where it is applied as a bias voltage to cut off relay-control tube V2-a.

How it works

Take a look at the oscillator portion of the circuit, and you'll notice it doesn't really look like an oscillator. What's missing? You're right—there's no grid capaci-

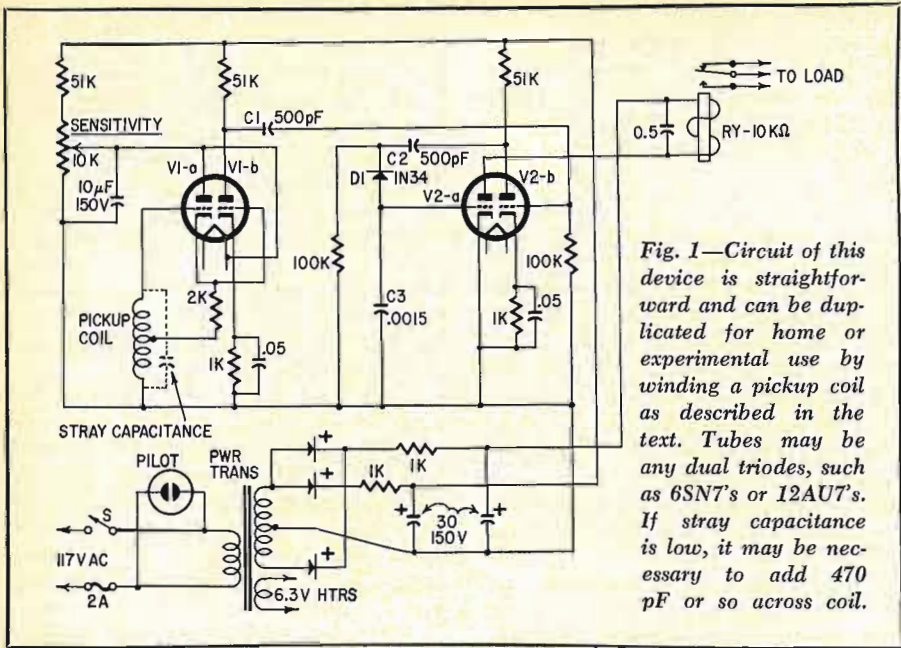

Fig. 1—Circuit of this device is straightforward and can be duplicated for home or experimental use by winding a pickup coil as described in the text. Tubes may be any dual triodes, such as 6SN7's or 12AU7's. If stray capacitance is low, it may be necessary to add 470 pF or so across coil.

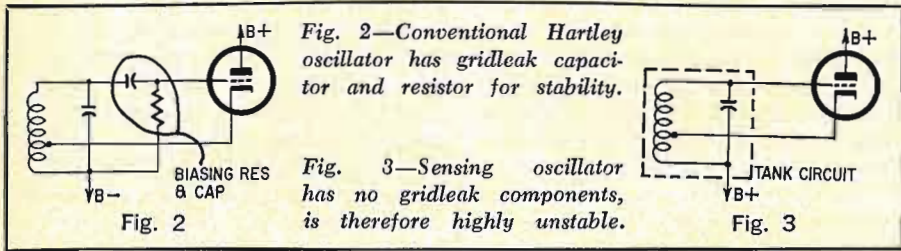

Fig. 2—Conventional Hartley oscillator has gridleak capacitor and resistor for stability.

Fig. 3—Sensing oscillator has no gridleak components, is therefore highly unstable.

tor and no grid-leak resistor. This is the secret of the unstable oscillator. To understand why, let's go back to the basic theory of oscillators.

The usual Hartley oscillator (Fig. 2) consists of a tank circuit (coil and capacitor) which actually does the oscillating. Of course, this tank circuit will not oscillate forever, because it contains losses. So, we add a tube and a power supply. On every cycle of oscillation,

the tube adds enough power (from the power supply) to keep the tank going.

If the oscillator is loaded, the effect is the same as if the tank-circuit losses were increased. The tube has to conduct harder to make up for the increased losses, or the oscillator will stop. This is where the grid capacitor and resistor come in. Every time the oscillating tank circuit drives the grid positive, grid current flows. The cathode-grid circuit of

the tube rectifies this flow and uses it to charge the grid capacitor to the required bias level. If the load on the tank circuit changes, the bias on the grid capacitor changes to increase or decrease conduction of the tube as required to maintain oscillation; the circuit is self-regulating.

The sensing oscillator (Fig. 3) has no grid capacitor or resistor, because it is not meant to be self-regulating. The grid of the tube just keeps going positive and negative as the tube oscillates; there is no bias.

When the oscillator plate voltage is adjusted to the point at which the tube supplies just barely enough kick to keep the tank circuit going, anything that increases the load on the tank will cause oscillation to cease. And that's what makes the rf proximity detector work.

Referring again to Fig. 1, note that the relay tube is held cut off as long as the oscillator section is operating. If the oscillator stops, the relay is energized. It's obvious that we have the means for remote operation of the relay, if we can devise some way to start and stop the oscillator.

Sensing with the probe

What would increase circuit losses in the oscillator sufficiently to interrupt its operation? Well, about the worst thing that can happen to an inductor (like our oscillator coil) is a shorted turn. The alternating magnetic field around the coil will induce a current in that shorted turn, and power will be lost.

The effect is the same when a piece of metal comes near the tank coil; it will act just like a shorted turn (Fig. 4) and the oscillator will stop. Every time a piece of metal is placed near the sensing coil, the oscillator stops, bias disappears from the relay tube, and the relay operates. The connection from the heater to oscillator plate on V1 simply supplies a little signal to get the oscillator going again after it has sensed something.

While the circuitry of the rf proximity detector is fairly simple, uses for the device are countless, especially in manufacturing operations. The circuit is so straightforward, as a matter of fact, that it should be possible for a competent technician to construct a working unit using the component values shown in the schematic of Fig. 1. The only component of any particular complexity is the pickup coil, and it can be wound with any No. 26 to 32 enameled wire. The coil will require about 150 turns, center-tapped, scramble-wound to cover 3/4 to 1 inch on a 1-inch diameter form. If a cable 10 to 15 feet long is used to connect the coil to the main circuit elements, stray capacitance should be sufficient to insure operation. If short connecting leads are used, it may be necessary to add a 470-pF capacitor across the coil.

END



Presence of metal coin increases eddy-current losses of coil, stopping oscillator.

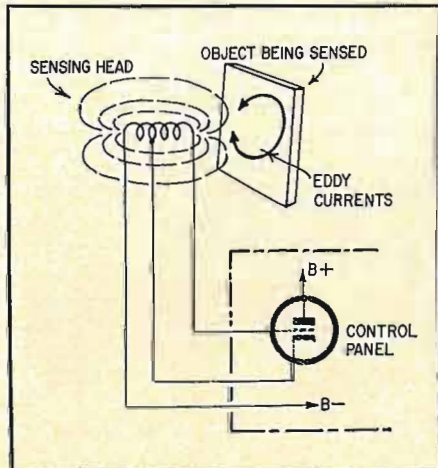

Fig. 4—Eddy-current losses load the coil, causing the oscillator to stop functioning.

A Sample of Scope Analysis

By **ROBERT G. MIDDLETON**

THERE'S NO QUESTION ABOUT IT—THE oscilloscope is an invaluable test instrument. Invaluable, *if* the instrument is functioning properly and the technician using it is aware of its performance characteristics.

The TV service technician is usually confronted with three classes of waveforms: frequency-response curves, complex waveforms and cyclograms. The frequency-response curve is customarily displayed with sine-wave deflection. The complex waveform is displayed on sawtooth deflection or a *linear* time base. The cyclogram, a quadrature display of any two ac voltages in a circuit, is always displayed on a signal-voltage time base.

The scope can indicate a frequency-response curve in four ways, with the frequency increasing or decreasing from left to right, even though the same waveform is being analyzed. Whether the response curve appears in reference or inverted polarity depends on the demodulator polarity, be it a picture detector in the receiver or a probe. Whether the curve appears normal or in mirror image from left to right depends on the phase of the

horizontal deflection voltage. This phase is adjustable, usually by a control on the sweep generator or sometimes on the oscilloscope.

Although the phase-control setting is not changed, the curve reverses left to right when we select a different takeoff point in the tuner or i.f. Thus, if the display at the looker point (mixer-grid test point on a TV tuner) *increases* with frequency from left to right, the display at the mixer plate *decreases* in frequency from left to right. This is because the local oscillator operates below the picture-carrier frequency.

Next, consider complex-waveform displays. A complex waveform appears positive-going or negative-going, depending on the test point in the circuit. In an amplifier stage, for example, the waveform at the plate is an inverted and amplified version of the grid input waveform.

Square waves may be symmetrical or asymmetrical. Thus, pulses merge gradually into square waves as they get wider (their duty cycle is varied)—Fig. 1. Modern square-wave generators often have a control for varying the duty cycle

of the output. Pulse generators for TV are sometimes called crosshatch or dot generators. They are also built into some scopes for calibration and peak-to-peak voltage measurements.

Distortionless reproduction of any waveform requires that the scope be in good operating condition. If, for example, the scope's horizontal amplifier is nonlinear, displays appear distorted. Vertical nonlinearity in the scope amplifier causes compression or clipping. The same fault sometimes results from misadjustment of the scope controls—the vertical step attenuator is turned too high or the vertical vernier attenuator too low.

Complex waveforms often have an indirect relationship to picture-tube patterns in TV receivers. Fig. 2-a shows a video signal which can be traced in the circuit when there's no picture on the screen (Fig. 2-b.)

Bar patterns correspond to square waves combined with sync pulses. A black-gray-white bar (staircase) signal with its horizontal sync pulses is shown in Fig. 3. Though transient spikes appear in the display, they are spurious output from gating circuits in the generator and are disregarded.

Circuit disturbances can cause the waveform distortions illustrated in Fig. 4-a. In this case, direct connection to a grid circuit causes the scope input cable to operate as a tuned stub, resulting in parasitic oscillations. A low-capacitance probe reduces this tendency (Fig. 4-b). In some cases, a series resistor of about 50K must be connected in series with the probe to eliminate these parasitic oscillations. Unless the waveform frequencies are quite high, the series resistor will not seriously affect the wave-shape. END

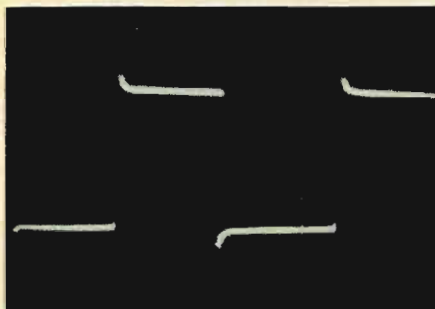
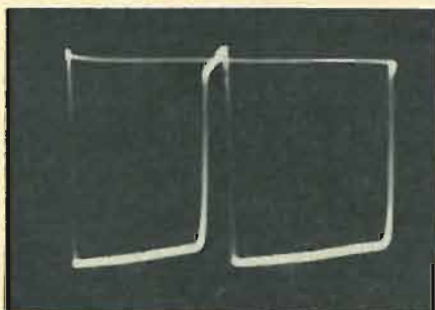
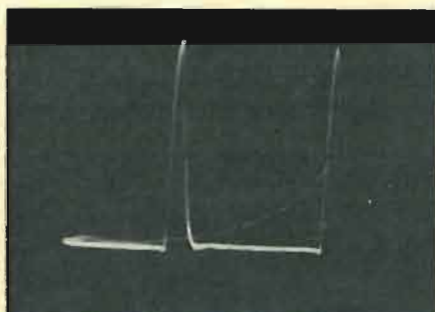

Fig. 1—Pulses (a, b) become square waves (c) as their duty cycles are lengthened.

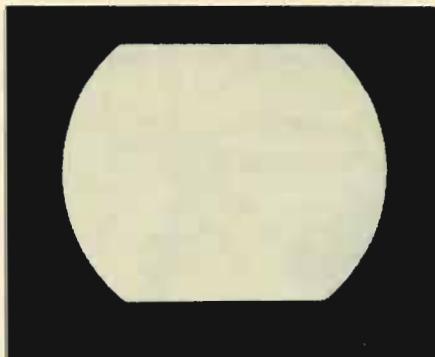

Fig. 2—Trace the video signal (a) through the circuit when TV screen is blank (b).

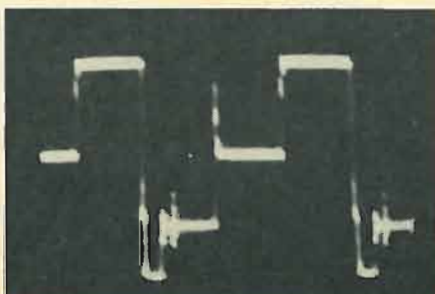

Fig. 3—Staircase video signal produces black, gray and white bars on screen.

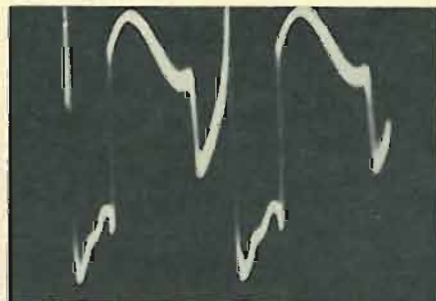

Fig. 4—Direct probe distorts signal (a). Lo-cap probe produces normal pattern (b).

AN ALL-PURPOSE SUB BOX

IF YOU HAVE EVER BUILT, WIRED, ASSEMBLED, DESIGNED, SERVICED OR EXPERIMENTED with a transistor circuit, you will have a special appreciation for this piece of test equipment. If not, file this story where you can find it the day you do your first work with transistors. It will be invaluable. The substitution box described here isn't cheap, but it combines several test items in one compact case: a resistor substitutor, a capacitor substitutor, an af-rf signal tracer, and a test speaker.

The usual resistor box does not provide values common to transistor circuits. Values below 1 ohm are used in most power-transistor circuits for biasing and for limiting collector current to avoid thermal runaway. In design practice, the optimum value for an emitter resistor is often found most quickly by cut-and-try.

Another substitution-box limitation is the large skip between values throughout the ranges provided. This is usually done to make room for values well above 2 meg. But resistors above 2.2 meg are almost never used in transistor circuits, and not too frequently in tube work. Both limitations are eliminated by the resistor section of the Sub Box.

A test unit for design/service of many tube or transistor circuits.

By **LEON A. WORTMAN**

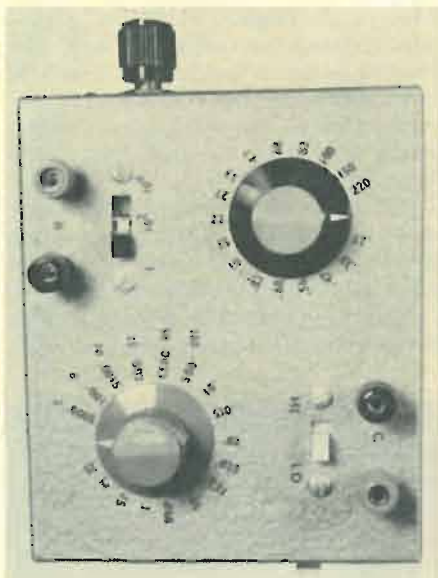

Prototype of Sub Box is lettered roughly, but shows values available at each switch. Side-mounted knob is on volume control.

Capacitor substitution boxes also ignore the transistor man. Their values are fine for high-impedance circuits associated with vacuum tubes, but in transistor work they are almost useless. The usual range is from .0001 to .22 μF . With tubes, .0005 μF is a good rf bypass; .05 μF for coupling; .1 μF for screen-grid bypassing. However, transistors are low-impedance devices and require different values. For example, a coupling capacitor from a transistor collector to the next transistor's base requires 2 μF or more at audio frequencies. Therefore, values most frequently encountered in transistor circuits are an important part of the Sub Box.

What's in it

Resistor and capacitor values have been included for use with all types of circuits—transistor, tube, and hybridized. There are three resistor and two capacitor ranges. They are selected by slide switches S3 and S5.

Resistor values go from 0.27 ohm to 2.2 meg in 51 steps. Resistors below 10 ohms are 2-watt wirewound types; all others are 1-watt carbon types.

The two capacitor ranges are la-

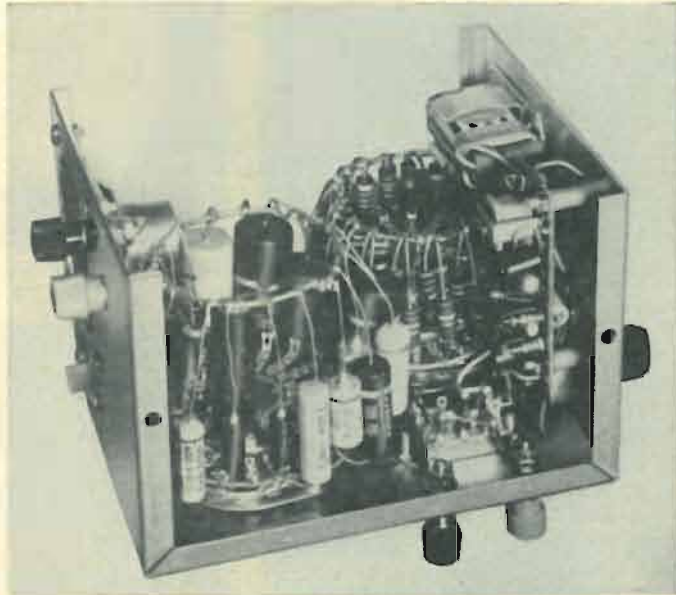
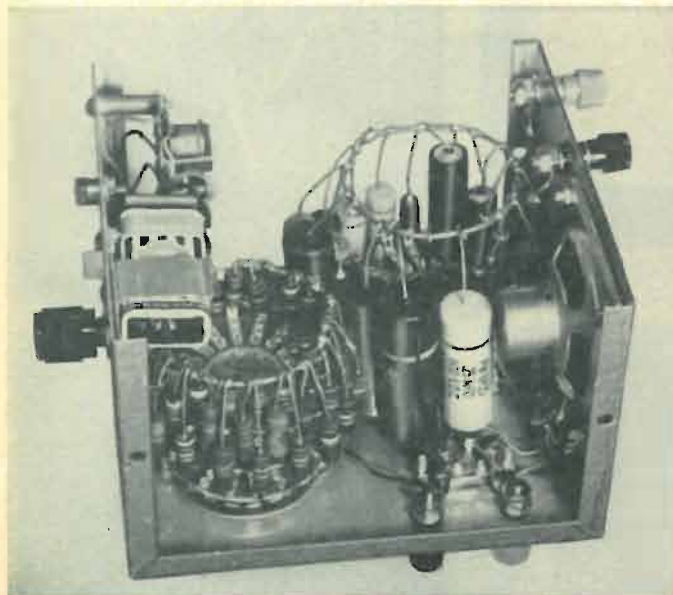

These inside views illustrate gimmicks used for convenience in assembly—rings made of bus bar, on which resistors and capacitors are mounted. One lead from each resistor and capacitor goes to ring, while the other lead is soldered to lug on wafer switch.

PARTS LIST

- C1—6 μ F, 15 volts
- C2, C3—10 μ F, 15 volts
- C4—30 μ F, 10 volts
- C5—50 μ F, 15 volts
- C6—2 μ F, 25 volts
- C7—6 μ F, 25 volts
- C8—10 μ F, 25 volts
- C9—25 μ F, 25 volts
- C10—50 μ F, 25 volts
- C11—160 μ F, 25 volts
- C12—500 pF
- C13—.001 μ F
- C14—.0015 μ F
- C15—.002 μ F
- C16—.0033 μ F
- C17—.005 μ F
- C18—.01 μ F
- C19—.015 μ F
- C20—.02 μ F
- C21—.025 μ F
- C22—.033 μ F
- C23—.05 μ F
- C24—.068 μ F
- C25—.1 μ F
- C26—.15 μ F
- C27—.2 μ F
- C28—.25 μ F
- C1-C11, electrolytics;
- C12-C28, tubular, 600 volts dc
- R1—470,000 ohms, 1/2 watt
- R2—100,000 ohms pot, audio taper with spst switch
- R3—220,000 ohms, 1/2 watt
- R4—15,000 ohms, 1/2 watt
- R5—4,700 ohms, 1/2 watt
- R6, R8—100 K, 1/2 watt
- R7—10,000 ohms, 1/2 watt
- R9—0.27 ohm, 2 watt
- R10—0.33 ohm, 2 watt
- R11—0.47 ohm, 2 watt
- R12—0.56 ohm, 2 watt
- R13—0.68 ohm, 2 watt
- R14—0.82 ohm, 2 watt
- R15—10 ohms
- R16—15 ohms
- R17—22 ohms
- R18—27 ohms
- R19—33 ohms
- R20—47 ohms
- R21—68 ohms
- R22—82 ohms
- R23—100 ohms
- R24—150 ohms
- R25—220 ohms
- R26—270 ohms
- R27—330 ohms
- R28—470 ohms
- R29—560 ohms
- R30—680 ohms
- R31—820 ohms
- R32—1,000 ohms
- R33—1,500 ohms
- R34—2,200 ohms
- R35—2,700 ohms
- R36—3,300 ohms
- R37—4,700 ohms
- R38—6,800 ohms
- R39—8,200 ohms
- R40—10,000 ohms
- R41—15,000 ohms
- R42—22,000 ohms
- R43—27,000 ohms
- R44—33,000 ohms
- R45—47,000 ohms
- R46—56,000 ohms
- R47—68,000 ohms
- R48—82,000 ohms
- R49—100,000 ohms
- R50—150,000 ohms
- R51—220K
- R52—270K
- R53—330K
- R54—470K
- R55—680K
- R56—820K
- R57—1 MEG
- R58—1.5 MEG
- R59—2.2 MEG
- R51—220,000 ohms, 1/2 watt
- D—1N34-A diode
- J1, J2—miniature plug (Amphenol 75-1 or equivalent)
- P1—prod for rf probe (General Cement 33-418 Klipzon Jumbo prod handle, black)
- Single-conductor shielded cable, 2 feet needed per probe
- Miniature alligator clips (2)
- Box—4 x 5 x 6-inch gray Hammertone aluminum utility box (Premier PMC-1007 or equivalent)
- Knobs—3 needed (2 for rotary switches, 1 for gain control)
- Speaker grille—2 1/2 x 2 1/2-inch aluminum screen

- R51—220,000 ohms
- R52—270,000 ohms
- R53—330,000 ohms
- R54—470,000 ohms
- R55—680,000 ohms
- R56—820,000 ohms
- R57—1 meg
- R58—1.5 meg
- R59—2.2 meg
- All resistors 1-watt carbon type, unless otherwise indicated.
- S1—spst switch, part of R2
- S2, S3, S4—spdt slide switch
- S5—sp3t slide switch
- S6—rotary switch, 3 poles, 17 positions, 3 decks (Centralab Type PA-3005)
- S7—rotary switch, 2 poles, 17 positions, 2 decks (Centralab Type PA-3003)
- J1—miniature connector, chassis mount (Amphenol Type 75-3)
- J2—closed circuit ear-phone jack
- J3, J5, J8—binding-post jacks (black)
- J4, J6, J7—binding-post jacks (red)
- BATT—9-volt battery
- LS—2 1/2-inch speaker
- T—transistor output transformer; 500-ohm pri, 3.2-ohm sec. (Lafayette Cat. No. 99 C 6123)
- Q1, Q2, Q3—2N107, Semitron AT10N or any low-cost small signal germanium type transistor
- Parts List for Probes
- C1—12 pF, disc ceramic
- C2—.002 μ F, disc ceramic
- C3—10 μ F, 25 volts, electrolytic (or .005 μ F, 500-volts—see text)
- R1—220,000 ohms, 1/2 watt
- D—1N34-A diode
- J1, J2—miniature plug (Amphenol 75-1 or equivalent)
- P1—prod for rf probe (General Cement 33-418 Klipzon Jumbo prod handle, black)
- Single-conductor shielded cable, 2 feet needed per probe
- Miniature alligator clips (2)
- Box—4 x 5 x 6-inch gray Hammertone aluminum utility box (Premier PMC-1007 or equivalent)
- Knobs—3 needed (2 for rotary switches, 1 for gain control)
- Speaker grille—2 1/2 x 2 1/2-inch aluminum screen

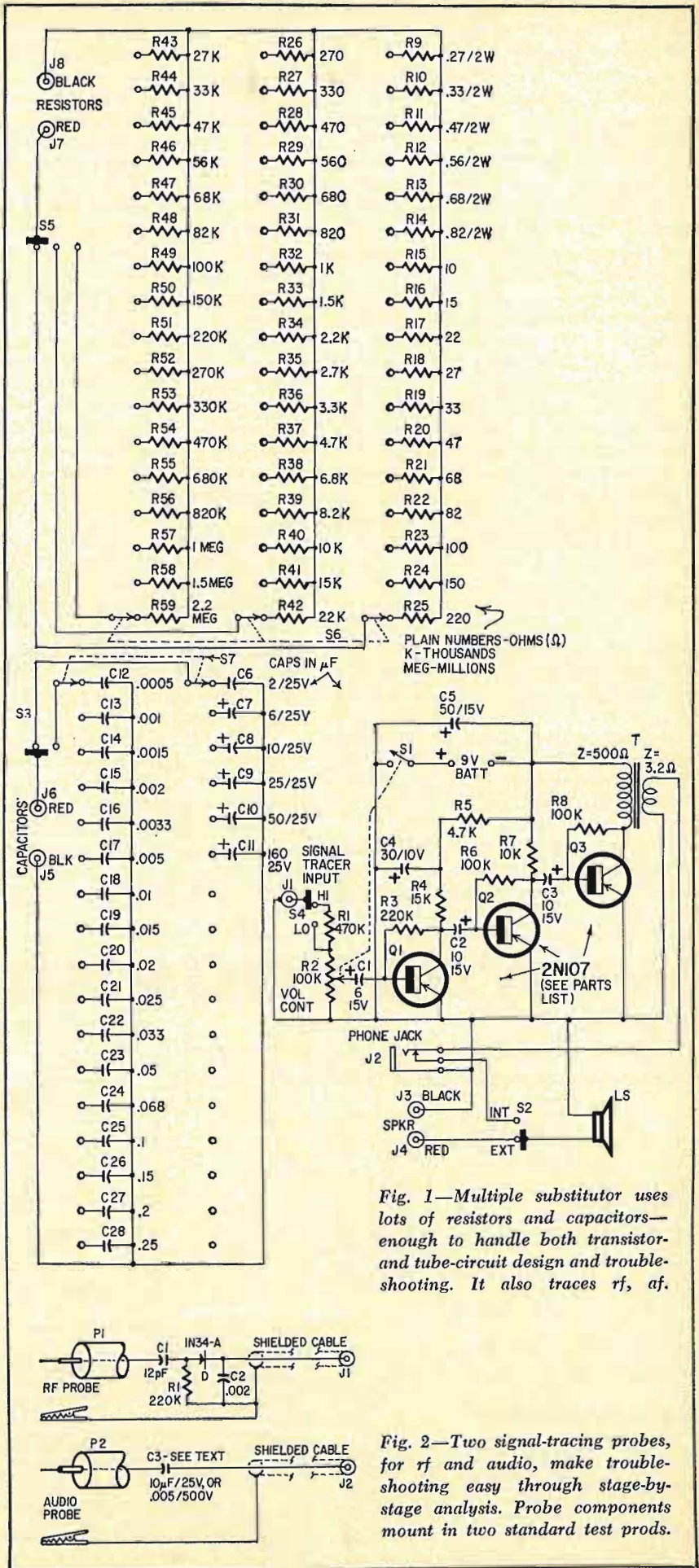

Fig. 1—Multiple substitutor uses lots of resistors and capacitors—enough to handle both transistor- and tube-circuit design and troubleshooting. It also traces rf, af.

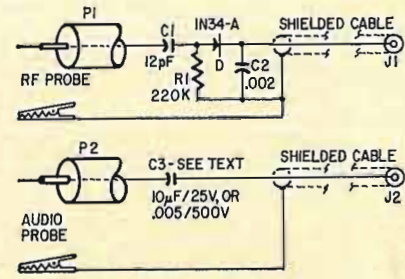

Fig. 2—Two signal-tracing probes, for rf and audio, make troubleshooting easy through stage-by-stage analysis. Probe components mount in two standard test prods.

beled HI and LO. There are 17 values from .0005 to .25 μF , in the LO range, all rated at 600 volts dc. There are 6 HI values, from 2 to 160 μF with dc working-voltage ratings of 25. These are ideally suited to the relatively low operating voltages used with transistors. There are switch facilities and space for up to 11 more values of your choice. You might want to add low-voltage 500- μF , 1,000- μF , and 2,000- μF units for power-supply filter and low-impedance audio decoupling tests.

In both the resistor and capacitor sections, terminations are through insulated jacks that accept banana plugs, tip plugs, spade lugs, and plain bare wire. Black-colored jacks identify the internal common connections for both resistors and capacitors. Red is the usual color for the other jacks. Separate jacks and switches for the resistor and capacitor sections make it possible to use them simultaneously for trying various combinations of R and C in a circuit.

Signal chaser

If you have worked with a signal tracer, you know how it saves troubleshooting time. A signal tracer is also useful when a piece of equipment is being breadboarded. The experimenter can test, stage by stage, a unit while it is being put together. What better place to put so useful a piece of test equipment than in your Sub Box? Naturally, this one is transistorized.

The signal tracer has more than enough power to drive the built-in $2\frac{1}{2}$ -inch speaker. Three high-gain transistor

stages are cascaded. The perforated phenolic board, with copper laminated on one side, measures only $1\frac{1}{8} \times 2\frac{1}{2}$ inches. It is mounted, after being wired, on 1-inch high spacers inside the box. A conventional 9-volt transistor-radio battery provides dc power. A simple clip formed from thin metal secures the battery to an inside wall of the box. The battery power switch is part of R2, the gain control for the signal tracer. A miniature phone jack disconnects the speaker automatically when a low-impedance earphone is used for close listening.

The tracer has sufficient gain to test phonograph cartridges, tape heads, and radio tuners simply by touching the audio probe and ground clip directly to the terminals of the part to be checked. With the rf probe, you can check the operation of rf and i.f. amplifiers, mixers, and discriminator stages of both radio and TV receivers.

The probes are easily assembled from standard components. The housings are conventional test prods with an inside diameter of approximately $7/16$ inch. The components fit neatly inside. Shielded single-conductor flexible cable connects the probes to the input of the signal tracer through miniature coaxial-type connectors.

Slide switch S4 at the input inserts or removes a series resistor to help prevent overdriving the input stage if a test signal is too high for the gain control of the tracer. The switch is labeled HI-LO, to correspond to high and low signal levels. The series resistor is in the circuit when the switch is at the HI position,

and reduces overall gain by about 13 dB.

If the probes will be used only in transistor circuits, the voltage ratings of the built-in capacitors can be low. Ratings of 15 volts should prove adequate. With high-power transistor audio amplifiers, the ratings have to be increased to 25 or 50 volts. With tube circuits, the ratings must be at least 500 volts. For tube work, the value in the audio probe can be reduced to .005 μF ; it should be 10 μF for transistors. If you expect to use the tracer for both, assemble a probe for each. The disc ceramic in the rf probe should have a 500-volt rating.

In use, the alligator clip at the end of the flexible, unshielded wire protruding from the prod should be attached to the common ground or chassis, near the circuit being checked. The tip of the prod is then touched to the high side of the circuit being checked.

A handy extra

A useful and easy-to-install addition to the Sub Box is slide switch S2 that transfers the voice coil of the speaker from the output of the signal tracer to a pair of jacks. The switch is labeled INT-EXT.

All sections of the Sub Box—the resistors, the capacitors, the signal tracer, and the speaker—can be used simultaneously. This one box can be the most valuable test instrument you own. When a new experimental project is started, or a receiver or other piece of equipment is to be serviced, the Sub Box may be the first test gadget you reach for . . . right after the soldering iron gets hot.

BND

WHAT'S YOUR EQ?

Conducted by E. D. CLARK

Black Box

In this circuit, the neon lamp glows momentarily each time the spring-return

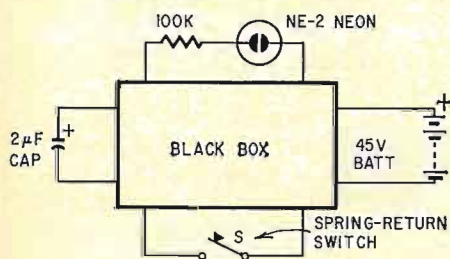

switch is depressed. What's the circuit inside the box?—John H. Gibson

Switching Circuit

Switches A, B and C (one spdt, two dpdt) control lights at their respective locations, so that one, but only one, is always lighted. Switch A turns light off at A and on at B; switch B turns off light at B and on at C, and so on.

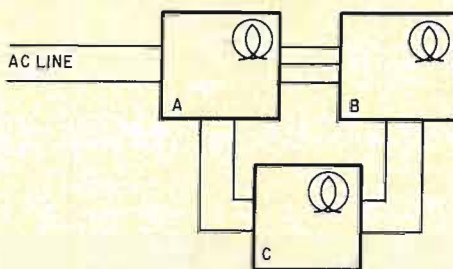

How are the switches wired?
—Albert S. Lombard

Two puzzlers for the student, theoretician and practical man. Simple? Double-check your answers before you say you've solved them. If you have an interesting or unusual puzzle (with an answer) send it to us. We will pay \$10 for each one accepted. We're especially interested in service stinkers or engineering stumpers on actual electronic equipment. We get so many letters we can't answer individual ones, but we'll print the more interesting solutions—ones the original authors never thought of.

Write EQ Editor, Radio-Electronics, 154 West 14th Street, New York, N. Y. 10011.

Answers to this month's puzzles are on page 95.

50 Years Ago

In Gernsback Publications
In December 1916
Electrical Experimenter

Transmitting Your Photo Over a Wire

Western Radio Amateurs Offer Their Stations to the Army

—Using the Armstrong Regenerative Audion System for Damped and Undamped Waves

Revolving Mirror for Determining Spark Characteristics

Anent the Audion
by Lee de Forest

Lights-On Reminder for Your Car

Daytime driving with your lights on may promote highway safety, but it's easy to leave them on when you park **By R. T. MONTAN'E**

DID YOU LEAVE YOUR PARKING LIGHTS ON? If you are not sure, here is a simple unit that keeps an eye on your lights for you. This Lights-On Reminder can be built with standard, readily available components for less than \$5.

Once you have installed it in your car, the Reminder will automatically tell you to turn off your lights if they are still on after you have turned off the ignition switch. A warning lamp lights and a buzzer sounds. If you don't like the buzzer, a switch on the rear of the chassis keeps it off but leaves the light working. In an emergency you can keep your lights on without the annoying sound. When the lights are turned off, the Reminder resets itself automatically.



One holding screw on unit is needed to secure assembly to the dashboard. For a fast connection to the wires under dash, use insulation-piercing alligator clips.

Circuit function

A simple spdt relay is the center of the device. Its principle of operation can be compared to a switching circuit in a computer. The relay in the circuit is de-energized and its contacts are closed when the ignition switch is off. If the lights are on, the lead from your dashboard lights or the taillights completes the circuit through the closed relay contacts to ground. The Reminder lamp and buzzer will alarm, and will continue until the lights are turned off.

If the ignition is turned on, the relay is energized and the contacts pull open. The Reminder's lamp-and-buzzer circuit is broken and the lights can be turned on without the unit alarming.

Voltage for the relay coil is taken from the car's fuse block or at any accessory circuit that is turned off with the ignition switch.

The installation is easy. All you need is a screwdriver to secure the Reminder under your dashboard. The lamp should be in view of the driver, although it is not necessary to keep it in view if the warning buzzer is kept on.

Attach the unit with a screw, nut and washer. Put the screw through from inside the chassis and then through the hole under the dashboard. Once the unit is in position, fasten the nut with the washer under it.

PARTS LIST

- RY—Dc relay, 2,300 ohms, 4.6 mA, spdt contacts (Sigma 11-F-2300-G/SIL or equiv)
- Buzzer—6-12 volts, ac-dc
- Lamp assembly—Bayonet socket with jewel, 7/16-in. mounting hole (Dialco 710-B or equivalent)
- Lamp—No. 53
- SW—spst slide switch
- Clips—Mueller 50C, or equivalent, with insulators
- Chassis—1 1/4 x 2 3/4 x 2 5/8 in. (Bud CB-1623 or equivalent)

The red lead goes to any accessory that is on the ignition switch. Some cars have an extra fuse position; if so, use it. If your fuse block is in the engine compartment, make the lead extra long. If the fuse block on your car is inaccessible, clip the lead to an accessory wire.

The black wire goes to any of the lamps on your dashboard that go on when the lights are turned on. If a dashboard lamp wire is not easily located, fasten the black wire to the wire that goes to your taillights. *Caution:* Don't connect the black wire to directional signals or brake lights.

It is good practice when doing electrical work on your car to disconnect the battery. This will eliminate the possibility of a short while you are working. Remove the hot terminal from the battery. Once you feel the Reminder is installed correctly and you have checked the hookup, reconnect the battery. **END**

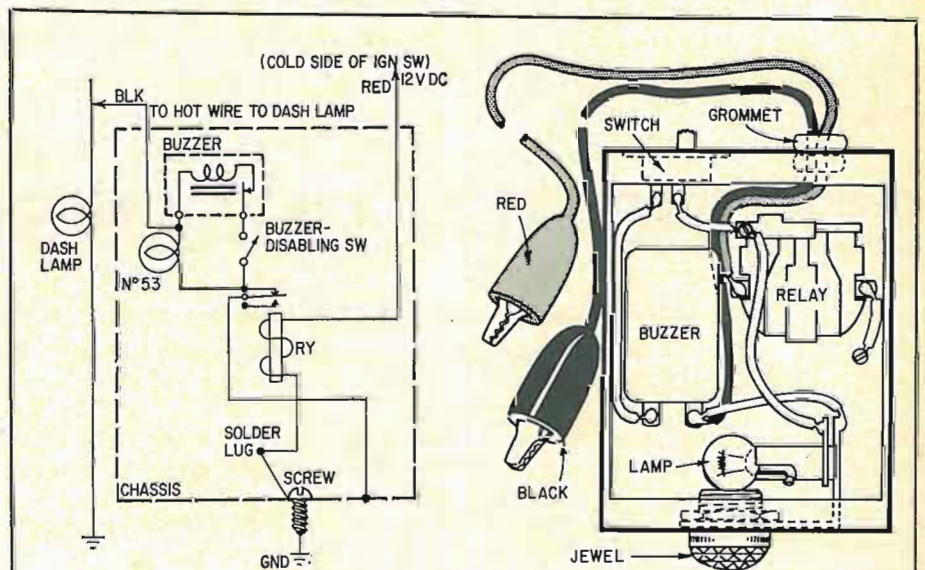

Fig. 1—Wiring should follow color code: red and black leads throughout. This reduces possible wiring errors.

Fig. 2—Wiring of unit is centered around circuit relay. Arm of the relay is grounded to the main support.

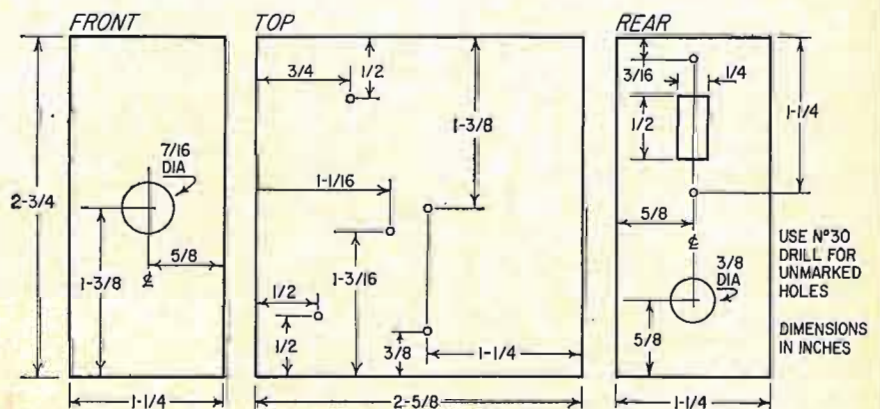
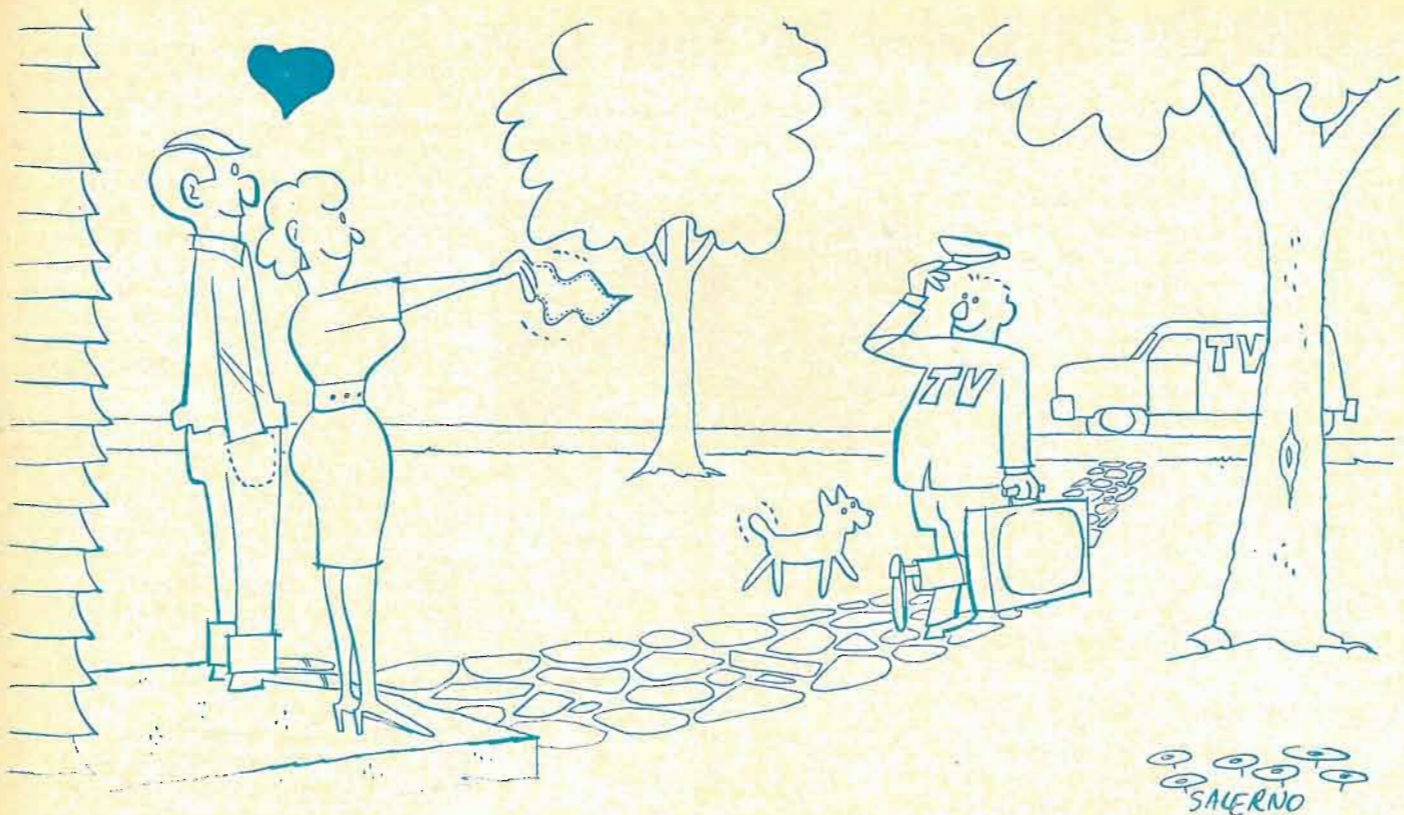

Fig. 3—Once all the holes have been located and center punched, drill each one through with a number 30 bit. Then drill out larger holes shown above.



SELLING THE CHASSIS OVERHAUL

It isn't always easy to get a customer to let you take the set to the shop. Here, an old pro tells you his "convincers" By ART MARGOLIS

ONCE YOU DECIDE, ON A HOUSE CALL, that the sick TV is best repaired in the shop, that's not the end of it. You must sell the idea to the set owner. You must convince him or her that your diagnosis is correct and you are the man to do the job.

To accomplish this sales feat, we've found, you need to hit four spots: (1) Your *technical explanation* of the trouble must ring true. (2) You have to stick your neck out with an *estimate of charges*. (3) You have to *promise a delivery date* and (4) *your company image must be correct*. Some case histories will illustrate what I mean.

The technical explanation

Explaining a TV trouble with all its nuances to a nontechnical set owner can present lots of problems. First of all, the reason why you are pulling the TV is because you don't know what's wrong and you want the troubleshooting environment of the bench. How do you tell a customer you don't know what's wrong?

Secondly, you want to give a convincing story but you don't want to give out too much information—you will be

held to every letter you utter. You must brief the customer in somewhat general terms.

Like a 17-inch Philco dual chassis model I was called to repair. It was owned by a doctor and he wanted all the details. The symptoms were agc. The local channels were washed out and the distant channels coming in better than usual. The doctor said, "What's the trouble?"

I said, "The symptoms suggest an agc condition." Meanwhile I checked tubes.

"Where is that circuit?"

I switched his "where" to "what." "An agc circuit is a brake on the signal. When the signal gets too strong, the agc, automatic gain control, brakes it and keeps it at a prescribed level."

He said, "Oh." He grasped the general meaning. Also he was fairly satisfied that I wasn't a rank beginner.

Tubes didn't help, so I pulled the chassis. On the bench I clipped a high-impedance bias box to the agc line. The picture cleared up except for some bending and a bit too much contrast.

When I install a bias box, if the picture clears up perfectly, it means to

me that the trouble is in the agc line. If it doesn't, the trouble is usually elsewhere.

One thing the box does, though, when the trouble is *not* in the agc line: it keeps correct plate voltages on the i.f. strip. When the box isn't in there, the i.f. plates can rise or fall according to the grid bias. This can give false indications of trouble. With the correct bias on the grids, provided by the bias box, any wrong plate voltages are indications of real trouble.

With the bias box in, I began reading plate voltages. All okay. I checked grid bias. All grids were supposed to be near zero or slightly minus. The grid of the second i.f. read plus 4. There was a 68-pF capacitor (Fig. 1) coupling the plate of the first i.f. to the grid of the second. I disconnected it at the grid end. Then I checked the voltage on the free lead. At first it was zero; then it gradually built up to about 5 volts. I replaced the capacitor. The agc condition cleared.

On delivery, the doctor wanted to know what had been wrong. I said, "A bad capacitor in the second i.f. stage."

He snorted, "I thought you said it was agc trouble."

"It was. The bad capacitor so overloaded the stage that the agc braking action didn't work. The agc circuit wouldn't perform till the signal path was clear."

He nodded and was satisfied. With general terms and analogies you can provide enough facts for even the cleverest set owner, not admit you didn't know precisely what component was bad, and not stick your foot in your mouth!

Formula for estimates

This is a sticky situation. As long as you are below your estimate or right on, there are no problems. But if you go over, you have one heck of a time explaining. There is a way to handle it, though. First, you have a good idea of what price you'd like to get for a particular job. If it's picture tube, tuner, sync or any other trouble you've had plenty of before, the diagnosis and repair time is not going to be too unusual.

Second, you don't have to hit on the nose. You can give a range. For instance \$18 to \$28, or \$40 to \$45. This people will buy. Third, add onto your estimate an "insurance" figure of a couple of dollars to cover the occasional job you goof on.

A typical job that turned out well after some touch-and-go moments was a 21-inch department-store special owned by a do-it-yourselfer. When I arrived I was informed that he had diagnosed by himself the fact that his picture tube was bad. He had purchased a new picture tube and it was sitting alongside the TV. He wanted me to install it for him.

I figured I'd better check his work. If I installed the tube and the TV still didn't work, I'd get the blame.

I turned on the TV. There was good high voltage at the CRT anode but no raster. The CRT heaters were lit. I tried the brightness control. No effect. All the rudimentary tests pointed to CRT but it didn't look right. I got my CRT tester and plugged it on the CRT neck. The meter read "EXCELLENT."

I told the gentleman that his diagnosis was close but not exact. There was other trouble. He mounted his high horse and insisted I replace the tube. I said I would if he'd pay whether the picture came back or not. He wavered and then asked sarcastically what I estimated the job would cost.

Since it wasn't the CRT, the bad component could be no more than a capacitor or control. Mentally I estimated our normal pickup, delivery and bench charges plus components. Then I added a \$5 insurance fee and quoted a price. He said, "If you made a mistake and it is the picture tube, will you do it for the same price?" I agreed.

On the bench I began taking CRT

socket voltage readings. On the cathode (pin 11) there was unwavering B-plus (Fig. 2). It was coming from the plate of the video amplifier. A 0.22- μ F capacitor at 600 volts had shorted to 10 ohms. I replaced it.

Confidently I turned on the TV. There was still no raster! I read the CRT cathode voltage. It was correct now. What was happening?

I installed my 8-inch test CRT. I breathed a sigh of relief: It had no raster either.

In about 15 minutes, after tracing out the high-voltage rectifier output part by part I found a 100,000-ohm resistor in the anode line that had increased

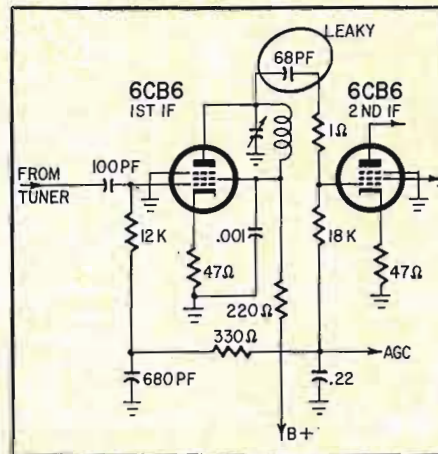

Fig. 1—Leaky coupling capacitor caused symptoms that looked like agc trouble.

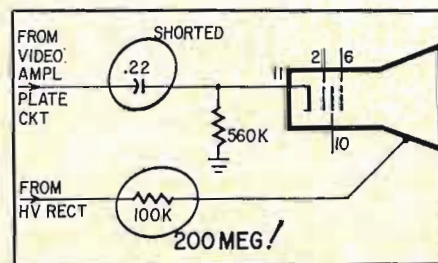

Fig. 2—These two bad components misled owner, who thought CRT was at fault.

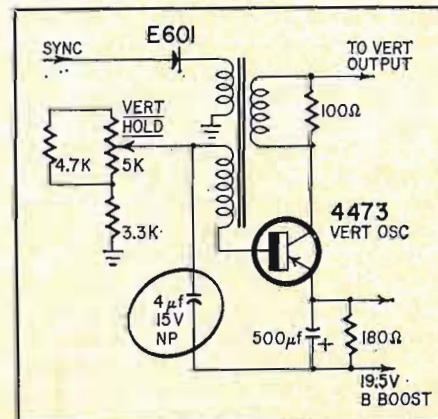

Fig. 3—Shorted nonpolarized electrolytic made vertical oscillator run off frequency.

to 200 megohms! I replaced it. The raster came on.

I returned the TV to an unhappy customer. But he was unhappy only with himself. Since I stuck precisely to the estimate range (the extra \$5 covered the resistor trouble), I was in a good chassis job and had gained the confidence of a new customer. Next time he'll probably call us before doing anything.

Delivery promises

The biggest complaint people have about chassis jobs is the length of time a TV is away from the house and they have to be without their daily TV "fix". You must promise a delivery date and then live up to it. If you don't, you'll lose more chassis jobs than you'll get.

Don't make ridiculously short delivery dates if you can't live up to them. It's better to promise a week and live up to it than promise one day and then deliver in 4 days.

I'm happy to report we repair all TV's as soon as they hit the shop. Not many repairs take more than an hour or two, so to play it safe we promise 48 hours except over the weekend, since we are closed on Sundays. But the 48-hour promise is on straight shop jobs. If there might be a parts holdup or an intermittent defect, we take that into consideration. Here is what we promise the set owner.

I was out servicing a Motorola transistor portable TV. The vertical frequency was running wild. Since there were no vertical oscillator or sync tubes to pull and replace, it simply had to be a shop job.

The customer was reluctant to let me take it. She said, "Last time it went out it was away a month."

Frankly, I was a little hesitant to promise her 48 hours. There aren't too many transistor jobs around and some of the parts take time to get.

I took a deep breath and explained, "Nine out of ten of our jobs are completed from pickup to delivery in 48 hours. One out of ten takes longer because of a hard-to-get part or a particularly sticky trouble. I don't want to promise you anything I can't live up to, but, due to the nature of your trouble, odds are good you won't fall into the one-out-of-ten category."

Vertical roll troubles are usually small component problems. I figured I was safe in what I said.

Actually the set owner has no choice. It's either let you take it, call somebody else to take it or not fix it.

As most people do, she shrugged her shoulders and said, "OK, take it."

On the bench I eagerly pulled the TV apart since we don't get many of these. No tubes, but under the chassis, the components looked familiar.

I found the vertical oscillator transistor. Then I began testing the most likely suspects, starting with the transistor. The third one, a 4- μ F 15-volt electrolytic (Fig. 3), was open. I replaced it. The trouble was gone.

The TV was returned the next day. The customer was very pleased.

Postscript to the story happened about 8 months later. The TV was dropped and landed on its tuner. All the coils and wafers were punched out. A new tuner was ordered. It took 3 weeks to get. The set owner didn't even whimper and was still pleased when we finally returned the TV.

Company image

This is more subtle, but you must recognize its importance and the advantage of a good one.

People here in the USA are educated (or brainwashed, whatever you want to call it) to worship brand names and a seemingly efficient, uniformed organization.

If you can get your customers to feel that you use brand-name replacement parts, that you are qualified by reason of many certificates, diplomas, etc., and you yourself are an exemplary individual, you have created an image that's hard to refuse shop jobs to. The job is sold almost automatically. The customer will agree to whatever you suggest.

A typical example of the awe in which people hold brand names was a

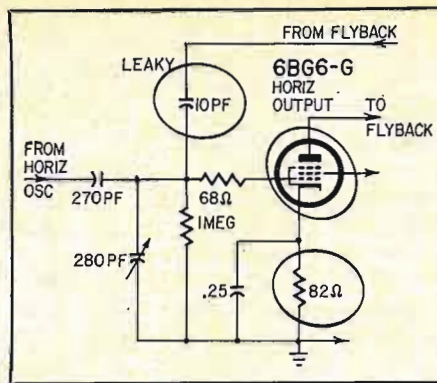

Fig. 4—Leaky flyback feedback capacitor put +13 volts on horizontal output grid.

16-inch Brunswick model 8125 I recently serviced.

The customer was really anxious. He opened the truck door for me and grabbed my tube caddy. Meanwhile, he looked the truck over very thoroughly. Then he led me to a lush den where the TV was.

As I opened the tube caddy I watched his face. He was pleased with the neat, colorful array. I turned on the TV. The 6BG6 horizontal output tube was arcing internally. I put in a new tube. It too began to arc. I said, "The set has problems."

He answered, "You're the doctor. Do what you have to do."

"It should be taken into the shop so we . . ."

"It's your baby," he interrupted.

"Wouldn't you like to . . ."

"Whatever you say goes, fella."

I shrugged and pulled the chassis.

At the shop I pulled the 6BG6 out of the socket and turned on the TV. Then I took voltage readings. The screen grid read 175 volts as it should. The control grid read 13. It was supposed to read -30.

I disconnected the two grid input capacitors (Fig. 4). One came from the horizontal oscillator. The other came from a winding in the flyback. I turned the set back on and took a voltage reading at the capacitors' free ends. The oscillator coupling capacitor read zero. The 10-pF capacitor from the flyback read +13.

I replaced the leaky 10-pF and the +13 disappeared. I also replaced the 68-ohm grid resistor, the 82-ohm cathode resistor and the 6BG6—all showed signs of wear. The set came back to normal.

On delivery, after I installed the chassis I started to write up the bill. The set owner said, "Don't bother. Just give me the total and I'll write you a check."

This guy was too good to be true. He continued, "After all, you're the Brunswick TV man."

"Who told you that?" I asked.

"I saw your Brunswick equipment in the truck."

I kept quiet even after I realized what gave him that impression. In the truck I have a Brunswick bag that holds my bowling ball. END

Removing the Mystery from Matching

How does tube or transistor impedance affect speaker performance?

By NORMAN H. CROWHURST

PRECEDING ARTICLES (SEE REFERENCES) dealt with the difference that three governing values—maximum power, minimum distortion and maximum gain—can make in the choice of optimum load for a triode, pentode or transistor. All these are concerned with the effect the load value has on these parameters of the tube or transistor operation. The fourth parameter, which we take up here, reverses the viewpoint; it is concerned with how the resistance or impedance of the tube or transistor affects the load—usually a speaker.

The previous articles explained what damping does to the performance of a speaker. By feeding it with a voltage derived from a source with very little internal resistance, any tendency of the speaker to overshoot or behave erratically is damped by the short-circuiting effect of the low internal resistance.

Because a low internal resistance provides better speaker damping than a high one, the ratio between load and

source resistance has been called *damping factor*. If a 16-ohm speaker is fed from a source of 2 ohms, the damping factor is 16 divided by 2, or 8.

Hence, this aspect of matching has to provide good damping. While arranging that the load of a 16-ohm loudspeaker provides the optimum load (assume 4,000 ohms) required in the plate circuit of a tube, the circuit must also see to it that the 16-ohm loudspeaker is fed from a source impedance, or resistance, of 1 ohm.

A transformer transforms impedances both ways (Fig. 1). If 16 ohms reflects through the transformer to look like 4,000 ohms (250 times the actual value), the plate resistance of the tube must also be transformed down by 250:1. If it is to look like 1 ohm, its value at the primary must be 250 ohms.

Even a triode tube does not have that low a plate resistance, if its optimum load is 4,000 ohms. So the *effective* plate resistance is adjusted to the desired value by *feedback*. Now we've got

feedback, as well as simple matching ratio, into the matching picture.

Let's take the example of a typical output pentode, feeding its normal "optimum load." Assume that, without feedback, the plate resistance at the operating point is 10 times the required load impedance. At one extremity—the "knee" of the pentode curves (Fig. 2)—the plate resistance drops to twice load impedance. At the other extremity of the load line, the plate resistance (represented by the slope of the plate current/voltage curves) rises to 100 times load impedance. The average is about 10 times.

Gain, as well as resistance, changes. Notice the spacing between points where the load line crosses the curves. They are fairly uniform, except for the lowest space, which is only about half the width of the others. This means the gain of the tube drops to about half the value throughout the rest of the waveform, when the grid swing drives it down to that end.

Because the average plate resistance is 10 times load impedance, removing the load would cause a rise in output voltage of 11 times (assuming the input level is low enough to allow that much rise without saturating the tube).

Now let's assume feedback is applied, enough to reduce gain by 6 dB with the load connected. To find what this does to impedances, we have to consider the *circuit* impedance at different points on the waveform.

At the operating point, the total shunt impedance is $\frac{1}{11}$ (about 0.91) of the load impedance; 6 dB feedback will reduce this to half— $\frac{5}{11}$ of the load impedance. This means the source impedance part of this will be $\frac{5}{6}$ of load impedance; hence the damping factor at the operating point is 1.2.

At the limit of positive grid excursion, the total shunt impedance is $\frac{2}{3}$ of load impedance; 6 dB feedback will reduce this to $\frac{1}{3}$, which means the source impedance part will be half the load impedance. The damping factor at this point is therefore 2.

At the other limit of output waveform excursion, the total shunt impedance is $\frac{100}{100+1} = 100/101$ of the load

impedance. But the gain is reduced to half. This results in a damping factor of 0.515.

So, throughout a high-amplitude output waveform, the damping factor of a pentode loaded with the correct optimum load resistance changes from 2 to 0.515.

Apart from the fact that such fluctuation of damping factor could cause serious IM distortion when higher frequencies are present at the same time, we have looked at things from the viewpoint of the load, which we have been regarding as fixed.

Assuming a resistor (dummy load), rather than a speaker, the load is a *fixed* value. Even so, from the tube's viewpoint, waveform changes modify grid drive, due to resultant changes in feedback. This is equivalent to changing a voltage, or making the loading vary at different points on the waveform. If it's that complicated with a dummy load, think (but don't imagine too hard) what speaker impedance can do!

Multiple operation

Multiple output matching can best be understood by referring to a matching transformer. (The principle, of course, is not by any means restricted to matching transformers.) Some examples will illustrate typical possibilities.

First, assume we have a transformer designed to work from an 8,000-ohm plate-to-plate load, with 4-, 8- and 16-ohm taps on the secondary (Fig. 3). This means that connecting any one

load of 4, 8 or 16 ohms to its appropriate tap will reflect an impedance of 8,000 ohms plate to plate (Figs. 3-a and b).

Now, if we want to feed two 16-ohm speakers in parallel we'll connect them to the 8-ohm tap (Fig. 3-c), because that's what their parallel value is. Correspondingly, but slightly less obviously, to share power equally between a 16-ohm and an 8-ohm speaker, we would connect the 16-ohm to the 8-ohm tap and the 8-ohm to the 4-ohm tap (Fig. 3-d).

From this example, you see that the reflected load impedance is the combined effect of all the secondary loadings in parallel. One doesn't just connect all 16-ohm speakers directly to the 16-ohm tap. That would be right only for one 16-ohm speaker, working by itself. When the 16-ohm speaker is connected to the 8-ohm tap and the 8-ohm speaker to the 4-ohm tap, both receive power

and are thus in parallel for the transformer.

If we connect a 16- and an 8-ohm speaker in parallel (Fig. 4-a), the 8-ohm unit receives twice as much power as the 16-ohm unit, because it takes twice the current at the same voltage. Now suppose we want one of two 12-

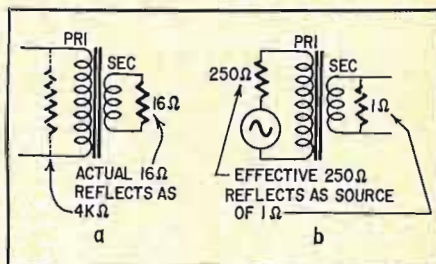

Fig. 1—An output transformer transforms impedances two ways. a—It makes 16-ohm load look like 4,000 ohms to tube plate. b—It makes plate resistance of 250 ohms look like 1 ohm to the loudspeaker.

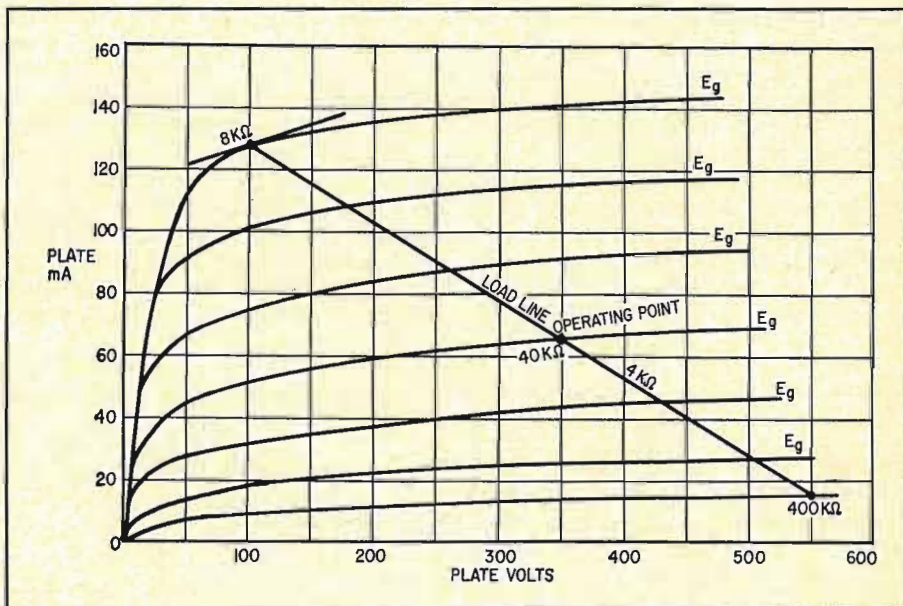

Fig. 2—Operating plate voltage and current curves taken from a single-ended pentode, used to illustrate effects of impedance and gain relations at different points along the load line. A feedback signal, when used, will drastically alter the effect of the damping factor under the conditions described above, as explained in text.

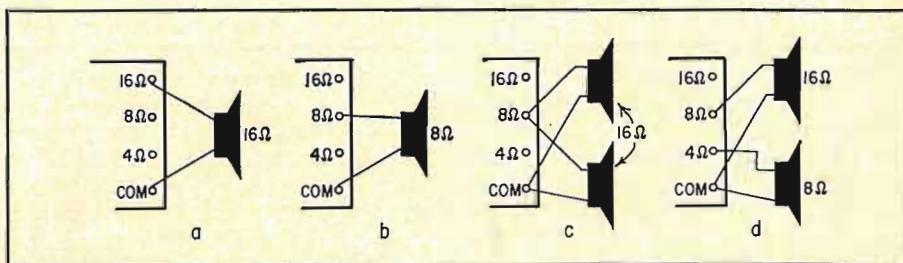

Fig. 3—Division of power between multiple loads: a, b—A single 16- or 8-ohm loudspeaker connects directly to its appropriate output tap. c—Two 16-ohm units are in parallel on the 8-ohm tap. d—A 16-ohm and an 8-ohm unit each connect to a tap with half of their respective impedance ratings. Although it seems incorrect, such connections are necessary in order for both speakers to share the power equally.

ohm loudspeakers to receive twice the power the other does.

This is readily accomplished by connecting one to the 8-ohm and one to the 4-ohm tap (Fig. 4). The 12-ohm unit connected to the 4-ohm tap gets $\frac{1}{3}$ the power a 4-ohm unit would, while the 12-ohm unit connected to the 8-ohm tap gets $\frac{2}{3}$ the power an 8-ohm unit would. Each connected only to its nominally correct tap would get all the power. But with this connection, the unit connected to the 8-ohm tap gets $\frac{2}{3}$ and the one connected to the 4-ohm gets $\frac{1}{3}$ of the total power, which is what we wanted.

This is not an article on speaker power distribution, so we won't get into any more complicated instances. The next example of multiple matching concerns the class of operation of the tubes or transistors.

First, assume we have a transformer output-loaded as before. If two tubes require a plate load of 4,000 ohms each, working in class A, the total load is 8,000 ohms plate to plate. Actually the impedance at each plate is 2,000 ohms, $\frac{1}{4}$ the total winding, because the impedance ratio equals the turns ratio squared. But in class A, both tubes deliver power together, so they each feed half the power to the output load, which we'll take as 16 ohms.

Half the power, with a common voltage, means half the current, so each tube actually drives the equivalent of 32 ohms on the 16-ohm tap. Each plate "sees" twice the "nominal" impedance of 2,000 ohms for the half primary, or

4,000 ohms. Working it out either way, the matching is right.

Now assume we are working class B. Each tube feeds all the power for half the cycle. So now each plate gets a load of 2,000 ohms, *during its operating half-cycle*.

While this means that the same matching ratio can usually be used for different classes of operation with the same tubes, it does not mean the same transformer will do. The class-B transformer must be specially designed so it can perform this "switching" from one plate to the other between half-cycles without producing any spurious effects, like "notch distortion."

The third example of multiple matching concerns ultralinear operation and, more properly, bridging connections. In describing how ultralinear circuits work, the term *screen loading* is often used. Numbers are given, derived in a way similar to those for impedance taps on the transformer.

For example, the popular screen-tapping point for many tubes is at 43% of the primary turns, measured from the center tap toward each plate (Fig. 5). For convenience, we will take 40%, which is $\frac{2}{5}$. If this tapping were used as the primary connection, instead of the plate tapping, the reflected impedance would be $\frac{4}{25}$ ($\frac{2}{5}$ squared) of the rating for the plate connections. The fraction $\frac{4}{25}$ represents 16%. Using a 43% *voltage* tap is equivalent to an 18½% *impedance* tap. This has sometimes been referred to as 18½% screen

loading—meaning impedance.

Assuming the secondary is correctly loaded, the impedance measured at each plate would be, say, 2,000 ohms. That measured at the screen taps would be $\frac{4}{25}$ of this, or 320 ohms (370 ohms for 18½%). *But this does not mean the screens are loaded with 320 or 370 ohms.* The fluctuations in voltage and current to the screens may contribute a very small part of the output power from an ultralinear circuit—probably 1% or 2%. But this is not the basis of its operation.

The ultralinear circuit produces its particular effect because the *voltage* applied to the screen affects plate current to a much greater degree than does voltage applied to the plate. The small change in screen current, flowing through a small proportion of the transformer's turns, contributes very little to the output, and nothing to making it more linear.

Really, the screen connection in an ultralinear circuit is a form of *bridging* connection. A bridging input, for example, normally has an impedance of at least 10 times that of the circuit into which it is connected. Consider the broadcast and recording-studio practice of using a matched 600-ohm line between one amplifier's output and another's input (Fig. 6). (This is done particularly when the amplifiers are several hundred or more feet apart.) The line amplifier's output is designed to be loaded with 600 ohms, while the other amplifier's input is designed to provide that load of 600 ohms. Additionally, to monitor the transmission level, a VU meter is often connected, at either or both ends. Such a meter has an impedance of 6,000 ohms or more, to produce a minimum of extra loading on the line amplifier. The VU meter is "bridging" the line.

In ultralinear operation, the flow of audio power is in the opposite direction, *from* the screens *to* the transformer; but the operation of the circuit occurs in its particular manner because of the voltage applied *to* the screen by the transformer.

Thus, matching isn't as mysterious as is often thought. Like a window, a transformer works both ways. While a tube or transistor is looking at a speaker and seeing a certain impedance, that same speaker is looking back through the transformer and seeing the tube or transistor's impedance. Each affects the other.

END

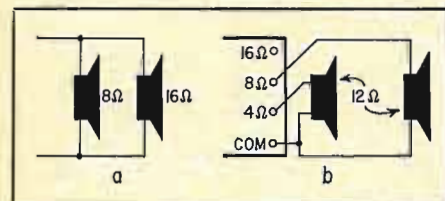

Fig. 4—Two ways of feeding unequal levels of power to loudspeakers: a—Speakers with unequal impedances are connected to taps with same impedance. b—Speakers of like impedance are connected to taps having unlike impedances, splitting power.

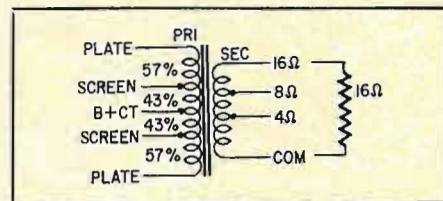

Fig. 5—Ultralinear output transformer discussed in text. Percentages marked on primary relate to turns, not impedance. Numbers by secondary taps indicate impedance load for which they are intended. Effect of screen voltage is key to operation.

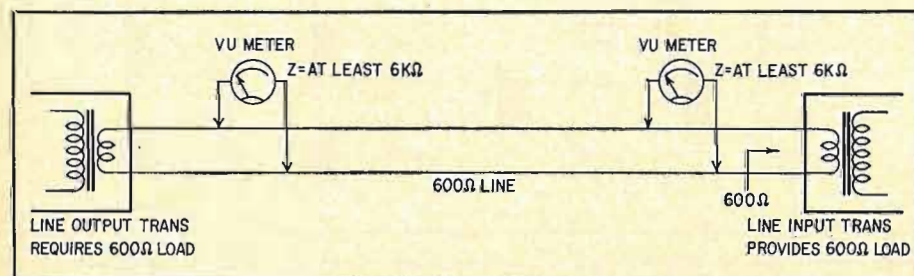

Fig. 6—Bridging connections applied to a line. Input to the line-terminating amplifier provides 600-ohm load required by the output of the amplifier feeding the line. The VU meters monitoring line level have an impedance of 6,000 ohms or more.

References (all by Norman H. Crowhurst in following issues of RADIO-ELECTRONICS)

1. "Applying Variable Damping," July 1957.
2. "Tube Data and Amplifier Design," November, December 1957.
3. "Is the Output Transformer Out?" January 1958.
4. "Using Audio Transformers," April 1960.

Versatile Tester for Transistors

This simple-to-build matcher and evaluator will tell you much about transistor operation

By DON ANGLIN

WHAT WOULD YOU CALL AN IDEAL transistor checker? One that will check gain and leakage? Will not damage low-voltage or low-current devices? Will classify transistors by type (npn or pnp) and is easy to operate? All this at a reasonable price? Sound like a tall order? This tester does the job admirably. Read on and decide for yourself.

Probably the most useful leakage measurement, and the one shown on most specification sheets, is I_{CBO} . This is the collector-to-base leakage with the emitter open-circuited, and is measured by the circuit shown in Fig. 1-a. I_{CBO} varies from a few nanoamperes in high-quality silicon planar transistors to many microamperes in low-cost germanium units. Measuring I_{CBO} directly would need an expensive multirange, low-current meter. But I_{CBO} can be measured indirectly, at a lower cost, by measuring I_{CEO} .

Fig. 1-b shows the basic circuit for measuring I_{CEO} (collector-to-emitter leakage current with base open). Since I_{CEO} is the product of I_{CBO} times beta (the current gain of the transistor), it is a larger current and can be measured on an inexpensive 0-1 milliammeter. We can find I_{CBO} by dividing the I_{CEO} reading by beta, which this checker will also measure.

A high I_{CEO} reading does not necessarily indicate an excessively leaky transistor. It could mean that the transistor has normal leakage and a high beta. Germanium transistors generally have more leakage than silicon transistors, and experience has shown that if I_{CEO} is more than 0.5 mA the transistor is not usable in most circuits. Germanium power transistors normally have an I_{CEO} greater than 1 mA, and cannot be tested on this checker.

Transistor current gain or beta (β) is defined as a change in collector current (ΔI_C) caused by a change in base current (ΔI_B) with the collector-to-emitter voltage remaining constant. Most transistor checkers, even some expensive ones, do not hold V_{CE} constant while making beta measurements. The formula for beta is:

$$\beta = \frac{\Delta I_C}{\Delta I_B}$$

with ΔV_{CE} (change of collector-to-

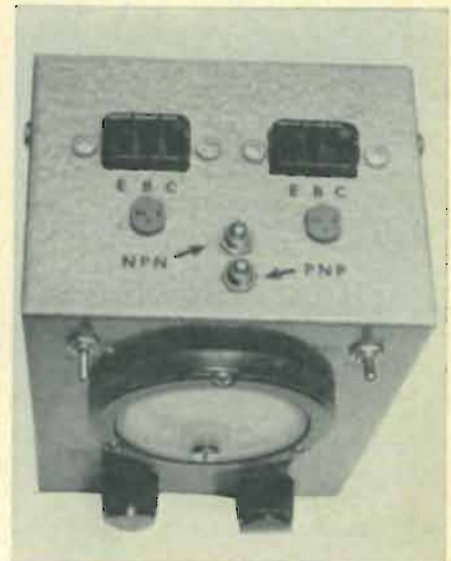

Front and top views of the completed tester. Black sockets on top are for testing transistors with long leads. The smaller sockets are used for plug-in units. Sockets are wired in pairs.

emitter voltage) equal to zero.

There are two current-gain parameters, both commonly called beta. The first is *dc* or large-signal, current gain (h_{FE}), which is the ratio of the collector current to the base current causing it. The second is small-signal, or *ac*, current gain, which we'll take up in just a moment. Fig. 2 shows the basic circuit used in the checker for measuring h_{FE} . The Zener diode holds V_{CE} constant (one of the basic requirements for beta measurement) and holds the voltage used to supply I_B constant for the life of the battery.

The accuracy of the beta reading is directly proportional to the stability

of the voltage source used to supply the base current. Without Zener regulation, the tester would be accurate only with a new battery with full output voltage and low internal impedance. With the Zener, accuracy is maintained as long as the battery can supply sufficient current to keep the Zener in the regulating portion of its curve.

Note that before you press the pushbutton, the circuit in Fig. 2 is the same as that in Fig. 1-b, and reads I_{CEO} . When the pushbutton is pressed, base current will flow in the transistor. This current is equal to the Zener voltage divided by the base resistor R_B . If R_B is made such that I_B is 1/100 of the full-

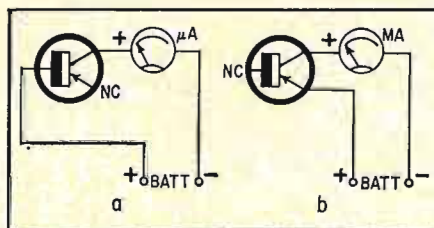

Fig. 1-a—Collector-to-base leakage circuit; b—Collector-to-emitter leakage test circuit, which uses the transistor under test to amplify the leakage current. Since small current is amplified, meter need not be as sensitive as the one used in circuit (a).

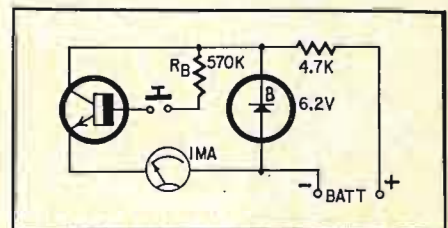
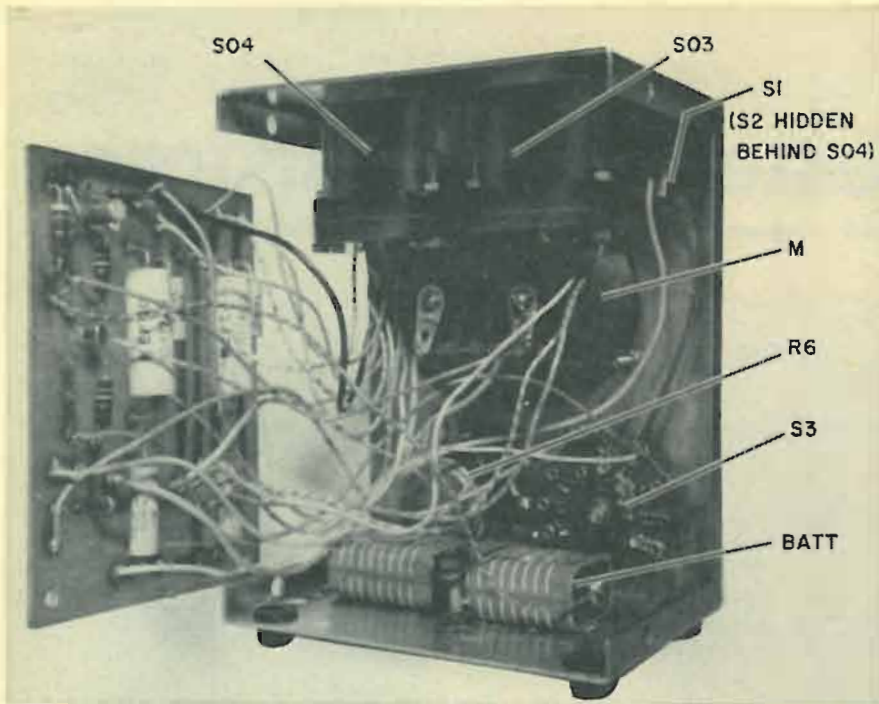

Fig. 2—Dc-beta measuring circuit. For accuracy in readings, it is important that the collector-to-emitter voltage be held constant; hence the Zener diode is used to regulate power supply output. Value of R_B is changed for various transistors under test.



All components except panel devices and battery were assembled on etched circuit board. Any other kind of wiring is equally suitable. Exact wire lengths are unimportant.

scale meter sensitivity, then the meter will read betas of 0-100 directly. Since many transistors have gains greater than 100, switch-selected resistors are used for R_B in the checker to get ranges of 0-100 and 0-1,000. Other ranges, such as 0-250 or 0-500, would be useful, but would require interpolation of meter readings or adding new calibrations to the meter face.

For greatest accuracy, R_B should be a precision resistor, and the Zener voltage (V_Z) should be measured. The Zener may be any 400-mW unit rated 5 to 6 volts. The 1N429 was chosen because it was available cheaply on the surplus market. It is rated 5.9 to 6.5 volts; the one I used measured 6.2 volts. When you calculate the value of R_B , subtract the V_{BE} of the transistor-under-test (TUT) from V_Z . Since V_{BE} is normally 0.3V for germanium and 0.7V

for silicon transistors, I used a compromise of 0.5V for calculations. The value of R_B comes from the formula $R_B = (V_Z - 0.5)/I_B$. If you use a 1-mA meter, $I_B = 10 \mu A$ for the 0-100 range and $I_B = 1 \mu A$ for the 0-1,000 range.

The meter reading in the dc-beta measuring circuit is I_{CEO} plus the collector current caused by the base current applied through the pushbutton. I_{CEO} must be subtracted from the meter reading for an accurate beta measurement, especially if it is an appreciable part of the total current. As an example, if a transistor being tested has an I_{CEO} of 0.1 mA and the meter reads 0.6 mA on the 0-100 scale, the change in collector current caused by the base current is $0.6 - 0.1 = 0.5$ mA, which corresponds to a beta of 50. The same reading in the 0-1,000 scale would indi-

cate the transistor has a beta of 500.

Ac beta

Small-signal current gain (h_{fe}) is the ratio of the change in the transistor collector current caused by a small change in base current, and is commonly called ac beta. It's normally measured with a 1,000-Hz audio signal, but the circuit in Fig. 3 will give a close approximation. Zener diode D1 holds V_{CE} constant, and Zeners D1 and D2 are legs of a bridge and hold the voltage at point A constant. The voltage at point B is essentially constant, varying from that of point A only by the small drop across the meter. The other legs of the bridge consists of R1 and the transistor being tested. Before you make the gain test, the bridge must be balanced by injecting enough current into the base of the transistor with the ZERO control to cause the transistor's impedance to equal R1. This sets the operating point for the transistor and cancels out all leakages so that the meter reading during testing indicates beta without the need for subtracting leakage current as we did in Fig. 2.

Since the voltage at point B is constant, the voltage across R1 and the current through R1 are constant. Any change in the transistor current will flow through the meter and D2. Therefore, the change in collector current caused by the base current injected when the TEST button is pressed can be read on the meter as AC BETA. The maximum collector current is about 2.5 mA, low enough not to damage low-current transistors.

If the I_C vs I_B curves for all transistors were linear (gain the same at all collector currents) then dc beta and ac beta would be equal. The curve for the ideal transistor is curve A in Fig. 4. The earlier silicon transistors and almost all power transistors have characteristics more like curve B. These transistors will have a low dc-beta reading and a higher ac-beta reading. They would be suitable for circuits where the average collector current is 1 mA or more. This includes most small-signal amplifiers, except micropower circuits and low-noise amplifiers. The tester does not supply enough collector current to get power transistors into the normal operating part of their curves, and both beta readings will be misleading. For this reason, this checker is for small-signal transistors only.

Curve C is typical for transistors designed for micropower circuits, and dc beta will be higher than ac beta. After checking the transistor at two points on the curve, you can determine its suitability for a particular application.

Fig. 5 shows the complete transistor-checker schematic. It is a combination of the test circuits of Fig. 2 and 3.

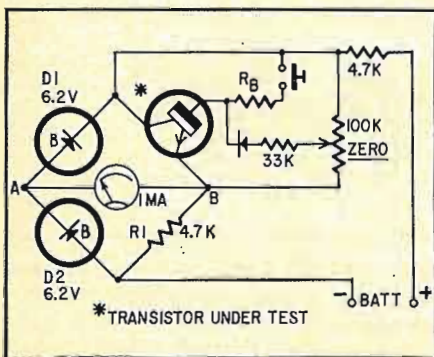

Fig. 3—Ac-beta measuring circuit uses a bridge circuit to null out collector current.

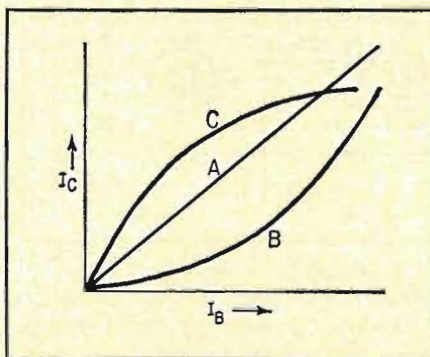

Fig. 4—Curves of collector current vs base current for three different transistor types.

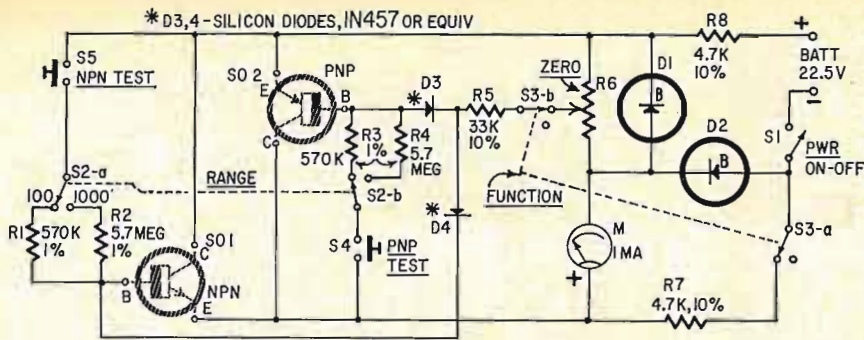

Fig. 5—Schematic of the complete tester, after developing it from Figs. 2 and 3.

BATT—22½-volt battery
 D1, D2—1N429 Zener diode, or similar (5.9-6.2-volt 400-mW diodes)
 D3, D4—Silicon diodes, 1N457 or equivalent
 M—1-mA meter movement
 R1, R3—570,000 ohms, 1%
 R2, R4—5.7 megohms, 1%
 Note: These are not standard 1% values. You can select them from 560,000-ohm and 5.6-meg 5% or 10% resistors by checking on an accurate bridge, or connect in series one 560,000- and one 10,000-ohm 1% resistors (standard Aerovox values), or one 562,000- and one 8,060-ohm 1% resistors (standard from most manufacturers). A similar series connection of 5.6-meg and 100K, or 5.62-meg and 8.06K can

be used to make 5.7 megohms.
 R5—33,000 ohms, 10%
 R6—pot, linear, 100,000 ohms
 R7, R8—4,700 ohms, 10%
 All resistors ½ watt
 S1—spst toggle switch
 S2—dpdt rotary switch
 S3—dpst toggle switch
 S4, S5—normally open pushbuttons (ganged spst pushbuttons OK—see text)
 SO1, SO2—4-terminal transistor sockets (see Fig. 6) (Elco 05-3301 or equivalent)
 3 x 4 x 5-inch chassis or 2-piece box
 Knobs and miscellaneous hardware
 SO3, SO4—deep well transistor test sockets (Pomona TS-187 or equivalent.)

Layout is not critical, but watch battery and diode polarities. The checker was built in a 3 x 5 x 4-inch two-piece aluminum box. All components not mounted on the panel can be on a small printed circuit type of board. S4 and S5 can be ganged, if you can find ganged spst pushbuttons. Separate miniature switches were used in the original tester. S4 is for testing pnp transistors, and S5 for npn transistors.

Combination sockets are wired as shown in Fig. 6 so that each socket will accept either in-line or diamond-lead transistors. Transistor test sockets such as Pomona model TS-187 are handy for checking transistors with long leads. They can be flush-mounted with long screws and wired in parallel with SO1 and SO2.

If you know the "sex" of the transistor (nnp or pnp), insert it in the appropriate socket. Set the function switch to the I_{CEO}/DC position, turn power switch S1 ON, and read I_{CEO} . A reading greater than 1 mA indicates that the transistor is shorted or leaky. To measure dc beta, set range switch S2 to the 0-100 position and press the TEST button (S4 or S5), read the meter, and subtract the I_{CEO} reading to get dc beta. If the meter reads more full scale, beta is greater than 100. Then set S2 to 0-1000, press S4 or S5 and read beta. On this range, $\beta = (I_T - I_{CEO}) \times 1,000$, where I_T is the total current read on the meter. If there is no leakage or beta reading, the transistor is open.

To read ac beta, set the function switch to the ZERO/AC position and balance the bridge by adjusting ZERO po-

tentiometer R6 for a zero reading on the meter. If the bridge cannot be balanced, the transistor is shorted, open or excessively leaky. Now press S4 or S5 to read ac beta.

If you don't know the type, insert the transistor into the pnp socket and set S3 to the I_{CEO}/DC position. If you can check gain and leakage, the transistor is a pnp. If you get no meter reading, test the transistor in the npn socket. If there is no reading in either socket, the transistor is open. A full-scale reading in both sockets indicates a shorted transistor. You will not damage a transistor by testing it in the wrong socket. The power switch should be OFF except when making checks, because the current drawn by the Zeners will run the battery down.

Additional uses

The checker may be used to test small npnp devices for blocking and turn-on capability. Insert the SCS or SCR in the npn socket, which is wired correctly for most of them, with anode lead to the collector terminal, gate to base and cathode to emitter. Set S3 to the I_{CEO}/DC position. There should be no reading on the meter because the SCR will be blocked or "off" with 6

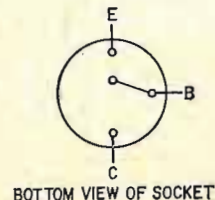

Fig. 6—How to wire four-terminal transistor sockets for in-line and diamond-pattern of transistor base-lead use.

volts on its anode. The meter will read full scale when the SCR fires. With S2 in the 0-1,000 position, press TEST button S5. This injects $1 \mu A$ into the gate and will turn on only the most sensitive SCR's. Then set S2 to 0-1,000 and press S5. Since we are injecting $10 \mu A$ now, many SCR's such as 2N1595 and 2N2323 will turn on. Because the supply is dc, the SCR will remain on even though S5 is released. The SCR can be turned off by momentarily removing it from the socket or turning the power switch off.

If $10 \mu A$ will not trigger the SCR, switch to the ZERO/AC position. The ZERO control can be used to inject from zero to $300 \mu A$ into the gate for turn-on. By setting the gate current just under the turn-on current with the zero control, the SCR can be turned on by the additional $10 \mu A$ added when S5 is pressed. The checker will not test SCR's requiring more than $300\text{-}\mu A$ gate current to fire. END

STATEMENT OF OWNERSHIP, MANAGEMENT AND CIRCULATION. Required by the Act of October 23, 1962, Section 4369, Title 39 United States Code. Radio-Electronics, published monthly at 10 Ferry Street, Concord, Merrimack County, New Hampshire 03302. The General Business offices of the Publisher are located at 154 West 14 St., New York City.

1. The names and addresses of the publisher, editor and managing editor are: Publisher, M. Harvey Gernsback, 154 West 14 St., New York City; Editor, Forest H. Belt, 154 West 14 St., New York City; Managing Editor, none.

2. The owner is: Gernsback Publications, Inc.; 154 West 14 St., New York City; Hugo Gernsback, 154 West 14 St., New York City; M. Harvey Gernsback, 154 West 14 St., New York City.

3. Known bondholders, mortgagees, and other security holders owning or holding 1 percent or more of total amount of bonds, mortgages or other securities: None.

4. The above paragraphs include, in cases where the stockholder or security holder appears upon the books of the company as trustee or in any other fiduciary relation, the name of the person or corporation for whom such trustee is acting, also the statements in the two paragraphs show the affiant's full knowledge and belief as to the circumstances and conditions under which stockholders and security holders who do not appear upon the books of the company as trustees, hold stock and securities in a capacity other than that of a bona fide owner. Names and addresses of individuals who are stockholders of a corporation which itself is a stockholder or holder of bonds, mortgages or other securities of the publishing corporation have been included in the above paragraphs when the interests of such individuals are equivalent to 1 percent or more of the total amount of the stock or securities of the publishing corporation.

5. The average number of copies each issue during the preceding 12 months are: (a) Total number copies printed (net press run): 220,281; (B) Paid circulation: (1) To term subscribers by mail, carrier delivery or by other means: 102,962; (2) Sales through agents, news dealers, or otherwise: 58,059; (C) Total paid circulation: 161,021; (D) Free distribution: 2,146; (E) Total number of copies distributed: 163,167; (F) Office use, leftover, unaccounted, spoiled after printing: 57,114. The number of copies single issue nearest to filing date are: (A) Total number copies printed (net press run): 222,714; (B) Paid circulation: (1) To term subscribers by mail, carrier delivery or by other means: 106,215; (2) Sales through agents, news dealers, or otherwise: 56,110; (C) Total paid circulation: 162,325; (D) Free distribution: 2,304; (E) Total number of copies distributed: 164,629; (F) Office use, leftover, unaccounted, spoiled after printing: 58,085.

I certify that the statements made by me above are correct and complete.
 (Signed) M. Harvey Gernsback
 Publisher

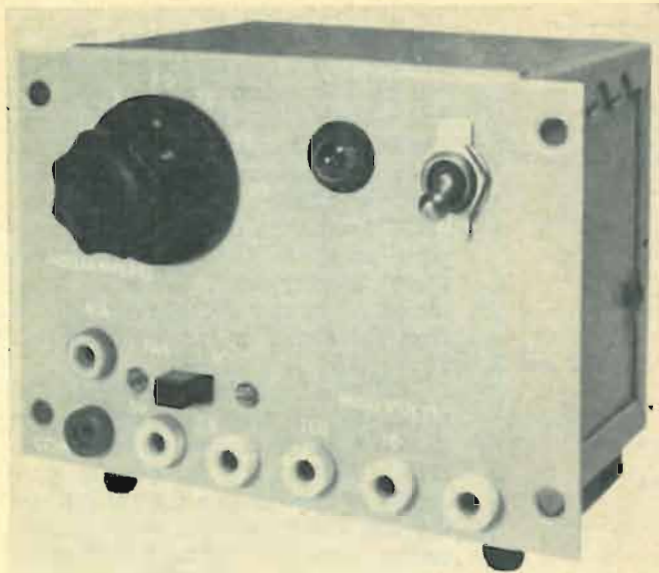

Self-contained current source offers great versatility, practical panel arrangement. Duplicating unit should offer no problems.

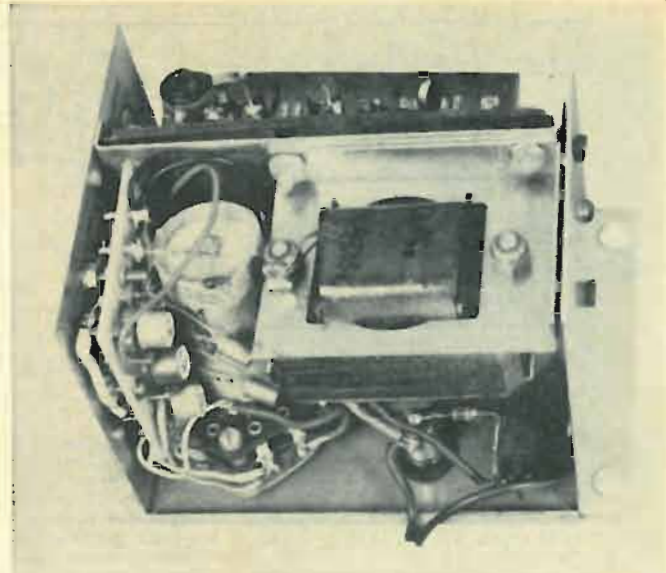

Interior arrangement is neat, with basic components mounted on PC board, current-determining resistors on the strip at top.

A Low-Cost Constant-Current Source

Remarkable control and regulation of current from 1 to 20 mA despite severe voltage fluctuations characterizes this device **By CLEMENT S. PEPPER**

MOST TECHNICIANS AND EXPERIMENTERS are familiar with the regulated power supply which maintains a constant output voltage, even though the load current may fluctuate over a broad range. Less familiar is the constant-current source, the current-supplying equivalent of the regulated voltage supply. Current through the load is held at a constant level, even though the load voltage fluctuates over a wide range.

Current sources are much more common in transistor technology than in equivalent vacuum-tube applications, and are easily constructed. The vacuum-tube circuit is cumbersome and requires high operating voltages. In industrial equipment, constant-current sources can be found in a variety of applications—oscillator, sweep-generator, differential-amplifier and similar circuits which require unusually good stability.

A constant-current source is also a handy thing to have on the bench for measuring diode and Zener characteristics and for conducting experiments with timing circuits, relaxation oscillators, linear sweeps, battery charging and transistor testing.

What is a current source?

When we refer to a "current source" we mean a circuit possessing a high internal impedance with respect to the load. In this sense, a 1-megohm resistor is a current source to a 1,000-ohm

resistor. Shorting the load changes the current by only 0.1%. On the other hand, if you double the battery voltage you double the current, too; so something more is needed.

The circuit described and illustrat-

ed here (Fig. 1) is not affected by short circuits. Current output remains constant over a wide range of resistances; a two-to-one change in input voltage has practically no effect whatever, provided reasonable voltage lim-

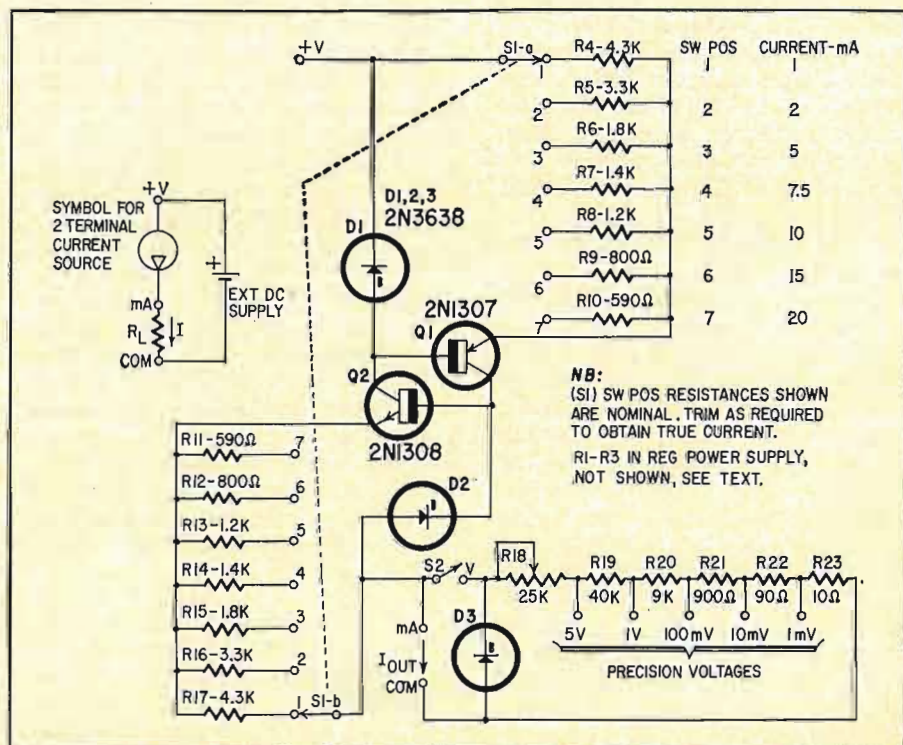

Fig. 1—Constant-current circuit employs diode-connected transistors instead of actual Zeners for current regulation. Precision voltage circuit permits calibration of vtvm's.

its are not exceeded. What's more, the circuit is cheap, compact, and contains no critical parts.

Most of the space inside the box is taken up by a built-in regulated dc supply, which was added only because it was simple and cheap, too. The regulated supply isn't necessary; you can, in fact, drive the source using raw dc from a half-wave rectifier and a small filter capacitor. As an example, I drove a 10-mA cascaded current source using 30 volts dc obtained from a half-wave rectifier and 50- μ F capacitor.

The dc reference voltages were added to perform a variety of tasks around the lab. The values chosen were judged to be best for meter calibration and as signal voltages for dc-amplifier measurements. Accuracy depends on the quality of resistors used and the care taken in calibration. Low-value resistors are used in the millivolt range to provide a low source resistance for the dc amplifier under test to look into. Dc amplifiers frequently are sensitive to large source resistances.

The current source is connected into a circuit just like a diode; as with a diode, proper polarities must be observed. The primary characteristic of the device is that it will provide a constant current for any voltage drop across the circuit within its upper and lower limits of input voltage. The load may present any resistance without affecting the current. If the supply voltage or the load resistance changes, the change in voltage is absorbed by the current source. Let's see how this can be.

In Fig. 2, we have the equivalent circuit of a transistor in the common-emitter configuration. The circle with the arrow ($i_b\beta$) is the symbol of an ideal current generator, the task of which is to supply a fixed current into any load. This current generator is controlled by the base current (i_b) and the current gain (β or beta) of the transistor. There is a resistance (r_d) in parallel with the current generator. If r_d were not there, all collector current (i_c) would be drawn from the generator, and i_c would be determined solely by the base current and the current gain ($i_b\beta$). Because r_d is present, however, the collector current is partially dependent on the collector-to-emitter voltage (V_{ce}). Resistance r_d is not an actual resistor, of course, and its value is dependent on circuit operating conditions and transistor current gain. In the common-base configuration, for example, it may be 10 megohms or more. In a common-emitter circuit, the common-base value is divided by the transistor current gain; if you use a high-beta transistor, r_d will be smaller—as low as 10,000 ohms in some cases. Germanium transistors exhibit far lower values of r_d than do silicon types. By cas-

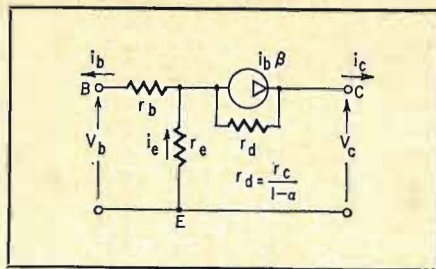

Fig. 2—Equivalent circuit of common-emitter transistor circuit, with parameters.

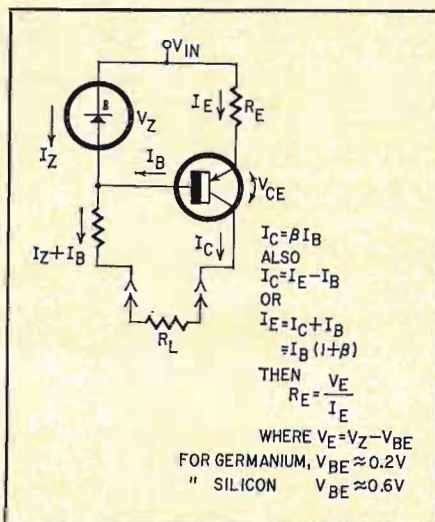

Fig. 3—The basic form of solid-state constant-current circuit stabilized by a Zener.

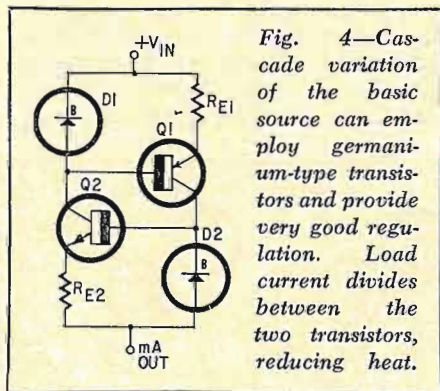

Fig. 4—Cascade variation of the basic source can employ germanium-type transistors and provide very good regulation. Load current divides between the two transistors, reducing heat.

cading two current sources, however, a very "stiff" current source can be obtained with germanium transistors.

The basic constant-current circuit is shown in Fig. 3. The highly regulated collector current in this circuit is made possible by emitter resistor R_E and the Zener diode in the base circuit, and here's why. We have a fixed voltage (V_Z) connected to the base. The internal resistance of the Zener diode is very low, so variations in base current, including leakage current, will not affect the voltage at the base. Inside the

transistor is a voltage drop across the base-emitter diode; in a typical germanium transistor, about 0.2 volt. If Zener voltage V_Z is 6, then 5.8 volts would appear across emitter resistor R_E .

To calculate the value of R_E that will result in the desired regulated current (equal to I_C), divide emitter voltage V_E by the desired current value ($R_E = V_E/I$). The value for I actually is emitter current I_E ; since I_E approximately equals I_C , however, the equation will give satisfactory accuracy. (Note that $I_E = I_B + I_C$, and $I_C = \beta I_B$. If $\beta = 100$, then I_C is only 1% less than I_E .)

For better accuracy than that, it will be necessary to place an accurate milliammeter in the collector circuit and carefully select the exact resistance for R_E that will give the required current value. Because of tolerances allowed for V_Z , V_{BE} , and R_E , you must follow the latter procedure if you want a really precise current.

While the basic source described has many applications, the cascaded circuit shown in Fig. 4 has distinct advantages. For one thing, it is very stiff; that is, the current remains constant over a very wide range of operating conditions. Also, current is divided between two transistors, so twice the load current can be obtained for the same transistor dissipation. The complementary transistor combination is somewhat self-regulating as well, so improved stability with temperature changes and internal transistor parameter drift is obtained. Last, but not least, you can use cheap germanium transistors—even unmarked surplus. The circuit shown in Fig. 1 is a more versatile version of the cascaded source.

The minimum value of V_{in} is determined mostly by the Zener voltages. For the 6-volt diodes used in these circuits, V_{in} must be greater than 12 volts. The maximum voltage is determined by the transistor-collector ratings. Lower-voltage Zeners are available and can be used, but the emitter resistors will then have to be recalculated. Since a 6-volt Zener diode has just about the lowest internal resistance of any, it represents a good choice. A lower-voltage Zener requires a smaller value for R_E , which reduces the transistor-current stability quite directly.

Actually, both reasons given are part of the same stability factor for a transistor circuit. Maximum stability results when the base looks into a short circuit and the emitter into a very large resistance. Another consideration is cost. You can buy three 2N3638 transistors for the price of one 1N753 Zener diode, for example. Measurements I have made indicate that the transistor actually makes a better Zener diode for this application.

**ALL POPULAR
ELECTRONIC
COMPONENTS...**

**AVAILABLE
AT DISTRIBUTORS
EVERYWHERE**

**ONE-SOURCE
FOR YOUR COMPONENT NEEDS**



**ERIE'S
EXCITING NEW
ELECTRONIC
COMPONENTS
STATION**

COMPONENTS
IN HANDY, EASY TO
IDENTIFY PACKAGES
AT DISTRIBUTORS
Everywhere!

- CERAMIC DISC CAPACITORS!**
Voltages—12 V. thru 1000 V
Capacitance—5 pF thru 220,000 pF (22 uF)
- CERAMIC TUBULAR CAPACITORS!**
Voltages—100 V and 500 V
Capacitance—1 pF thru 1000 pF
- MYLAR FILM CAPACITORS!**
Voltages—200 V thru 600 V
Capacitance—.01 uF thru .1 uF
- TRIMMER CAPACITORS (Variable)!**
Ceramic - Plastic - Glass
Ranges to suit your needs
- RECTIFIERS & DIODES!**
Industry's Most Popular Types

**IF
AN ERIE
STATION
IS NOT AT
YOUR
DISTRIBUTOR
CLIP AND MAIL
COUPON
TODAY!**



ERIE TECHNOLOGICAL PRODUCTS, INC.
Attn: Distributor Sales
Erie, Pennsylvania

YOUR NAME _____
 ADDRESS _____
 CITY _____ STATE _____
 NAME OF YOUR FAVORITE DISTRIBUTOR ... _____
 ADDRESS _____
 CITY _____ STATE _____

TABLE 1—Zener Characteristics of Silicon Transistors

TRANSISTOR NUMBER	1 mA	2 mA	5 mA	7.5 mA	10 mA	15 mA	20 mA	CONSTRUCTION
2N327A	5.85	6.00	6.20	6.25	6.32	6.37	6.40	P—Alloy
2N328A	5.90	6.05	6.25	6.30	6.33	6.37	6.40	P—Alloy
2N332 (1)	2.14	2.41	2.90	3.10	3.24	3.43	3.55	N—Grown
2N332 (2)	3.40	3.73	4.10	4.20	4.27	4.38	4.44	N—Grown
2N336 (1)	6.35	6.38	6.40	6.41	6.45	6.50	6.55	N—Grown
2N336 (2)	7.70	7.75	7.80	7.85	7.90	7.95	8.00	N—Grown
2N338	3.50	3.75	4.05	4.20	4.30	4.40	4.50	N—Grown
2N696	5.85	6.03	6.21	6.27	6.33	6.36	6.39	N } Diffused
2N697	5.90	6.02	6.23	6.27	6.33	6.35	6.38	N } planar
2N1132	5.90	6.00	6.20	6.30	6.33	6.35	6.38	P—Diff. planar
2N1613 (1)	11.00	11.15	11.25	11.30	11.35	11.40	11.45	N } Diffused
2N1613 (2)	9.80	9.85	10.00	10.05	10.10	10.15	10.25	N } planar
2N1711	9.60	9.60	9.65	9.70	9.75	9.78	9.80	N—Diff. planar
2N3565 (1)	11.20	11.23	11.27	11.29	11.32	11.35	11.39	N—Diff. planar
2N3565 (2)	10.20	10.22	10.28	10.31	10.33	11.37	10.41	
2N3638 (1)	5.90	5.93	5.99	6.02	6.05	6.09	6.12	P—Diffused planar epitaxial
2N3638 (2)	6.00	6.04	6.10	6.14	6.16	6.21	6.24	
2N3638A (1)	6.00	6.02	6.06	6.09	6.12	6.16	6.19	
2N3638A (2)	5.90	5.92	5.95	5.98	6.00	6.04	6.07	
2N3640	5.10	5.15	5.24	5.32	5.37	5.45	5.53	N—Pl. epitaxial
2N3643 (1)	7.00	7.05	7.11	7.15	7.18	7.23	7.25	N } Pl. epitaxial
2N3643 (2)	6.40	6.43	6.48	6.51	6.53	6.57	6.61	
2N3704 (1)	6.90	6.92	6.96	6.99	7.01	7.05	7.09	N } Planar
2N3704 (2)	7.00	7.03	7.06	7.09	7.11	7.15	7.18	
2N3711 (1)	11.40	—	—	—	—	—	11.80	N } Planar
2N3711 (2)	13.20	—	—	—	—	—	13.80	

ZENER DIODES	4.50	4.85	5.30	5.50	5.60	5.70	5.75
1N752	4.50	5.10	5.30	5.50	5.60	5.70	5.75
CD3138	5.00	5.10	5.30	5.35	5.40	5.45	5.50

NOTES: (1) and (2) indicate upper and lower voltages of a group of transistors. "P" and "N" indicate pnp and npn respectively. The 1N752 and CD3138 are Zener diodes included for comparison.

After you have assembled your current source, connect it to a variable-dc supply in series with a milliammeter. Increase the voltage while watching the current meter. As the voltage comes up to about 12, the meter will lock to whatever current you have selected. As the voltage continues up, the current will hold constant until you approach the upper voltage limit, at which time it will start to increase slightly. This will tell you the operating voltage limits. If you do not have a variable-dc supply, play it safe and never

exceed about 20 to 25 volts across the input and output terminals.

Zener substitutes

Zener diodes have many uses in modern transistor circuits, but they are expensive. It occurred to me that the base-emitter diode of a transistor might make a good Zener diode—most silicon-transistor specs show a low breakdown voltage. The hunch turned out to be a good one. I've made measurements on a wide assortment of silicon transistors and found almost every type useful. A tabulation (Table 1) is included here for a number of transistors. The transistor may have a shorted or leaky collector diode—or even an emitter-collector short—and still be useful as a Zener. So, never throw away a silicon transistor without first checking it for Zener voltage.

Now you can pay for your current source with the money you save in Zener diodes. The current source is the best thing to use when checking a Zener, because the Zener voltage is dependent to a certain extent on the current. This varies widely between types and, to a lesser extent, between units of the same type. The same technique also is useful for measuring the voltage drop across any diode—silicon or germanium—for a given current. Current-vs-voltage curves are quickly constructed this way.

Fig. 5 shows additional uses for the constant-current source of Fig. 1. With just a little experience in using the device, many more such applications undoubtedly will come to mind. END

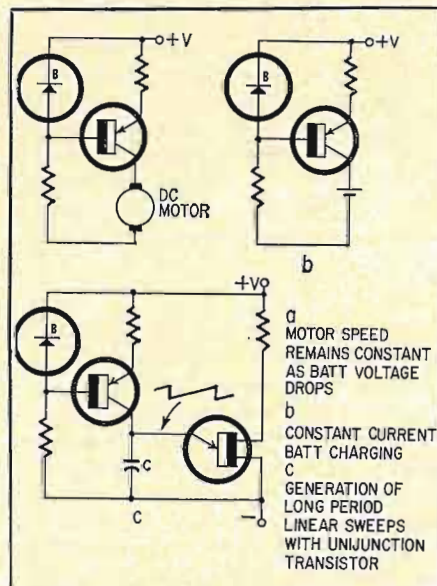

Fig. 5—Three useful applications of the constant-current source may suggest other possible uses for this versatile device.

FINCO[®]-AXIAL

COLOR-KIT



FINCO-AXIAL COLOR-KIT, Model 7512 AB

High performance Indoor and Outdoor Matching Transformers convert old-fashioned and inefficient 300 ohm hook-ups to the new Finco-Axial 75 ohm color reception system.

List price for complete kit . . .
7512AB \$8.95

7512-A Mast mounted matching transformer . . . list \$5.40

7512-B TV Set mounted matching transformer . . . list \$4.15

FINCO-AXIAL SHIELDED COLOR CABLE, CX Series

Highest quality, 75 ohm swept coaxial cable (RG 59/U) complete with Type F fittings, weather boot ready for installation.

Available in 25, 50, 75 and 100 foot lengths. List price . . . \$5.55, \$8.65, \$11.50 and \$14.20.

Write for Color Brochure # 20-349

**the
complete
color TV
reception
system**

For the best color TV picture

*eliminates color-fade, ghosting and smearing!
Improves FM and Stereo, too!*

QUICK, EASY INSTALLATION

ENJOY brilliant "TV-Studio" color reception today by changing over to the new Finco-Axial Color Reception System. NOW, color fade, ghosts and smears are a thing of the past. Finco-Axial shields color sets against signal loss . . . eliminates outside interference and mismatch problems.

THE FINNEY COMPANY 34 WEST INTERSTATE STREET, DEPT. RE BEDFORD, OHIO

Circle 27 on reader's service card

Build One Of These Famous HARMONY-By-HEATHKIT® Guitars In One Evening—No Woodworking! ... Build The New HEATHKIT® Guitar Amplifier In 8-10 Hours! Save Up To \$279!

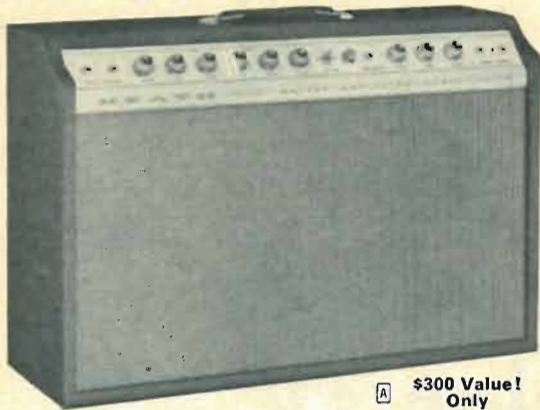

A \$300 Value!
Only
\$129⁹⁵



B \$329.50 Value!
Only
\$219⁹⁵



C \$158.50 Value!
Only
\$119⁹⁵

D \$145 Value!
Only
\$99⁹⁵



No Special Skills Or Knowledge Needed
Now you can save up to \$109.55 on a famous American-made Harmony electric guitar — plus another \$170 on the new Heathkit transistor guitar amplifier — by assembling them yourself the easy Heathkit way.

And all you need are some ordinary tools and a few spare-time hours . . . no technical skills or knowledge are required. The famous Heathkit instructions (so simple a child can understand) and giant pictorials guide you every step of the way. Nothing is left to chance.

You'll have your guitar kit finished in one evening. To give you a head start, all the wood parts are preassembled, finished and buffed at the Harmony factory. You just mount the trim parts, pickups and controls in the pre-drilled holes and install the strings. All woodworking and mechanical parts guaranteed a full year.

Each guitar kit includes a handsome chipboard carrying case with plush lining, instruction book, tuning record, pick, connecting cord, and a cushioned leather neck strap.

The guitar amplifier kit will probably take you a couple of evenings. Only one small circuit board to wire (don't worry about soldering, the Heathkit manual shows you exactly how), plus a few parts to mount on the chassis, and two speakers, controls and switches to install. The cabinet is already prebuilt and finished. It's easy fun.

Full Details FREE — Liberal Credit Terms
Compare the features of each kit. For complete details, plus information on the convenient Heath Time-Payment plan send for the FREE Heathkit Catalog. Simply write Heath Company, Benton Harbor, Michigan 49022.

A Deluxe Transistor Guitar Amplifier Kit . . . All The Features Guitarists Want Most. • 60 watts peak power — maximum power from Fail-Safe output circuit • Two channels — one for accompaniment, accordion, organ or mike, — the other for special effects with both variable reverb and tremolo • 2 inputs per channel • Two foot switches for hands-free control of tremolo & reverb • Two special design 12" heavy-duty speakers • Line bypass reversing switch for hum reduction • 28" W x 9" D x 19" H leather-textured black vinyl cabinet of 3/4" stock • Extruded aluminum front panel
Kit TA-16, 44 lbs. . . Save \$170. . . Only \$129.95

B Deluxe Hollow Body Electric Guitar . . . Three Golden Tone Pickups . . . Flat Wound Strings • Double-cutaway style for easy fingering of all frets • Ultra-slim fingerboard—24 1/2" scale • Ultra-slim, "uniform-feel" neck with adjustable Torque-Lok reinforcing rod • 3 pickups with individually adjustable pole-pieces under each string for emphasis and balance • 3 silent switches select 7 pickup combinations • 6 controls for tone and volume •

Professional Bigsby vibrato tail-piece • Curly maple arched body with "F" holes — 2" rim — shaded cherry red • Engraved headpiece, matching pick guard
Kit TG-46, 17 lbs. . . Save \$109.55. . . Only \$219.95

C "Rocket" Hollow Body Electric Guitar . . . Two Golden Tone Pickups • Single cut-away style for easy fingering • Ultra-slim fingerboard . . . 24 1/2" scale for easy chording • Ultra-slim neck, Torque-Lok steel rod reinforced • 2 pickups with individually adjustable pole-pieces for each string • Silent switch selects 3 combinations of pickups • 4 controls for tone and volume • Harmony type "W" vibrato tailpiece • Laminated maple Ultra-thin arched body with "F" holes, 2" rim, shaded cherry red • White plastic pick guard
Kit TG-36, 16 lbs. . . Save \$38.55. . . Only \$119.95

D "Silhouette" Solid-Body Electric Guitar . . . Two Golden Tone Pickups . . . Modern Design • Modified double cutaway leaves 15 frets clear of body for playing comfort and ease • Ultra-slim fingerboard of black rosewood — 24 1/2" scale • Ultra-slim neck for "uniform feel" • Torque-Lok adjustable reinforcing rod • 2 pickups with individually adjustable pole-pieces under each string • 4 controls for tone and volume • Harmony type "W" vibrato tailpiece • 6-in-line tuning keys • Hardwood solid-body, 1 1/2" rim, shaded cherry red • Extra large pick guard
Kit TG-26, 13 lbs. . . Save \$45. Only \$99.95

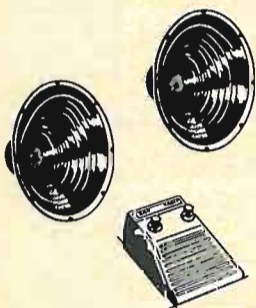

Deluxe Guitar Amplifier Features . . . two 12" heavy-duty ceramic magnet speakers, specially designed to project 60 watts of peak power . . . one easy-to-build circuit board with 13 transistors, 6 diodes for simple 8-10 hour assembly and cool, instant operation . . . heavy die-cast foot-switch for hands-free control of reverb and tremolo; housed in heavy die-cast zinc to prevent shifting while in use.

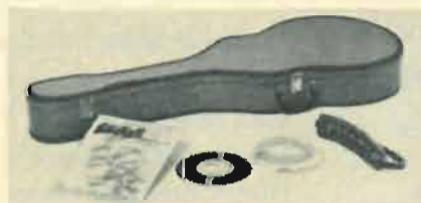

Included With Each Guitar Kit . . . instruction book, vinylized chipboard carrying case, tuning record, pick, connecting cord, and deluxe red leather cushioned neck strap.



Individually Adjustable Pole-Pieces under each string, on each pickup, permit the most critical adjustment for emphasis and balance. Allows you to balance volume of all strings, or to accent any string.

Turn Page For More New Kits From HEATH

Circle 28 on reader's service card

Regardless Of What You Pay For A 19" Color TV... It Can't Perform As Well As This New Heathkit® "180" For Only \$379⁹⁵*



Here's Why!

Exclusive Features That Can't Be Bought In Ready-Made Sets At Any Price!

All color TV sets require periodic convergence and color purity adjustments. This new Heathkit GR-180 has exclusive built-in servicing aids so you can perform these adjustments anytime . . . without calling in a TV serviceman . . . without any special skills or knowledge. Just flip a switch on the built-in dot generator and a dot pattern appears on the screen. Simple-to-follow instructions and detailed color photos in the GR-180 manual show you exactly what to look for, what to do and how to do it.

Results? Beautifully clean and sharp color pictures day in and day out . . . and up to \$200 savings in service calls throughout the life of your set. No other brand of color TV has this money-saving self-servicing feature!



Exclusive Heath Magna-Shield!

This unique metal shield surrounds the entire picture tube to help keep out stray external fields and improve color purity. In addition, *Automatic Degaussing* demagnetizes and "cleans" the picture everytime you turn the set on from a "cold" start . . . also permits you to move the set about freely without any manual degaussing.



Vertical Swing-Out Chassis!

All parts mount on a single one-piece chassis that's hinged to make it more accessible for easier construction, care and installation.

Your Choice Of Installation!

Another Heathkit exclusive . . . the GR-180 is designed for mounting in a wall or your own custom cabinet. Or you can install it in either of Heath's factory-assembled and finished cabinets . . . the contemporary styled walnut model, shown above, at \$49.95, or a deluxe Early American cabinet at \$75.00.



From Parts To Programs In Just 25 Hours!

. . . and no special skills or knowledge needed. All critical circuits (VHF and UHF tuners, 3-stage IF assembly and high voltage power supply) are prebuilt, aligned and tested at the factory. The GR-180 manual guides you the rest of the way with simple, non-technical instructions and giant pictorials. It's like having a master teacher at your elbow pointing out every step. You can't miss.

Compare These Advanced Performance Features . . . And The Price!

Hi-Fi 180 Sq. Inch Rectangular Tube with anti-glare safety glass, plus "rare earth phosphors", smaller dot size and 24,000 volt picture power for brighter, livelier colors and sharper picture definition.

Automatic Color Control and gated automatic gain control to reduce color fading, and insure steady, jitter-free pictures even under adverse interference such as nearby aircraft traffic.

Deluxe VHF Turret Tuner with "memory" fine tuning so you don't have to readjust everytime you return to a channel.

2-Speed Transistor UHF Tuner for either fast station selection, or fine tuning of individual channels.

Two Hi-Fi Sound Outputs . . . a cathode follower for play through your hi-fi system, plus an 8 ohm output for connection to the GR-180's limited-field 4" x 6" speaker.

Two VHF Antenna Inputs . . . a 300 ohm balanced and a 75 ohm coax to reduce interference in metropolitan or CATV areas.

1-Year Warranty on the picture tube, 90 days on all other parts. In addition, liberal credit terms are available.

*Kit GR-180, everything except cabinet for custom mounting, 102 lbs. . . . \$379.95
Assembled GRA-180-1, walnut cabinet shown above, 30 lbs., 18 1/4" D x 28 1/4" W x 29" H. . . \$49.95
Assembled GRA-180-2, Early American cabinet, 37 lbs., 18 1/4" D x 28 1/4" W x 31 1/4" H. . . Available February. . . . \$75.00

FREE Heathkit Catalog

. . . with full details on this unique set. Mail the coupon on the following page, or write Heath Company, Benton Harbor, Michigan 49022. Better yet, use the coupon to order the best 19" Color TV buy . . . now!



Turn Page For More New Kits From HEATH

Circle 28 on reader's service card

12 Kit-Giving Ideas From HEATH...

NEW! Deluxe Solid-State FM /FM Stereo Table Radio



Kit GR-36
\$69⁹⁵

Tuner and IF section same as used in deluxe Heathkit transistor stereo components. Other features include automatic switching to stereo; fixed AFC; adjustable phase for best stereo; two 5 1/4" PM speakers; clutched volume control for individual channel adjustment; compact 19" W x 6 1/2" D x 9 1/4" H size; preassembled, prealigned "front-end"; walnut cabinet; simple 10-hour assembly. 24 lbs.

NEW! Compact 2-Way 2 Speaker System With Acoustic Suspension Design

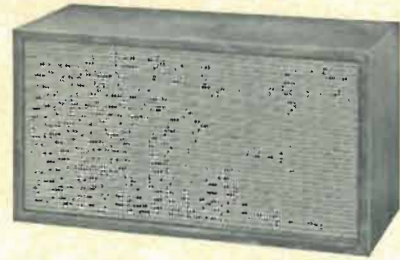

Kit AS-16
\$49⁹⁵

Handles 10 to 25 watts of program material. Features wide 45 to 20,000 Hz response; 8" acoustic suspension woofer with 6.8 oz. magnet; 3 1/2" tweeter with 4.8 oz. magnet; high frequency level control; 8 ohm impedance; 1500 Hz crossover frequency; assembled walnut veneer cabinet has scratch-proof clear vinyl covering for easy cleaning. Measures 10" H x 19" W x 8 1/2" D. Speakers are already mounted; just wire the crossover and connect cables — complete in one or two hours! 17 lbs.

NEW! Amateur Radio Single-Bander Transceivers ... New Features ... Choose 75, 40 or 20 Meters



Kit HW-12A
75-Meter
\$99⁹⁵

Now features upper or lower sideband operation on all models; new deluxe styling; more convenient control locations; 200 watts P.E.P. input; single knob tuning with 2 kHz dial calibration; new ALC input for use with external linear amplifiers; improved audio and AVC response; crystal filter type SSB generation; built-in S-meter, VOX, PTT and ALC; fixed or mobile operation. 15 lbs. Kit HW-22A, 40-meter.. \$104.95. HW-32A, 20-meter.. \$104.95

NEW! Deluxe Amateur Station Console ... 4 Separate Units In One!



Kit SB-630
\$74⁹⁵

Includes 24-hour clock, SWR meter, hybrid phone patch and an all-electronic 10-minute timer with audio/visual signaling in one compact unit. Matched in styling and performance with the famous Heath Deluxe SB-Series amateur radio equipment. Measures a compact 6" H x 10" W x 11 1/4" D. 9 lbs.

NEW Heathkit®/Magnetic® 1020 4-Track Stereo Recorder Kit



Kit AD-16
\$399⁵⁰
(less cabinet)

Save \$170 By Doing The Easy Assembly Yourself. Takes around 25 hours. Features solid-state circuitry; 4-track stereo or mono playback and record at 7 1/2" & 3 3/4" ips; sound-on-sound, sound-with-sound and echo capabilities; 3 separate motors; solenoid operation; die-cast top-plate, flywheel and capstan shaft housing; all push-button controls; automatic shut-off at end of reel; plus a host of other professional features. 45 lbs. Optional walnut base \$19.95, adapter ring for custom or cabinet installation \$4.75

Now Play In Minutes Instead Of Months ... Heathkit®/Thomas COLOR-GLO Organ



Kit GD-325B
\$394⁹⁰

Color-Glo Key Lights Show You the correct notes and chords ... you play melody, harmony and bass notes instantly ... even if you've never played an organ before! When you're finished, just flip a switch and the key lights disappear, leaving a beautiful spinet organ. Includes 10 voices, repeat percussion, 13-note bass pedals, two 37-note keyboards, assembled walnut cabinet & bench and more. Fully transistorized. Builds in around 50 hours and you save up to \$150! 172 lbs.

Circle 28 on reader's service card

Something For Everyone

NEW 12" Transistor Portable TV Kit

Kit GR-104
\$119⁹⁵



First Kit With Integrated Circuit . . . replaces 39 parts! Unusually sensitive performance. Plays anywhere . . . runs on household 117 v. AC, any 12 v. battery, or optional rechargeable battery pack (\$39.95); preassembled, prealigned tuners; high gain IF strip; Gated AFC for steady, jitter-free pictures; assembles in only 10 hours. Cabinet measures 11 1/2" H x 15 3/4" W x 9 3/8" D. 23 lbs.

NEW Transistor Portable Phonograph Kit

Kit GD-16
\$39⁹⁵



Worth At Least 50% More! And it sounds better. Assembles in just 1 to 2 hours . . . simply wire one small circuit board, mount the 4" x 6" speaker and plug in the preassembled changer . . . ideal beginner's kit. Features automatic mono play of all 4 speeds; dual Sapphire styli for LP's or 78's; 45 rpm adapter; olive and beige polyethylene over sturdy, preassembled cabinet. Operates on 117 v. AC. 23 lbs.

NEW Deluxe SB-301 Amateur Receiver Kit NEW Deluxe SB-401 Amateur Transmitter Kit



Kit SB-301
\$260⁰⁰
(less speaker)

New SB-301 receiver for 80 Thru 10 Meters with all crystals furnished, plus 15 to 15.5 MHz coverage for WWV; full RTTY capability; switch-selected ANL; front-panel switching for control of 6 and 2 meter plug-in converters; crystal-controlled front-end for same tuning on all bands; 1 kHz dial calibrations — 100 kHz per revolution. 23 lbs. Matching SB-401 transmitter, now with front-panel selection of independent or transceive operation . . . \$285.00

NEW 2-Watt Transistor Walkie-Talkie

Assembled GRS-65A
\$99⁹⁵



Completely Assembled. Features 2 watts of power for up to 6 mile range . . . up to 10 miles when working a 5-watt CB rig; \$20 rechargeable battery; 9 silicon transistor, 2 diode circuit; superhet receiver; adjustable squelch, ANL; aluminum case. 3 lbs. Optional 117 v. AC battery charger cord plus cigarette lighter cord \$9.95. Crystals extra @ \$1.99 each with order.

66-Watt Solid-State AM/FM/FM Stereo Receiver

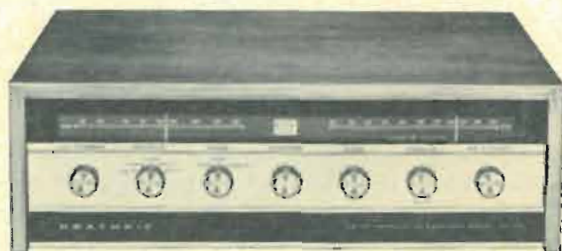

Just Add 2 Speakers For A Complete Stereo System. Boasts AM, FM and FM stereo tuning; 46 transistor, 17 diode circuit for cool, instant operation and natural transistor sound; 66 watts IHF music power (40 watts RMS) at ± 1 db from 15 to 30,000 Hz; automatic switching to stereo; preassembled & aligned "front-end" & AM-FM IF strip; walnut cabinet. 35 lbs.

Kit AR-13A
\$184⁰⁰

30-Watt Solid-State FM/FM Stereo Receiver

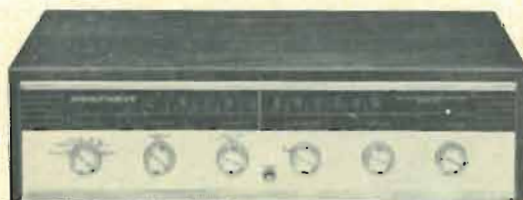

World's Best Buy In Stereo Receivers. Features 31 transistors, 10 diodes for cool, natural transistor sound; 20 watts RMS, 30 watts IHF music power @ ± 1 db, 15 to 50,000 Hz; wideband FM/FM stereo tuner; plus two pre-amplifiers; front panel stereo headphone jack; compact 3 7/8" H x 15 1/4" W x 12" D size. Custom mount it in a wall, or either Heath cabinets (walnut \$9.95, beige metal \$3.95). 16 lbs.

Kit AR-14
\$99⁹⁵



FREE! World's Largest Electronic Kit Catalog!

Features over 250 kits for stereo, color TV, amateur radio, shortwave, test, CB, marine, educational, home and hobby. Save up to 50% by doing the easy assembly yourself. Mark orders with kit to Heath Company, Benton Harbor, Michigan 49022.

HEATH COMPANY, Dept. 20-12
Benton Harbor, Michigan 49022
In Canada, Daystrom Ltd.

Enclosed is \$ _____, plus shipping.

Please send model (s) _____

Please send FREE 1967 Heathkit Catalog.

Name _____

Address _____

City _____

State _____

Zip _____

Prices & specifications subject to change without notice.

CL-263

Complete TUNER REPAIR

\$9.50

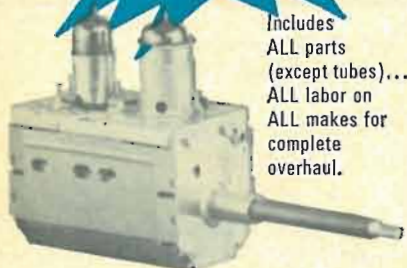

Includes
ALL parts
(except tubes)...
ALL labor on
ALL makes for
complete
overhaul.

FAST, 24-HOUR SERVICE with FULL YEAR WARRANTY

Sarkes Tarzian, Inc., largest manufacturer of TV and FM tuners, offers unexcelled tuner overhaul and factory-supervised repair service.

Tarzian-made tuners received one day will be repaired and shipped out the next. More time may be required on other makes. Every channel checked and realigned per original specs. And, you get a full, 12-month guarantee against defective workmanship and parts failure due to normal usage. Cost, including labor and parts (except tubes) is only \$9.50 and \$15 for UV combinations. Replacements at low cost are available on tuners beyond practical repair.

Always send TV make, chassis and Model number with faulty tuner. Check with your local distributor for Sarkes Tarzian replacement tuners, parts or repair service. Or, use the address nearest you for fast, factory-supervised repair service.

TUNER SERVICE  CORPORATION

(Factory-supervised tuner service
authorized by Sarkes Tarzian)

MIDWEST—817 N. Pennsylvania St.
Indianapolis, Ind. Box 1642
Tel: 317-632-3493

EAST—547-49 Tonnele Ave.,
Jersey City, New Jersey
Tel: 201-792-3730

SOUTH-EAST—938 Gordon St., S.W.,
Atlanta, Georgia
Tel: 404-758-2232

WEST—SARKES TARZIAN, Inc.
Tuner Service Division
10654 Magnolia Blvd., N. Hollywood, Calif.
Tel: 213-769-2720

EQUIPMENT REPORT

EICO 888 "Auto Analyzer"

Circle 29 on reader's service card

MY PRIMARY INTEREST IS ELECTRONICS, but I'm a car buff, too. I've got a very small, very red car, and I do my own mechanical work. [He means he's a shade-tree mechanic.—*Editor*] I was very happy when the Editor sent me the new Eico 888 Auto Analyzer. Li'l red car was showing signs of needing just such an analysis: hard starting, bucking and so forth.



I ran my li'l red wagon out under a big tree [See? What'd I tell you?—*Editor*] and cleaned up the engine with a detergent. Now, it was very clean—also very dead. The Eico 888's SPARK test showed nothing, so I cleaned and dried out the distributor. Still no spark. I could see the points were closed, but the ohmmeter test said they were not making contact. After I cleaned them up, the engine ran again.

The spark test at each plug now showed good. I checked the dwell angle (the percentage of time the distributor points stay closed), and it was far too low—45° instead of the normal 60°. New points and another dwell check corrected this, also improved the starting and running of the engine. To check the distributor condenser, I substituted the one in the 888 for it. (They may be capacitors in TV, but in cars they're still condensers.)

This instrument will make rapid tests on the entire electrical system of any car. Little red car obviously knew this and obliged by blowing up its generator a couple of days later. When the new one was installed, I ran a full set of tests on the generator and voltage regulator.

The 0-16-volt dc scale on the meter reads battery voltage, and cut-in and cut-out points for the voltage regulator. With the engine off, a fully-charged 12-volt battery should read 12.6 (easily seen on the 6-inch meter used in the 888). This voltage should stay within 0.5 volt under normal load such as the headlights. Too much change indicates a partly discharged battery, or even a bad cell. The 0-3.2-volt dc scale is ideal for checking

individual cells (2.1 volt each).

This low scale is also very useful to check for excessive voltage drop in wiring, dirty connections or noisy switches and the like.

For example, if the starter doesn't turn as fast as it ought to, connect the 16-volt scale directly across the switch terminals. Pull the center wire out of the ignition coil and try the starter. There should never be more than 0.5-volt drop across a good starter switch.

Another use is to check for proper grounding. Connect one meter clip to the ground connection of the suspected accessory and the other to the ground post of the battery. Turn on whatever it is. If you see more than a 0.2-volt drop on the meter, clean and tighten the ground connections.

A pulse-width measuring circuit checks dwell angle on distributor points. The longer the points stay closed, the longer the pulses are—so the meter reading goes higher.

The tachometer uses a transistorized Schmitt-trigger pulse-counting circuit. My little car has a very accurate mechanical tachometer, and this agreed exactly with the tach reading of the 888.

The SPARK test shows the strength of ignition at all plugs, on a LO-HI range. As I discovered, this is useful for spotting loose wiring in the distributor cap or for revealing fouled plugs. (It's also handy for settling arguments about whether sparkplug suppressors cut down the spark at the plugs. They don't but sometimes it's hard to prove.)

For checking the charging rates of generators and alternators, current can be measured by using a special shunt. This lets the meter read current up to 90 amps dc.

To check charge rate, hook the current shunt between the B (battery) terminal of the voltage regulator and its wire. Connect the meter to terminals on the shunt, which are marked for polarity. With the engine idling, an alternator should show 15-20 amps. A generator will show less at idle, but should go up to 20-25 amps at 1,000-1,500 rpm. (The 888's tachometer will tell you the engine speed.) When the battery won't "stay up" and charge current is only 4-6 amps, the fanbelt may be slipping. This has happened (guess who to).

Rectifier diodes on alternators can be tested for shorts or opens with OHMS-DIODE-LEAK test. The alternator diode is disconnected and the meter leads are hooked across it. The meter will read either full scale or very low. Push the FWD-REV (forward-reverse) switch on the panel, and meter polarity will be reversed. If the reading was full-scale, it should go very low, and vice versa. If the reading does not change, the diode

is either shorted or open.

For voltage regulator and generator testing, you can use a voltage test. Voltage should run up to about 14 with the engine at fast idle. If the voltage stays at 12 or less, something's wrong. Disconnect the regulator and check the generator to make sure that it is putting out enough.

The 888 can even be used to check carburetor adjustments! Hook up the tachometer, run the engine at fast idle, and take off the air cleaner. If rpm goes up, the air cleaner's clogged. Idling adjustments on cars with automatic transmissions can be set for the exact speed recommended by the manufacturer.

The tachometer needs only a connection to the distributor lead of the coil. With an extension wire, the 888 can be set up inside the car and used for road tests. This is handy for checking up-shift and down-shift points on automatic transmissions. The ground lead can be hooked to any metal part on the inside of the car.

The 60-Hz power-line frequency is used to calibrate. An ac cord with a voltage-dropping device is plugged into the TEST jacks. The meter range is set for 1,200 rpm, 6-cylinder. The RPM-CAL switch is pushed, and the meter can be set to full scale with the RPM adjustment. Small variable resistors, accessible through holes in the back of the case, individually calibrate each range.

The test leads are a full 6 feet long. With alligator clips yet! The instrument can be set on a fender, bench or even the floor, and still the test leads will reach! (When making tests with the engine running, keep them out of the fan!)

Power comes from a 6-volt internal battery, with four D-cells. Total current drain is only 5 mA, so battery life should be good. In fact, I cleverly left the 888 on for about 3 days, and it didn't seem to bother the batteries a bit. It will work with batteries as low as 4 volts. As long as the ohmmeter will still reach full scale, batteries are okay.

The instruction book covers tests on all kinds of cars. In the back are tables of dwell angles, idle rpm's and so on, for all American cars and most foreign ones—including sports cars. (The 888 will work just as well on marine engines!) On cars with positive ground, you have to reverse the test leads.

Having finally gone over the whole system on my little car, I had it running like a dollar watch. As I stood there beaming and listening to that engine purr, my daughter rushed up with an armload of baggage. She dropped it all in the boot, hopped in and drove off to college. So, there went little red car! Proves the old definition of a pedestrian: a man with one car and one kid. You can't win!—*Jack Darr* END

Price: \$44.95 kit, \$54.95 wired

Did you ever...

... lift a wire-lead component from a printed wiring board for testing?



... test or replace a capacitor or resistor on a crowded tube socket?

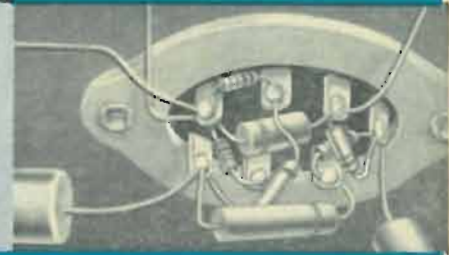

CUT YOUR TIME IN HALF with **KWIKETTE** Soldering-Aids

...the revolutionary connectors that practically let you do "in-circuit" component testing!



(six times actual size)

WIRE FLUX SOLDER

The KWIKETTE SOLDERING AID is not just another wire spring connector! It has a Copperweld wire inner core, an intermediate layer of flux, and an outer jacket of solder... all you need is heat!

KWIKETTES are now being packed with Sprague Atom® Capacitors at no extra cost to you! Whenever you need tubular electrolytics, insist on pre-packaged Sprague Atoms from your parts distributor and you'll automatically get your KWIKETTE component connectors... the biggest boon to the service technician since the soldering gun!

*trademark

FREE TRIAL PACKAGE!

10 free KWIKETTE Soldering Aids are yours for the asking! Simply send your postcard request to KWIKETTE Center, Sprague Products Co., 81 Marshall Street, North Adams, Mass. 01247. Don't forget to include the name of your Sprague Distributor.

SNIP LEAD...



TEST...



SLIP ON KWIKETTE...

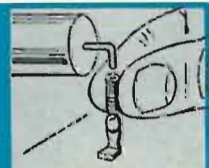

APPLY HEAT!

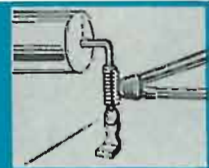

SPRAGUE®

THE MARK OF RELIABILITY

WORLD'S LARGEST MANUFACTURER OF CAPACITORS

65-6109

Circle 30 on reader's service card

you get

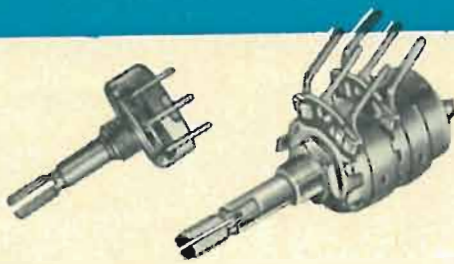

**full color TV
component
coverage
with Centralab's
quality products**

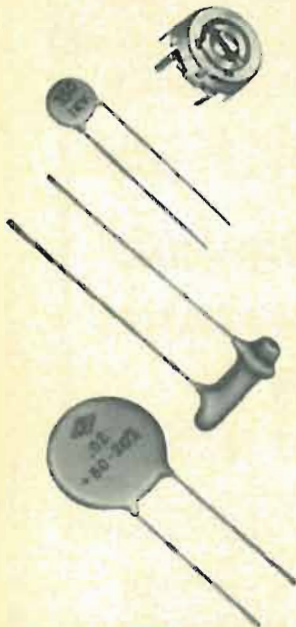

COLOR TV CONTROLS

Centralab has the exact replacement you need. Single controls, buzz controls, dual concentrics, and twins. With the Fastatch II® system, your Centralab distributors can supply any one of over 9 BILLION different exact replacement control combinations. That's coverage!

COLOR TV CAPACITORS

Centralab has them all: polystyrenes, low-voltage ceramics, trimmer ceramics and the new miniaturized electrolytics. Rely on us for the exact replacement—discs and tubulars, any standard voltage, any standard capacitance. That's coverage!

COLOR TV PACKAGED CIRCUITS

Centralab invented the packaged circuit . . . and has produced over 300,000,000 to date. We've got more exact replacements for color tv, with new ones being added regularly. That's coverage!

FOR COMPLETE COLOR TV COVERAGE . . .
WITH THE FINEST QUALITY REPLACEMENTS . . .
RELY ON YOUR CENTRALAB DISTRIBUTOR
Write for your free catalog to Distributor Products, Centralab,
P.O. Box 591, Milwaukee, Wisconsin 53201.

Centralab

DIVISION OF GLOBE-UNION INC.

Circle 31 on reader's service card

**WORLD "MEDICO" RECORD
SET BY HAM OPERATOR?**

"Patching up" a medical conference between a surgeon in a London hotel room and a Navy surgeon in a hospital ship off Viet Nam, amateur radio operator W6RT of Solana Beach, Calif., believes he has set up "some kind of a world's record" in MEDICO communication. (MEDICO is the radio term for messages asking for medical advice or consultation.)

W6RT—Brigadier General James G. Smith, USMC, retired—heads a group of West Coast amateurs who receive messages from wounded Marines aboard the hospital ship *Repose* and friends or relatives in the States. The messages are then "patched" into the land phone line for transmission as regular long-distance calls to any part of the United States. Shipside arrangements are made by W6RT's friend Capt. E. H. Maher, who commands the *Repose*.

The priority MEDICO call asked W6RT to contact Dr. Arthur Bell in Texas, but Bell was attending a medical conference in Europe. Tracking the doctor through France and Scandinavia, W6RT located him in London and patched the trans-Atlantic, transcontinental call into the ham circuit to the *Repose*. Dr. Bell and Dr. Neugebauer, Navy surgeon aboard ship, then discussed the operation and the successful use of a do-it-yourself artificial heart pump operating on flashlight batteries. "The two doctors chatted about the operation" said Smith, as if "neither one seemed to realize they were half a world apart." As a matter of fact, their conversation went three-fifths of the way around the globe, making the world record claim seem reasonable indeed. END

**At Last—
Direct View 3-D Images!**

Imagine seeing what looks like a solid object, but when you reach out to touch it there's nothing there! Hallucination? Illusion? No—just modern scientific fact. Laser Holography is the phenomenal development responsible. Read our new science editor's revealing article in January RADIO-ELECTRONICS.

CB Troubleshooter's Casebook

Compiled by
Andrew J. Mueller

Case 1: No transmit or receive.
Common to: Hammarlund CB-23.

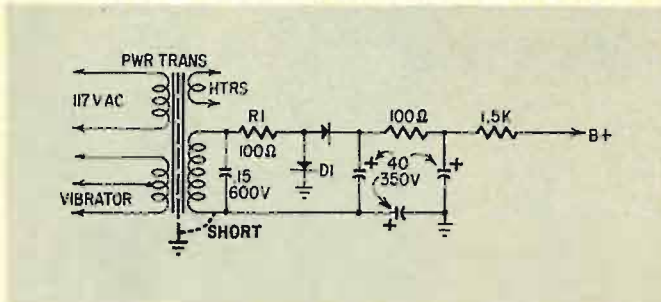

Remedy: Replace power transformer, R1 and D1.
Reasoning: Power transformer developed a short from the high-voltage secondary to ground. The short caused high current flow through the transformer, D1 and R1, which burned open. Although D1 may seem okay, it should be replaced as a precaution against a callback.

Case 2: Receiver dead, transmitter normal; S-meter dead in receive mode, works in transmit mode.
Common to: Olson Spotter 2.

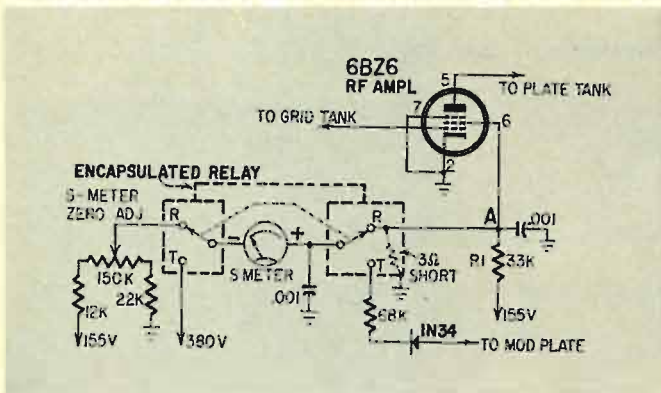

Remedy: Replace TR (transmit-receive) relay and R1.
Reasoning: The encapsulated TR relay developed an internal short of 3 ohms to ground, pulling too much current through R1, and lowering screen voltage on the 6BZ6 to the point where no signal was getting through the stage. In addition to the relay, replace R1, for it may have changed value due to overheating.

NEW! LAFAYETTE HB-525 Solid State 2-Way Radio



99-3076WX*

• Size: 2³/₈" by 6¹/₄"

149⁹⁵

All **23** Channels
Crystal Controlled

Plus 2 Reserve Channels For H.E.L.P. Program
All Crystals Supplied!

- 19 Transistors, 7 Diodes, Thermistor
- Dual Conversion Receiver for Extra Selectivity and Sensitivity
- Full 5-Watt Input
- Range Boost™ Circuitry for Added Power
- 3-Position Delta Tune—Provides Accurate Fine Tuning
- Mechanical 455KC Filter for Superior Selectivity
- Push-to-Talk Dynamic Microphone
- Variable Squelch plus Series Gate Automatic Noise Limiting
- Public Address System (with external speaker)
- 12-Volt DC Operation (pos. or neg. ground) 6-Volt DC (with optional DC Power Supply)
- Pi-Network for Optimum RF Output

*Imported



FREE

**1967
CATALOG 670**

512 Pages

Featuring Everything in Electronics for
• HOME • INDUSTRY • LABORATORY
from the "World's Hi-Fi & Electronics Center"

LAFAYETTE Radio ELECTRONICS
Dept. J L-6 P.O. Box 10
Syosset, L. I., N. Y. 11791

Send me the FREE 1967 Lafayette Catalog 670

J L-6

Name

Address

City State Zip

Circle 32 on reader's service card



**More heat
where it counts
for greater
soldering efficiency** →

It's impossible to get the performance you expect from a soldering gun unless it converts its rated watts into heat at the tip.

Weller guns deliver the most heat per rated watt. They melt solder faster, and assure more reliable soldered connections than any other soldering guns.

For the most efficient heat, fastest heat, and exclusive trigger-controlled dual heat—insist on Weller.

Weller Dual Heat Guns and Kits come in wattage ranges from 100 to 325, priced from \$6.95 to \$12.95 list.

Weller®

WELLER ELECTRIC CORP., EASTON, PA.

In Canada: Kingston, Ontario. In England: Horsham, Sussex.

WORLD LEADER IN SOLDERING TECHNOLOGY

Circle 33 on reader's service card

Case 3: Audio feedback during receive at various settings of squelch control; audio squeal during transmit.

Common to: Pearce-Simpson Companion I.

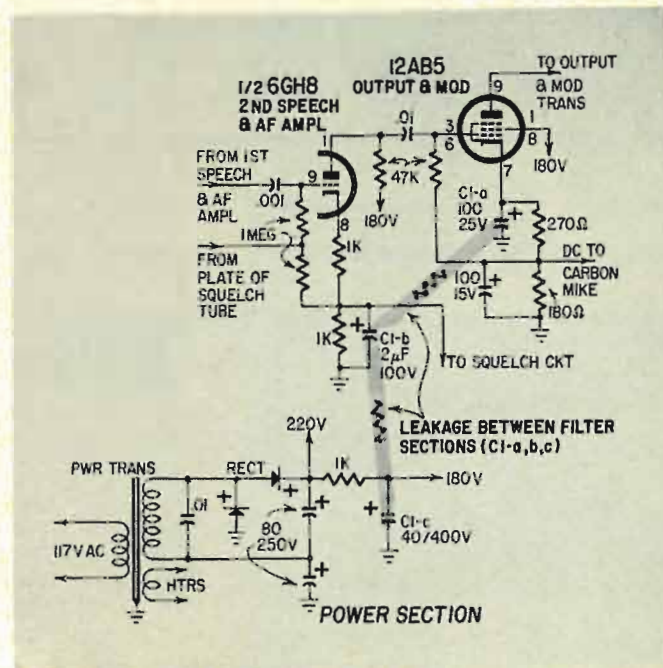

Remedy: Replace filter capacitor C1-a, -b, -c.

Reasoning: After many hours of operation under high cabinet temperature, electrolytic capacitors dry out and develop leakage between sections. Such leakage between the three sections of C1 causes undesirable coupling between the audio stages and other transceiver stages. **Note:** Shunting a new filter across the existing one in this circuit will not reveal the trouble.

Case 4: Intermittent receive when cabinet cover is in place; transmit okay.

Common to: Cadre 510.

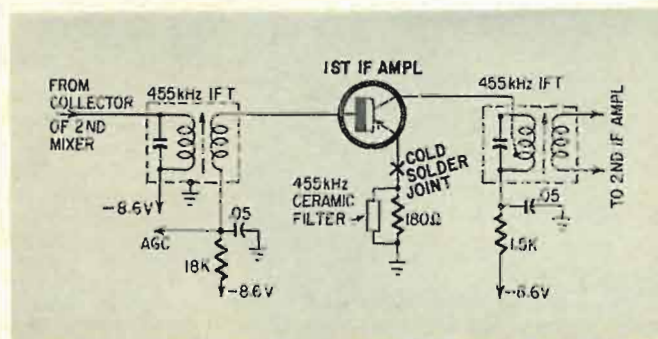

Remedy: Resolder cold solder joint at emitter of first i.f. transistor.

Reasoning: Receiver worked normally for hours. When it cut out, removal of the cabinet cover "cured" the trouble. Prodding the circuit-board connections with an insulated plastic probe revealed the cold solder joint.

Case 5: Receiver very weak (lack of sensitivity); transmitter normal.

Common to: E.C.I. Courier TR-6.

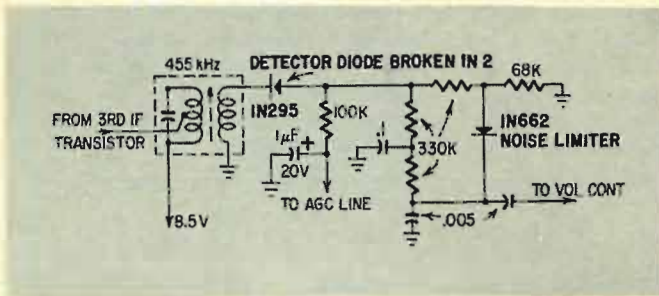

Remedy: Replace broken detector diode.

Reasoning: Output from an rf signal generator was coupled through antenna terminals and traced to the second detector stage, where it practically disappeared. Use of plastic probe revealed broken diode, whose leads had been strained during installation. Be sure to use heat sink when replacing diode, and allow slack in leads to avoid subsequent strain and breakage.

Case 6: Transmitter rf output low; receiver okay.

Common to: DEMCO Traveler.

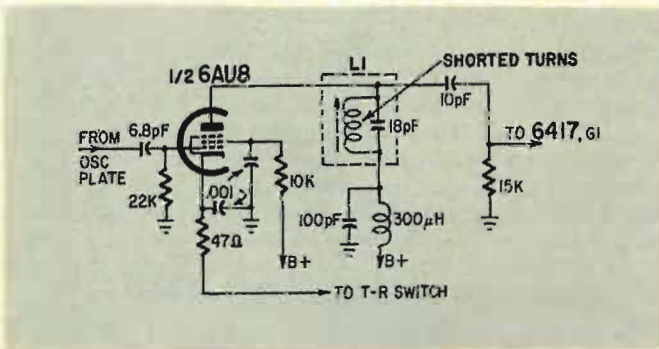

Remedy: Replace buffer coil L1.

Reasoning: Shorted turns in L1 reduce circuit Q and also rf output (due to reduced grid drive to 6417 final). A fault like this can be quickly located by tuning up the transmitter according to manufacturer's instructions. When you find a coil that hasn't a resonant point, it's probably defective. After replacement of L1, run through transmitter alignment once more. Be sure the transmitter is connected to the station antenna for the final amplifier tune-up. (Remember the person who makes these adjustments must hold an FCC Second-Class License, or better.)

DO YOU THINK . . .

CB Troubleshooter's Casebook should be continued? We have more of these case histories for you, but only if they are useful. We want to be sure the Casebook does the job we designed it for. Let us know if you want it carried on. At the same time, if you have had an unusual CB-servicing experience you'd like to share with other readers, send it along. Casebook's future is up to you.—Editor

END

**BIGGER... BETTER
THAN EVER!**

FREE!



**SEND TODAY FOR YOUR NEW
40th ANNIVERSARY
1967 CATALOG**



YOUR BUYING GUIDE FOR

- Stereo & Hi-Fi Systems & Components.
- Tape Recorders.
- Electronic Parts, Tubes, Tools.
- Phonos & Records.
- Cameras and Film.
- Public Address.
- Citizens Band.
- Ham Gear.
- Transistor & FM-AM Radios.

**252 GIANT VALUE
PACKED PAGES!**

BURSTEIN-APPLEBEE CO.

Dept. RE, 1012 McGee, Kansas City, Mo. 64106

Rush me the FREE 1967 B-A Catalog.

Name.....

Address.....

City.....

State..... Zip Code.....

Circle 34 on reader's service card

4th Annual Color TV Issue . . . January RADIO-ELECTRONICS

. . . Wonder Why Purity and Convergence Interact?

Incorrect color on one part of the color screen may be caused by impurity or by misconvergence. The two are inter-related, but separate. The reasons and remedies are explained in the January issue of RADIO-ELECTRONICS.

. . . The Color TV Signal

is usually discussed from the receiver point of view. The signal doesn't spring full-blown into existence though. Knowing how it's produced at the camera will help you to understand it at the receiver. Read "Development of a Color TV Signal" in RADIO-ELECTRONICS for January.

. . . Plus features on radio, audio, general electronics.

RADIO-ELECTRONICS 4th Annual Color TV Issue on sale December 22 at your parts distributor and newsstand.

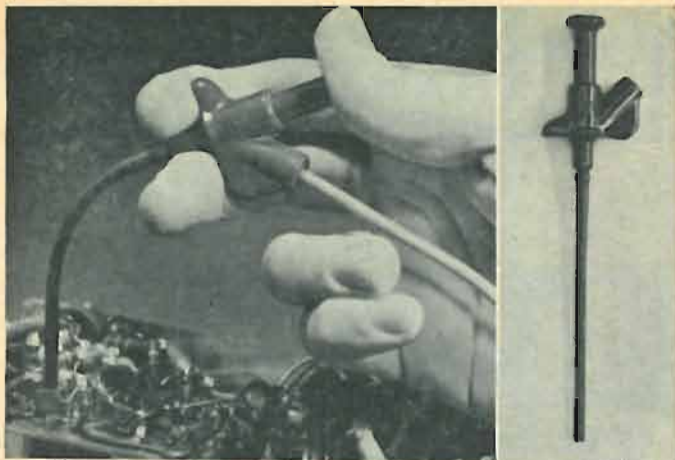

Clever Kleps 30

Push the plunger. A spring-steel forked tongue spreads out. Like this Hang it onto a wire or terminal, let go the plunger, and Kleps 30 holds tight. Bend it, pull it, let it carry dc, sine waves, pulses to 5,000 volts peak. Not a chance of a short. The other end takes a banana plug or a bare wire test lead. Slip on a bit of shield braid to make a shielded probe. What more could you want in a test probe?



Available through your local distributor, or write to:

RYE INDUSTRIES INC.

126 Spencer Place, Mamaroneck, N.Y. 10543

Circle 35 on reader's service card

\$147

TECHNOTES

FUSE-EATING POWER SUPPLY

This Gonset G-76 dc power supply was blowing its 30-amp main fuse. Close inspection revealed that all four of the 2N1554 transistors had fused. The supply was a recent one, using a small square iron-core power transformer. The four transistors were replaced with RCA SK3009's. However, after 3 minutes of operation, they also fused.

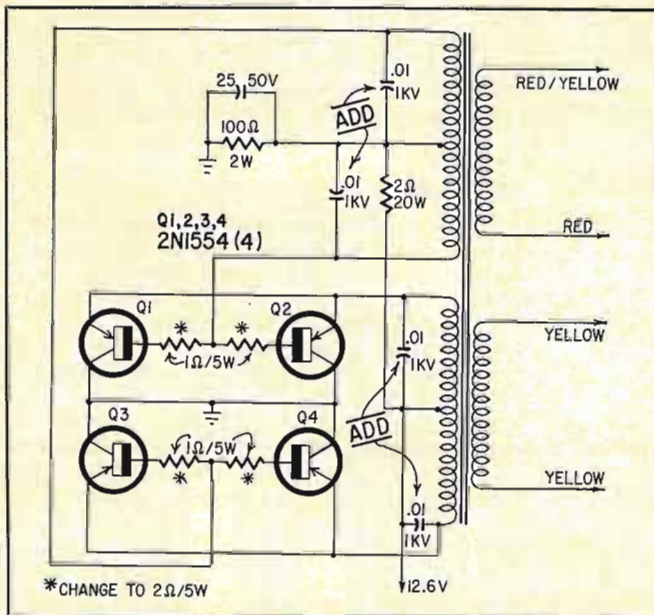

Direct-replacement Motorola 2N1554's were ordered. After they were installed, a scope was connected between base and emitter of each transistor. Lo and behold—there was a sharp spike! The base resistors were replaced with 2-ohm 5-watt units, and four .01- μ F 1,000-volt capacitors were connected between center-taps and ends of the two primary windings of the power transformer. This cured the trouble permanently.—George P. Oberto

BELL T-220 SERIES TAPE TRANSPORTS

In some of these transports, when the RUN button is depressed, the tape coming from the supply reel will bounce

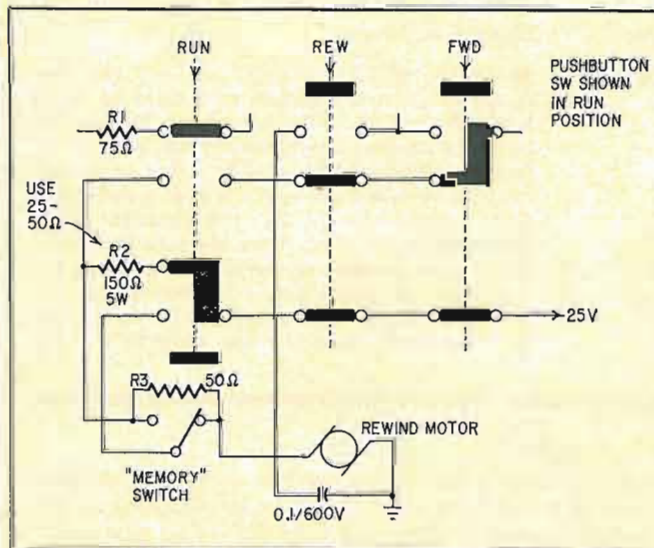

a few times before the reel starts to move evenly. Wow will appear at the beginnings of recordings.

To solve the problem, replace R2 with 25-50-ohm re-

Sales-wise, profit-wise and otherwise, you'll do very well with Browning CB radio equipment.

Many territories available for Franchised Browning Sales and Service Centers. Sell the nationally advertised Eagle CB base station and Raven mobile unit in your exclusive territory. Complete sales aids and technical assistance furnished. Get all the facts now and cash in on the top selling Browning CB line.

Browning Laboratories, Inc.
Department E3
1269 Union Avenue, Laconia, New Hampshire

Please send me information on Franchised Browning Sales and Service Centers.

NAME _____

ADDRESS _____

STATE _____

ZIP CODE _____

CITY _____

MAIL THIS COUPON TODAY!



browning

LABORATORIES, INC.

1269 Union Avenue, Laconia, New Hampshire 03246

Circle 36 on reader's service card

sistor, 5 watts. In a few severe cases R2 will have to be shorted out. The tape speed should not have changed after R2 had been replaced. Slow speed indicates a dirty pressure roller and pulleys, or insufficient pressure between the pressure roller and capstan.—*Sandor Mentler* END

NEW STORAGE BATTERY COULD BRING BACK ELECTRIC AUTOS

A radically new type of storage battery demonstrated to a Detroit press conference could put the Ford Co., in the electric car business within the next 10 years, according to a company spokesman.

The new storage cells differ markedly from all previous storage batteries: It operates at 800° Fahrenheit. It is completely sealed, with no need to vent charging gases. It produces 15 times as much power as a lead-acid battery of the same weight.

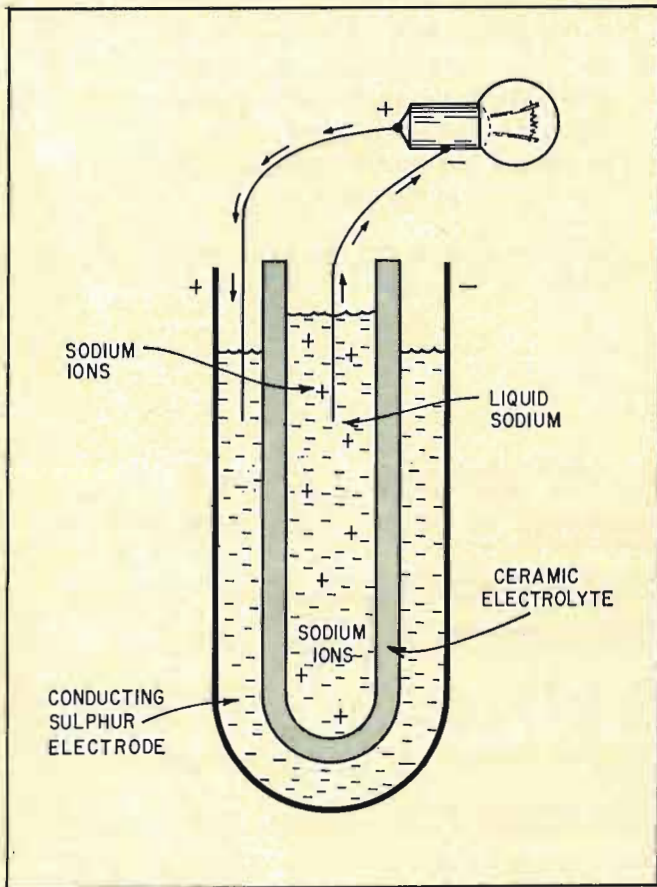

The active elements of the new cell are sodium and sulphur. These are separated by a ceramic partition (reminiscent of the porous cup used in old liquid primary cells, but now called "the electrolyte" apparently in imitation of fuel-cell terminology). Electrons are given off at the sodium terminal. The positive sodium ions then move through the ceramic and unite with the sulphur to form sodium sulphide. In charging, the process is reversed; the sodium ions go back through the ceramic electrolyte and unite with electrons injected by the charger to form sodium again. The process produces no gases or other byproducts.

General Electric and General Motors are both said to be working on a battery for motor cars—whether storage or fuel-cell type is not known. The electric car is just below the practical level today—there are a few electric delivery trucks in every large city—and problems of air pollution prevention are bound to increase the costs of gas-driven devices. The prediction "electric cars in 10 years" may therefore turn out to have been overcautious. END

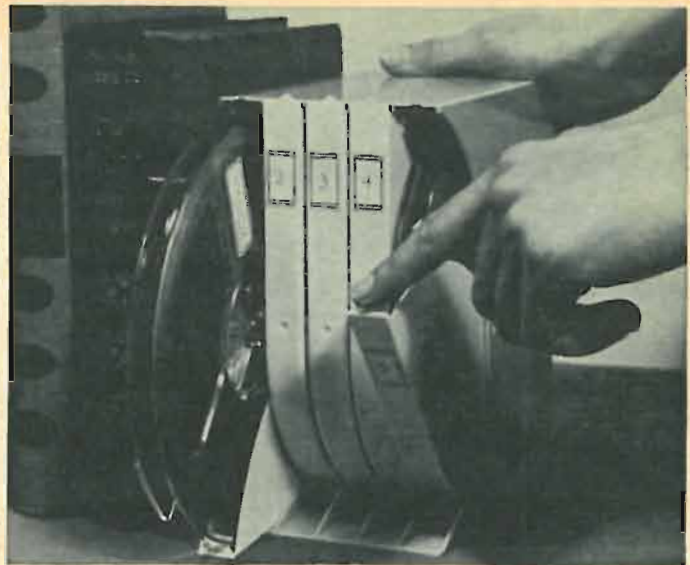

A clever tape file

Stores 5 reels in one sturdy plastic case with swing-out compartments. Protects these valuable tapes, keeps them handy, indexed and orderly. Stacks horizontally or vertically, comes in three sizes (for 3-, 5-, 7- inch reels). Handsome two-tone beige. (A neat 8-mm film file too!)

3": \$2.99
5": \$4.45
7": \$4.95
 (all prices less reels)



Available through your local distributor, or write to:
RYE INDUSTRIES INC.
 126 Spencer Place, Mamaroneck, N.Y. 10543
 Circle 37 on reader's service card

Designed and manufactured in U.S.A.

NEVER A BURNOUT
 IN 6 EMC DIODE-PROTECTED VOMS

NOBODY ELSE BUT EMC DESIGNS IN SO MUCH VALUE!
 Professional quality and versatility • Lifetime protection against electrical abuse • No meter burn-out, needle damage, or fuse replacement

VOLOMETER

Model 109A Factory Wired & Tested **\$28.95**
 Model 109AK Easy-to-Assemble Kit **\$21.15**
 20,000 Ω/v DC sens. 10,000 Ω/v AC sens. 4 1/2", 40µa meter. High impact bakelite case. 5 DC voltage ranges: 0-6-60-300-600-3000v. 5 AC voltage ranges: 0-12-120-600-1200-3000v. 3 DC current ranges: 0-6-60-600ma. 3 AC current ranges: 0-30-300ma; 0-3A. 3 resistance ranges: 0-20K, -200K, -20 megs. 5 db ranges: -4 to +67db. With carrying strap. 5 1/4" W x 6 3/4" H x 2 7/8" D.

VOLOMETER

Model 103A Factory Wired & Tested **\$20.75**
 Model 103AK Easy-to-Assemble Kit **\$16.80**
 4 1/2", 2% accurate, 800µa D'Arsonval type meter. One zero adjustment for both resistance ranges. High impact bakelite case. 5 AC voltage ranges: 0-12-120-600-1200-3000v. 5 DC voltage ranges: 0-6-60-300-600-3000v. 5 db ranges: -4 to +64db. 5 AC current ranges: 0-30-150-600ma. 4 DC current ranges: 0-6-30-120ma; 0-1.2A. 2 resistance ranges: 0-1K, 0-1 meg. 5 1/4" W x 6 3/4" H x 2 7/8" D.

POCKET SIZE VOLOMETER

Model 102A
 Factory Wired & Tested **\$16.95**
 Model 102AK Easy-to-Assemble Kit **\$14.40**
 3 1/2", 2% accurate 800µa D'Arsonval type meter. One zero adj. for both res. ranges. High impact bakelite case. 5 AC voltage ranges: 0-12-120-600-1200-3000v. 5 DC voltage ranges: 0-6-60-300-600-3000v. 3 AC current ranges: 0-30-150-600ma. 4 DC current ranges: 0-6-30-130ma; 0-1.2A. Resistance: 0-1K, 0-1 meg. 3 3/4" W x 6 1/4" H x 2" D.



EMC, 625 Broadway, New York 12, N.Y.
 Send me FREE catalog of the complete value-packed EMC line, and name of local distributor.
 RE-12
 NAME _____
 ADDRESS _____
 CITY _____ ZONE _____ STATE _____



ELECTRONIC MEASUREMENTS CORP.
 625 Broadway, New York 12, New York
 Export: Pan-Mar Corp., 1270 B'way, N.Y. 1

The following free advertising material is available through

RADIO-ELECTRONICS READER'S SERVICE

ALLIED RADIO CORP. (Pg. 81) Full details on Knight-Kit Taut-Band VOM.	Circle 106
BLONDER-TONGUE LABORATORIES, INC. (Pg. 16) Catalog #74 of all-channel color-approved couplers.	Circle 15
BRACH MANUFACTURING CORP. (Pg. 86) Complete catalog of antennas.	Circle 117
BROOKS RADIO & TV CORP. (Pg. 96-97) Information sheets and price list of tubes and parts.	Circle 120
BROWNING LABORATORIES, INC. (Pg. 76) Details on operating a franchised Browning Sales & Service Center	Circle 36
BURSTEIN-APPLEBEE CO. (Pg. 75) 1967 catalog.	Circle 34
CASTLE TV TUNER SERVICE, INC. (Page 6) Information on complete tuner overhaul by mail.	Circle 10
CENTRALAB (Pg. 72) Catalog of Centralab color TV quality products.	Circle 31
CLEVELAND INSTITUTE OF ELECTRONICS (Pg. 1) Booklet describing Electronics Slide Rule and Electronics Data Guide.	Circle 8
CORNELL ELECTRONICS CO. (Pg. 102) Catalog and price list of tubes and parts.	Circle 130
DATAK CORP. (Pg. 82) Sample of "Instant Lettering."	Circle 108
DELTA PRODUCTS, INC. (Pg. 87) Literature on Mark Ten Capacitive Discharge Ignition System and Delta Dwell and Tach meters.	Circle 119
DE VRY TECHNICAL INSTITUTE (Pg. 7) Free booklets, "Pocket Guide to Real Earnings," and Electronics in Space Travel."	Circle 11
EICO ELECTRONIC INSTRUMENT CO. (Third Cover) 1967 Catalog.	Circle 149
ELECTRONIC CHEMICAL CORP. (Pg. 84) Information on No Noise aerosol service chemicals.	Circle 111
ELECTRO-VOICE, INC. (Pg. 17) Complete catalogs of phono cartridges and needles.	Circle 16
FINNEY CO. (Pg. 65) Color brochure #20-349 on Finco-Axial Color kit.	Circle 27
HEALD'S ENGINEERING COLLEGE (Pg. 95) Catalog and registration application.	Circle 123
HEATH CO. (Pg. 66-69) Information on new kits and complete 1967 catalog.	Circle 28
INTERNATIONAL CRYSTAL MFG. CO., INC. (Pg. 104) Information on the MO-23 transceiver.	Circle 148
INTERNATIONAL RADIO EXCHANGE (Pg. 82) Complete list of equipment in stock.	Circle 109
JERROLD ELECTRONICS CORP. (Dist. Sales Division) (Pg. 83) Literature on Paralogue-Plus color antenna.	Circle 110
JFD ELECTRONICS CO. (Pg. 14-15) Information on LPV Log Periodic, LPV CL Color Laser and LPV TV Log Periodic antennas.	Circle 14
LAFAYETTE RADIO ELECTRONICS (Pg. 73) 1967 catalog.	Circle 32
MALLORY DISTRIBUTOR PRODUCTS CO. (Pg. 23) Silicon Rectifier Cross Reference booklet.	Circle 19
MULTICORE SALES CORP. (Pg. 84) Information on Ersin Multicore 5-core solder.	Circle 112
MUSIC ASSOCIATED (Pg. 86) Information on Sub Carrier Detector for "music only" programs on FM broadcast band.	Circle 116
OLSON ELECTRONICS, INC. (Pg. 82) Catalog.	Circle 107
OXFORD TRANSDUCER CO. (Pg. 22) Technical bulletins on Oxford standard replacement speakers.	Circle 18
POLY PAKS (Pg. 103) Catalog of semiconductors, Poly Paks and parts.	Circle 131

Here's how you can get manufacturers' literature fast:

1. Tear out the post card on the facing page. Clearly print or type your name and address.
2. Circle the number on the card that corresponds to the number appearing at the bottom of the New Products, New Literature or Equipment Report listing in which you are interested. For literature on products advertised in this issue circle the number on the card that corresponds to the number appearing at the bottom of the advertisement in which you are interested, or use the convenient checking list in the column at the left.
3. Mail the card to us (no postage required in U. S. A.)

RYE INDUSTRIES INC. (Pg. 76) Information "Clever Kleps 30" test probe.	Circle 35
RYE INDUSTRIES INC. (Pg. 77) Information on tape file.	Circle 37
SAMS, HOWARD W., CO., INC. (Pg. 24) Information on Photofact of-the-month club.	Circle 21
SCHOBER ORGAN CORP. (Pg. 5) Free booklet and 7" sampler record.	Circle 9
SENCORE (Pg. 84) Information on Sencore, models CG10 and CG138 standard color bar generators.	Circle 113
SOLID STATE SALES (Pg. 101) Catalog.	Circle 128
SPRAGUE PRODUCTS CO. (Pg. 71) Sample package of 10 Kwikette soldering aids.	Circle 30
SURPLUS CENTER (Pg. 98) Three complete catalogs.	Circle 124
TAB (Pg. 102) Catalog.	Circle 129
TEXAS CRYSTALS (Pg. 87) Catalog with circuits.	Circle 118
TRIPLETT ELECTRICAL INSTRUMENT CO. Information on complete line of VOM's. (Second Cover)	Circle 7
UNITED RADIO CO. (Pg. 100) Tube and parts catalog.	Circle 127
UNIVERSITY SOUND (Pg. 26) Complete 1966-67 P.A. Catalog.	Circle 23
WARREN ELECTRONIC COMPONENTS (Pg. 99) Information on silicon rectifiers.	Circle 125
WELLER ELECTRIC CORP. (Pg. 74) Information on Weller Dual Heat soldering guns and kits.	Circle 33
WINEGARD CO. (Pg. 95) Fact finder #242 with information on Winegard Chroma-Tel antenna.	Circle 122
XCELITE, INC. (Pg. 24) Bulletin N666.	Circle 20

NEW PRODUCTS

More information on new products is available free from the manufacturers of items identified by a Reader's Service number. Turn to the Reader's Service Card facing page 78 and circle the numbers of the new products on which you would like further information. Detach and mail the postage-paid card.

Hz = hertz = cycles per second; kHz = kilocycles; MHz = megacycles

COLOR TV COMPONENT, all-in-one component and color television screen. Component-type TV chassis incorporates 25-in. rectangular, rare-earth picture tube with audio takeoff for hi-fi or stereo in-



stallation, also own output & speaker. Front-panel earphone plug. Optional wireless remote control for TV set.—Clairtone Sound Corp., Ltd.

Circle 46 on reader's service card

100-WATT 2-WAY VHF-FM RADIO, model 60AT100. Current drain: 70 mA in standby. High-frequency crystal filter selectivity. Complete instant interchangeability between negative- and positive-ground 12-volt ignition systems. Instant-heat vacuum tubes in transmitter power circuits. Plug-in transistors. Hand-wired circuitry. Rf output 100 watts. Ex-



truded-aluminum cabinet, cylinder-type lock. Shock mounts in trunk or other location. Control unit mounts under dash, controls on front panel. Built-in PM speaker. Control head, microphone, whip antenna, power and control cables, circuit breaker, mounting hardware, crystal for single channel in 148-174-MHz range. May be equipped for dual-channel operation. Transmitter-receiver unit 12 $\frac{1}{2}$ x 15 $\frac{1}{2}$ x 7 in., 24 lb.—Aerotron, Inc.

Circle 47 on reader's service card

CB TRANSCEIVER, the *Bronco*. Eight channels, transistorized. For mobile operation. Channel-11 crystal installed. Carbon microphone, coil cord, mounting



bracket. Minimum output 3 $\frac{1}{2}$ watts from 5-watt rf power input. Frequency stability: .005%; modulation to -90%, +100%. Sensitivity: 1 μ v or less. Built-in automatic-noise-limiter circuitry. Channel selector; on/off, volume, squelch controls. 15 silicon transistors, 5 diodes. Vinyl-laminated metal cabinet. 2 $\frac{3}{4}$ x 5 $\frac{1}{2}$ x 8 $\frac{1}{4}$ in., 4 lb.—Regency Electronics, Inc.

Circle 48 on reader's service card



ELECTRONIC SIREN, MOBILE PA SPEAKER, the *HPR-75*. Weather-proof. Mounting bracket aircraft aluminum cast in one rigid piece, space for concealed wire connection. Metal parts corrosion-proofed, melamine enamel finish. Power: 75 watts. Impedance: 16 ohms. Frequency response: 275-8,000 Hz. Sound level: 127 dB measured 4 in. on axis, rated power. Dispersion: 100°. 8 $\frac{1}{16}$ -in. bell diameter, 8 $\frac{3}{4}$ in. deep. 7 lb.—Atlas Sound, Div. of American Trading and Production Corp.

Circle 49 on reader's service card

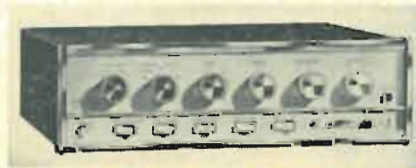

STEREO AMPLIFIER AND CONTROL CENTER, model S-9900a. Solid-state components, silicon transistors. Input facilities for tuner, phono, tape heads, tape monitoring, auxiliary sources. Can be used with highest output magnetic pho-

NEW From ALLIED *knight-kit*[®] Taut-Band VOM

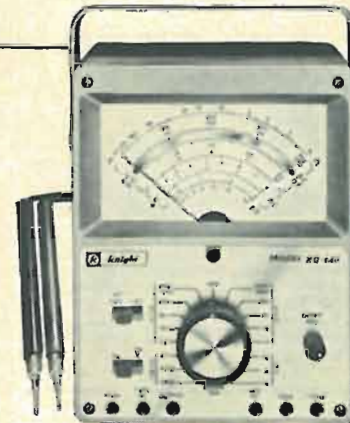

- Highly dependable, rugged Taut-Band meter movement assures repeatability of readings
- Total of 57 ranges . . . starts as low as .8 VDC full scale for easy and accurate transistor work
- Burnout-proof movement; no damage possible, even with 1000 times overload
- Mirrored scale and knife-edged pointer eliminate parallax errors for accurate readings

Here in an easy-to-build kit, at a surprisingly-low price, is the KG-640—20,000 ohms-per-volt VOM with a burnout-proof movement.

Covers 57 ranges for measuring AC, DC and Output volts, resistance, DC current and decibels. Rugged shock-resistant 50 μ a taut-band meter. The perfect instrument for testing radio and TV sets, hi-fi components, appliances, motors, house wiring, etc. Compact 6 $\frac{3}{4}$ x 5 $\frac{1}{4}$ x 3 $\frac{3}{4}$ " unit. Complete with batteries, test leads, as-
\$39⁹⁵
sembly manual for sale
Available factory assembled for \$59.95.

Backed by this unique money-back guarantee . . . exclusive in the industry:

KNIGHT-KIT GUARANTEE

Build a Knight-Kit in accordance with our easy-to-follow instructions. When you have completely assembled the kit, you must be satisfied or we will return your money, less transportation charges, under the Allied guarantee of satisfaction. **ALLIED RADIO**

Rush coupon today for full details and Special Introductory Offer.

ALLIED RADIO, Knight-Kit Div.
Dept. 2-MM, P.O. Box 8528, Chicago, Ill. 60680
Please rush full details and Special Introductory Offer on the new Knight-Kit Taut-Band VOM.

Name _____ Please print

Address _____

City _____ State _____ Zip _____

Circle 106 on reader's service card

Olson

FREE

Fill in coupon for a FREE One Year Subscription to OLSON ELECTRONICS' Fantastic Value Packed Catalog—Unheard of LOW, LOW PRICES on Brand Name Speakers, Changers, Tubes, Tools, Stereo Amps, Tuners, CB, Hi-Fi's, and thousands of other Electronic Values. Credit plan available.

NAME _____
 ADDRESS _____
 CITY _____ STATE _____ ZIP _____

If you have a friend interested in electronics send his name and address for a FREE subscription also.

OLSON ELECTRONICS, INC.

538 S. Forge Street Akron, Ohio 44308

Circle 107 on reader's service card

Because you've got to SEE it to BELIEVE it
 we will send you a FREE sample!

instant lettering®



DATAMARK

— the easy new way to label your projects!

Just rub over the pre-printed words or symbols with a ballpoint pen and they transfer to any surface—looks like finest printing! Label control panels, meter dials, letter on anything!

LOOK FOR *instant lettering*®

DATAMARK SETS only \$1.25 each
 — at leading electronic distributors

DATAMARK SETS AVAILABLE FOR:

- Amateur Radio, CB
- Audio, Hi-Fi, TV
- Experimenter Home Intercom
- Industrial Test Equipment
- Switch & Dial Markings
- Alphabets & Numerals in 1/8", 1/4" and 1/2"

— each set has black, white, and gold

SEND FOR FREE SAMPLE RE-4

THE DATAK CORPORATION
 85 HIGHLAND AVENUE • PASSAIC, N. J. 07055

Circle 108 on reader's service card

no cartridges; won't overload. Power output: music power 2 channels (4 ohms) 140 watts, (8 ohms) 100 watts; continuous power each channel (4 ohms) 50 watts at 0.6% distortion. Inverse feedback: 50 dB. Damping factor: 40:1 at 8 ohms. Frequency response: (40 watts) 20–20,000 Hz ±1 dB. Sensitivity: tuner 0.25 V., phono 1.6 mV, tape head 1.2mV. Max input capability: phono 250 mV for less than 1% distortion, tuner 2.8 V for less than 1% dist. Max hum noise: volume control (min) 90 dB; tuner input 80 dB; phono input 70 dB. Interchannel crosstalk: less than 45 dB at 1 kHz. 14 x 4 x 10 1/2 in., 22 lb.—Sherwood Electronic Laboratories, Inc.

Circle 50 on reader's service card

BEHIND-THE-EAR HEARING AID, model 72. Worn completely at the ear, transparent tube to eartip. Automatic telephone pickup with hum filter permits

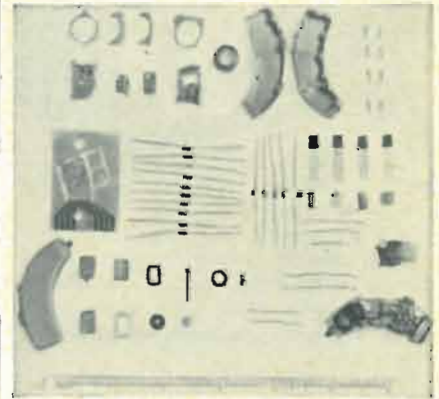

normal telephone use. Battery economizer allows maximum power when needed, idles when not needed. Silver 1 1/2-volt or mercury 1 1/4-volt battery. Mercury battery life: 80 hr. Direct-coupled temperature-compensated circuit, 4 silicon planar transistors, 9 resistors, 5 capacitors. Continuously adjustable separate volume control, 40 dB linear range. Removable battery holder with positive action on-off switch.—Sonotone Corp.

Circle 51 on reader's service card



VOM, the *Lab-Tester*, 100,000 ohms per volt. 6 1/2-in., 33-range meter, 2-color, full-range 90° arc; indicates exact range being used. Circuit design with 1/2% precision resistors, 100,000-ohms-per-volt input resistance on dc. Built-in protection against burnout and bent pointers. Ranges

ATTENTION! CB OPERATORS

save on citizens radio equipment

Discontinued Models From International Radio Exchange

Select that extra transceiver for mobile or base installation, or equip a new station. Our stock includes International types as well as other makes.

Write Today for A Complete List of Equipment in Stock



RADIO EXCHANGE
 18 NO. LEE, OKLA. CITY, OKLA. 73102
 Division Of International Crystal Mfg. Co.
 Dealing In Used Citizens Radio Equipment



Circle 109 on reader's service card

—dc: 0–5–2.5–10–50–250–500–1,000 V; ac: 0–3–10–50–250–500–1,000 V. DB: –10 to +49.4 in 4 ranges. Dc: 0–10–100 μ A, 0–10–100–500 mA. 0–2.5–10 amps. Resistance: 0–1K–10K–100K–10 megs–100 megs. Meter movement sensitivity: 9 μ A for full-scale deflection. Output range: to 250 V with built-in series capacitor.—Lafayette Radio Electronics Corp.

Circle 52 on reader's service card

DYNAMIC VISUAL VOLUME MONITOR provides means of seeing volume changes. Use of monitor, plus speaker-type monitors, gives closer control of audio sound system. Connects with phone plug to sound systems of various imped-



ances. Used with standard wattages. Indicates noises, hums, shorted speaker lamps, levels between projectors, or non-sync inputs. Minimizes dynamic distortion. Handwired circuits. 6 x 4 x 2 in.—Startronics Electronics

Circle 53 on reeader's service card

SPEAKER SYSTEM, model TSW-8s, the Troubador. Heavy-duty dual-cone speaker. Handles 15 watts of power. "Art frame" cabinet. Can be mounted in

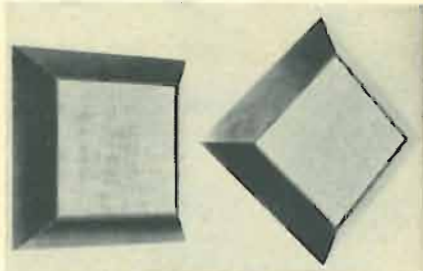

square or diamond position. Walnut or birch finish, linen grill cloth. 13 $\frac{1}{4}$ -in. square cabinet, 8-in speaker.—Argos Products Co.

Circle 54 on reader's service card



REGULATED POWER SUPPLY, model PZ-121. Solid-state, transistorized, Zener reference. Assembled or kit. Sta-

ble, continuously variable output from 0–15 volts dc; usable currents to 250 mA. Regulation: better than ± 0.2 V; ac ripple less than 5 mV for outputs to 100 mA. Burnout-proof circuitry; transformer-isolated output.—Viking Engineering of Minneapolis.

Circle 55 on reader's service card

STEREO-MONO CARTRIDGE, model 888E. 0.4 x 0.9-mil elliptical diamond stylus. For systems requiring higher tracking force than recommended for standard 0.2 x 0.9-mil stylus. Frequency response: 10–30,000 Hz. Output voltage:

BIG CATALOG
World's "BEST BUYS"
in GOV'T. SURPLUS
Electronic Equipment

FULL OF TOP QUALITY ITEMS—

Transmitters, Receivers, Power Supplies, Inverters, Microphones, Filters, Meters, Cable, Keys, Phones, Antennas, Chokes, Dynamotors, Blowers, Switches, Test Equipment, Headsets, Amplifiers, etc., etc. SEND 25¢ (stamps or coin) for CATALOG and receive 50¢ CREDIT on your order. Address Dept. RE.

FAIR RADIO SALES

P. O. Box 1105 • LIMA, OHIO • 45802

improves color reception
3 ways...

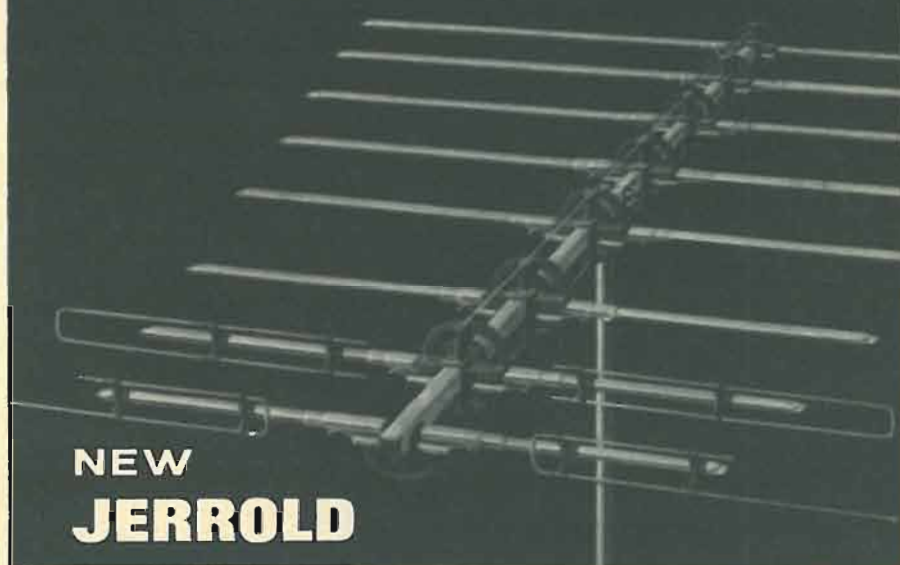

NEW
JERROLD

PARALOG Plus™

- 1. Plus GAIN**—provides sharper directivity to eliminate color ghosts.
- 2. Plus FLATNESS**—eliminates tilts which cause incorrect colors on the TV screen. Industry experts say that color antennas must be flat within ± 2 db. Paralog-Plus antennas are flat within ± 1 db per channel.
- 3. Plus MATCH**—to prevent color-distorting phase shifts.

To give you these *exclusive* color features Paralog-Plus has a unique Bi Modal Director system that actually works on high and low band channels simultaneously, making each element serve double duty.

What's more, you get a choice of 300 ohm and 75 ohm coaxial outputs, *plus* excellent gain over the entire FM band. For the greatest realism in lifelike color, try the Paralog-Plus.

JERROLD ELECTRONICS CORPORATION
DISTRIBUTOR SALES DIVISION
401 Walnut St., Phila., Pa. 19105

JERROLD

Circle 110 on reader's service card

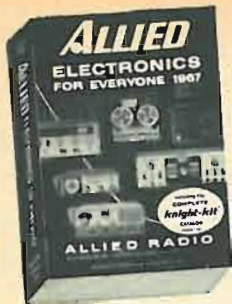

FREE

NEW 514-PAGE
1967
ALLIED
CATALOG

Top savings on the best
in electronics for everyone

SAVE MOST ON:

- Famous Knight-Kits
- Stereo Hi-Fi
- Tape Recorders & Tape
- CB 2-Way Radio
- Walkie-talkies
- FM-AM & AM Radios
- Short Wave & Ham Gear
- Portable TV & Phonos
- Intercom & P.A.
- Automotive Electronics
- Test Instruments
- TV Antennas & Tubes
- Power Tools, Hardware
- Tubes, Transistors
- Parts, Batteries, Books

Shop by mail and save at Allied, world's largest electronics headquarters. Hundreds of money-saving values, including fun-to-build Knight-Kits, and many specials available only from Allied. **NO MONEY DOWN!** 24 MONTHS TO PAY! Enjoy the things you want now, while you pay for them on the convenient Allied Credit Fund Plan.

Send for new 1967 ALLIED Catalog.

FREE!

ALLIED RADIO, DEPT. 2M
P.O. BOX 4398, Chicago, Ill. 60680

Send FREE 1967 ALLIED CATALOG

Name _____
PLEASE PRINT

Address _____

City _____ State _____ Zip _____

Enjoy the "music-only" programs
now available on the FM broadcast
band from coast to coast.

- NO COMMERCIALS •
- NO INTERRUPTIONS •



It's easy! Just plug Music Associated's Sub Carrier Detector into multiplex jack of your FM tuner or easily wire into discriminator. Tune through your FM dial and hear programs of continuous commercial-free music you are now missing. The Detector, self-powered and with electronic mute for quieting between selections, permits reception of popular background music programs no longer sent by wire but transmitted as hidden programs on the FM broadcast band from coast to coast. Use with any FM tuner. Size: 5½" x 9". Shipping weight approx. 7 lbs.

KIT \$4950

(with pre-tuned coils, no alignment necessary)

WIRED \$7500 (Covers extra \$4.95 ea.)

Current list of FM Broadcast stations with SCA authorization \$1.00

MUSIC ASSOCIATED

65 Glenwood Road, Upper Montclair, N. J.
Phone: (201)-744-3387 07043

Circle 116 on reader's service card

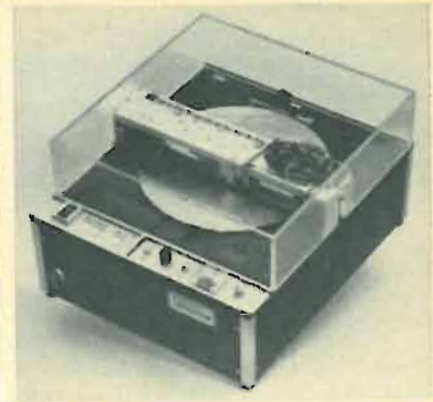

times. In model VDR-210CF (illustrated) recording medium is 3/16-in. thick aluminum 12-in. diameter disc with magnetically sensitive surface; designed for sports, news material. Other models for scientific and medical applications. Power requirements: 117 Vac, 200 W. Video channel: standard 1 V, composite input and output; 75 ohms terminated, unbalanced; input range adjustable from 0.5-1.5 V peak-to-peak. Outputs: 2 identical 75-ohm unbalanced sources, terminated; adjustable from 0.5-1.5 V peak-to-peak. Frequency response: ±3 dB from 10 Hz-3.8 MHz with respect to 1 MHz. Signal-to-noise: 40 dB or better, peak-to-peak video to rms noise. Transient response: rise time less than 0.2 μsec (10%-90%) on pulses measured with pulse inputs with 0.1-μsec rise time, overshoot less than 10%. Differential gain: less than 10%. Horizontal stability within FCC standards.—MVR Corp.

Circle 65 on reader's service card

STEREOPHONIC TAPE PLAYER
FOR AUTOMOBILES plays 4- and 8-track cartridges. Fully automatic operation.



Reject bar permits manual program selection, optional foot-switch control. Black and chrome front piece, 1½ x 7½ in. Fits under dash. Any 12-volt vehicle.—Tenna Corp. **END**

Circle 66 on reader's service card

LATEST and GREATEST!

NEW *Brack* UHF/VHF TV ANTENNAS FOR Black/White & Color



- Ultimate in Design!
- Unequaled in Performance!
- Outstanding in Value!

- 6651 Gold Finish
- 6652 Chrome Finish

Dept. Stores, Distributors & Television Manufacturers—Let us quote you on your PRIVATE BRAND requirements.

SEND FOR our latest catalog with our complete line of antennas

BRACH MFG. CORP.
Div. of General Bronze Corp.
899 Main Street, Sayreville, N.J. 08872

Circle 117 on reader's service card

What Industrial Switch Do You Use Almost Every Day?

Every time anyone dials a phone, he is using a "Rotary Stepping Switch." Factories use them for controlling production lines, and broadcast stations for adjusting transmitters. Learn all about them starting in January

RADIO-ELECTRONICS

CRYSTALS are not all the same!



**INSIST ON
TEXAS
CRYSTALS
BY NAME!**

If your dealer is temporarily out of stock or does not carry Texas Crystals, send us his name along with your request for catalog to our plant nearest you.

Texas Crystals quality is outstanding as evidenced by use in numerous government space projects where there's no compromise with quality, reliability or accuracy. The same dependable performance is yours for CB operation on all 23 channels at only \$2.95 per crystal.

Send for Free Catalog with Circuits

TEXAS CRYSTALS

A Division of Whitehall Electronics Corp.

1000 Crystal Drive 4117 W. Jefferson Blvd.
Ft. Myers, Florida Los Angeles, California
Phone 813 WE 6-2109 Phone 213 731-2258

Circle 118 on reader's service card

for your convenience

over
600
electronic
parts
distributors
now sell
Radio-Electronics
in the United States
and Canada

DECEMBER 1966

NEW LITERATURE

All booklets, catalogs, charts, data sheets and other literature listed here are free for the asking with a Reader's Service number. Turn to the Reader's Service Card facing page 78 and circle the numbers of the items you want. Then detach and mail the card. No postage required!

TRANSPORTABLE EARTH STATION brochure tells in detail the operation of the earth station used in Gemini 7/6 and 9, and outlines its possible future uses.—International Telephone & Telegraph Corp.

Circle 67 on reader's service card

RECTIFIER REPLACEMENT CATALOG, No. 66-DL-3, lists full line of standard replacement rectifier devices, also many designed especially for color TV.—Semiconductor Div., Sarks Tarzian, Inc.

Circle 68 on reader's service card

PARTS AND COMPONENTS CATALOG, Barry's Green Sheet. Features electronic tubes, semiconductors, transformers, chokes, meters, wire, test equipment. Contains many hard-to-find items.—Barry Electronics Corp.

Circle 69 on reader's service card

TONE SYSTEMS. Explains tone-alerting system operation for fire and civil defense companies. Illustrates how tone alerting works for small, medium and large emergency units. 16 pages—Regency Electronics, Inc.

Circle 70 on reader's service card

VIBRATOR REPLACEMENT GUIDE for communications and Citizens-band equipment. Contains a cross-index of communication vibrator manufacturers' numbers to Cornell-Dubilier replacements, an alphabetical listing of manufacturers' trade names showing Cornell-Dubilier replacement, and a section dealing with Citizens-band vibrator replacements. 8 pages.—Cornell-Dubilier Electronics Div.

Circle 71 on reader's service card

SOLDERING FINE COPPER WIRE, Bulletin TR 1018, 4 pages. Summarizes methods for overcoming difficulties in soldering, appropriate soldering procedures. Dip, wave, hand soldering of fine copper wire wrapped terminals. Areas of potential trouble outlined, suggested solutions.—Alpha Metals, Inc.

Circle 72 on reader's service card

1967 ELECTRONICS CATALOG, No. 260, 514 pages. All areas of electronics. Includes Knight-Kits, technical books, expanded listings on equipment for automobiles. Descriptions, illustrations, price lists. Index.—Allied Radio Corp.

Circle 73 on reader's service card

ALL-CHANNEL TV SHOWROOM DISTRIBUTION SYSTEMS BROCHURE, No. DS-C-017. 4 pages. Explains advantages of single-cable distribution systems carrying all vhf, uhf, FM programs. Describes function, circuitry of various systems, equipment required.—Jerold Electronics Corp. END

Circle 74 on reader's service card

NOW FROM DELTA

A Complete Automotive and Ignition Tune-Up System



MARK TEN
Capacitive Discharge
Ignition System
\$44⁹⁵ Assembled
\$29⁹⁵ Kit Form

Get mileage you never dreamed of! 3 to 10 times spark plug life. Instant starts in all weather. Installs in only 10 minutes. Up to 20% gas savings. Dramatic increase in engine performance and acceleration.

2 NEW AUTO TUNE UP INSTRUMENTS



DWELL
METER
\$12.95
Ppd.

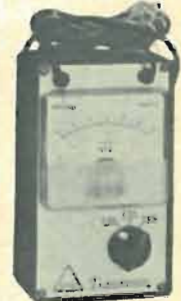

TACH
METER
\$14.95
Ppd.

These two new cousins to the world famous proven MARK TEN now give you the capability to tune your own car inexpensively, easily, with remarkable precision. These separate instruments are low cost, portable and the easiest to read you've ever seen.

- Delta's famous printed circuit design
- Superior in precision, quality and performance to instruments selling for FIVE TIMES as much
- Large dial, high quality jewel D'Arsonval meters
- Operates with standard, transistor or capacitive discharge systems as well as magnetos
- Instant readings — no confusing scales

Send Your Order Today



DELTA PRODUCTS, INC.

P.O. Box 1147 RE • Grand Junction, Colo.
Enclosed is \$_____. Ship prepaid.
 Ship C.O.D.

Please send:

- Dwell Meters @ \$12.95
 Tach Meters @ \$14.95
 Mark Tens (Assembled) @ \$44.95
 Mark Tens (Delta Kit) @ \$29.95

(12 volt positive or negative ground only)

SPECIFY — Positive Negative
 6 or 12 Volt

Car Year _____ Make _____

Name _____

Address _____

City/State _____ Zip _____

EP 8-61

Circle 119 on reader's service card

What you don't know about TV, Transistors & Test Instruments, may be costing you a promotion or a pay raise!

Here is an extraordinary offer to introduce you to Gernsback Library's famous Electronics Book Club, specially designed to help you increase your know-how and earning power.

WHY SHOULD YOU JOIN!

Whatever your interest in electronics—radio and TV servicing, audio and hi-fi, industrial electronics, communications, electronics as a hobby—you'll find that the Electronics Book Club will help you get the job you want, keep it, improve it, or make your leisure hours more enjoyable. By broadening your knowledge and skills, you'll build your income and electronics enjoyment as well.

WHAT BOOKS ARE OFFERED?

From Gernsback Library and other leading publishers come the country's most respected books in the field of electronics. All are deluxe, hard-covered books of permanent value, offered at considerable cash savings to members, regardless of higher retail prices.

HOW THE CLUB WORKS

The Electronics Book Club will send you, every other month, the News Bulletin describing a new book on a vital area of electronics. As a member, *you alone* decide whether you want a particular book or not. You get 3 books now for \$1.99 and need take only 4 more within a year, from a wide selection to be offered. And the Club *saves you money* on the books you take, regardless of higher retail prices.

HOW TO JOIN

Simply mail the coupon today. You will be sent your three handbooks—BASIC TV COURSE, FUNDAMENTALS OF SEMICONDUCTORS and THE OSCILLOSCOPE (regular retail price \$15.55). We will bill you \$1.99 (plus a few cents postage). If you are not pleased with the books, send them back within 10 days and membership will be cancelled. Otherwise you will enjoy these benefits:

- ★ Get three books immediately for \$1.99 (regular \$15.55 value).
- ★ Free 10-day examination privilege.
- ★ Continuous cash savings.
- ★ Free charts and reports given with many books.
- ★ You alone decide which books you want. Books are returnable.
- ★ Club Books are practical working tools, written by experts.

Get these three income-boosting books... a \$15.55 value

only **\$1.99**

by joining the Electronics Book Club today!

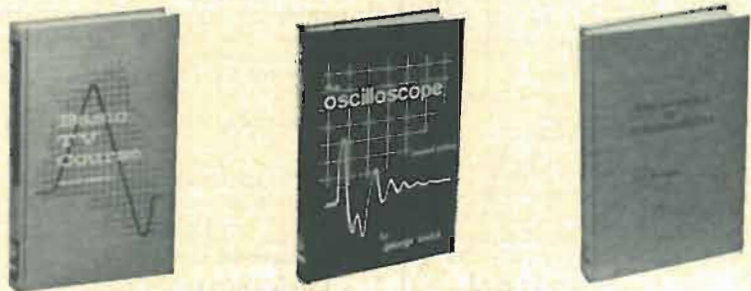

BASIC TV COURSE

By George Kravitz. Perfect introduction to TV, in clear, non-mathematical language. Starting with the forming of the picture, the book shows how the picture tube works, the television signal, the television receiver, antennas and tuners, how the video IF works, the video detector and AGC, the video amplifier at work, how the sync section works, horizontal output and high voltage supply, how the sound section works, how transistor portable TV's work. 224 pages, completely illustrated. Retail Price \$5.75.

FUNDAMENTALS OF SEMICONDUCTORS

By M. G. Scroggie. Provides a complete background in semiconductor devices, beginning with basic facts on electrical conduction through transistors, rectifiers, photoelectric devices, thermistors, varistors, diodes, cryosars, etc. Supplies enough theory in a simple way to make it possible to understand more advanced literature. Also explains how the special properties of semiconductors are being applied in many kinds of useful devices. Dozens of charts, diagrams and photos. 160 pages. Retail Price \$4.60.

THE OSCILLOSCOPE

By George Zwick. (Revised Edition). Teaches you how to operate the scope, how to use it for alignment and shows you how to solve every type of service testing problem you are likely to encounter. Demonstrates how to interpret waveforms correctly, how to use scope probes, how to measure low input voltages, how to perform specific experiments using the oscilloscope, etc. 224 illustrated pages. Retail Price \$5.20.

Gernsback Library, Inc., Electronics Book Club, Dept. RE 126

154 West 14th Street, New York, N.Y. 10011

Please enroll me in the Electronics Book Club and send me the 3 income-boosting handbooks: BASIC TV COURSE; FUNDAMENTALS OF SEMICONDUCTORS; THE OSCILLOSCOPE. Bill me only \$1.99 plus shipping (for this \$15.55 value). If not pleased, I may return the books in 10 days and this membership will be cancelled.

As a member, I need only accept as few as 4 additional books a year—and may resign any time after purchasing them. All books will be described to me in advance, every other month, in the Club Bulletin, and a convenient form will always be provided for my use if I do not wish to receive a forthcoming book. You will bill me the special Club price for each book I take (plus a few cents postage)—regardless of higher retail prices. Offer good in U.S.A. and Canada only.

Name (Please Print)

Address

City State Zip Code

SAVE: Enclose your \$1.99 now with this coupon and we will pay postage. Same return guarantee privilege; prompt refund if not satisfied.

1966 ANNUAL INDEX

RADIO-ELECTRONICS January-December 1966 of Vol XXXVII

ABC's of Color TV (Darr)	Aug 72
Abbreviations, Hertz adopted for	
Feb 12; (Corres)	May 16, Oct 14, Nov 15
Criticism (Corres)	Jul 10
Acousti-Lite Santa Claus (Blechman)*§	Oct 38
Add Sound to Home Movies (Shepard)	
Mar 46; (Corres)	May 22
Afternoon at CB Repair (Randall)	Apr 53
Alarms	
Lights-On Reminder for Your Car (Montan'e)*	Dec 53
Simple Silent (Lemons)*§	Nov 42
Aligning the FM Stereo Radio (Feldman)	Jul 44
All-Purpose Sub Box (Wortman)*§	Dec 50
All-Silicon Regulated Power Supply (Rogers) §	
Jun 54; (Corres)	Sep 16
All-Transistor Circuits for Chromatron Color (Sutheim)	Jun 48

AMPLIFIER(S)

Af, Selective, Boosts Receiver Performance (Queen)*§	Jan 54
Bias circuit (NC) Jan 100; (Corres) Mar 16,	Jun 14
ECL1800 tubes available	Jan 100
Headphone, Stereo (Riskind and Yasillo)*§	Mar 59
IHF Standard, What's in New (von Recklinghausen)	Mar 39
Power, solid-state (Dynaco Stereo 120)†	Nov 70
Seismic, Tops Out at 1 Hz (Hansen)*§	Sep 54
Simpli-fier (Balyoz)*§	Feb 37
Analyzing CB Failures (Rice and Mueller)	Sep 37
"And/Or . . . Nand/Nor" . . . Computer Talk (Math)	Sep 46
Another "Transistor Line Transformer" (Marston)*§	Jun 36

ANTENNA(S)

Ferrite, keep magnets away from (Tech)	Sep 97
Most mounting with only two hands (TTO)	Oct 98
Rotator (Alliance Tenna-Rotor)†	Oct 71
Test Clip (Dow)	Jun 66
Tower caddy, handy (TTO)	Oct 99
Transmitting, CB and Two-Way Radio (CI)	Sep 22
Are We Really Making Progress (Davis) (Corr)	Feb 16

AUDIO—HIGH FIDELITY—STEREO, see also Servicing, audio—high fidelity—stereo

Amplifier(s)	Jan 100
ECL1800/6KH8 tubes available	Mar 16
Bias circuit (NC) Jan 100; (Corres)	Mar 16
Headphone, Stereo (Riskind and Yasillo)*§	Mar 59
IHF Standard, What's in New (von Recklinghausen)	Mar 39
Power, solid-state (Dynaco Stereo 120)†	Nov 70
Simpli-fier (Balyoz)*§	Feb 37
Another "Transistor Line Transformer" (Marston)*§	Jun 36
Bias, Handy Way to Adjust (von Recklinghausen)	Oct 58
Bass Tones (Corres)	Apr 17
Colorgan (Lancaster)* (Corres)	Feb 16, Apr 16
Computer, Be! has hi-fi (NB)	Jan 4
Electronic Organs	
Chiff, what's a (CI) Sep 24; (Corres)	Dec 12
Colorgan (Lancaster)* (Corres)	Feb 16, Apr 16, Jun 12
Tuning (Erl'ich)	Feb 36
Unitone—Unijunction-Transistor Organ (Cleary)*§ Jun 43; (Corres)	Sep 16
Followers: cathode, Plate and Others (Crowhurst)	May 51
Go-Go Sound Man, How to Be a (Haskett)	Feb 46
Guitar	
Amplification in Atkins Style (Belt)	Nov 32
Thunderbox—50-watt Booster (Prewitt)*§	Nov 56
Handy Way to Adjust Bias (von Recklinghausen)	Oct 58
Home Movies, Add Sound to (Shepard)*	Mar 46; (Corres)
Jack, little work and no play makes (TTO)	Dec 96
Light Beam, Talk Over a Hi-Fi (McCarty)*	Apr 34
"Line Transformer" (Sutheim)*§	Apr 40
"Line Transformer, Transistor," Another (Marston)*§	Jun 36

KEY TO SYMBOLS AND ABBREVIATIONS

* Construction Articles	
† Section of full-length article	
§ Transistorized	
CI Service Clinic	
Corr Correction	
Corres Correspondence	
NB News Briefs	
NC Noteworthy Circuits	
Tech Technotes	
TTO Try This One	
WN What's New	
Regular departments not itemized are New Books, New Literature, New Products, What's Your EQ?	

PA

Custom Equalization Enhances Sound (Davis)	Nov 44
Load, High-Power (Kernin)*	Mar 78
Load, Make a High Power	
More precise audio load (TTO)	Aug 88
Mike Preamp for (Pugh)*§	Feb 92
Quick-Change System Saves \$\$ (Darragh)	Sep 44
Preamp—Solid-State and High-Z Too (Wherry)*§	Nov 47
Record Changers and Players	
Record-level control, automatic (NC)	Sep 106
Removing the Mystery from Matching (Crowhurst)	Dec 56
Variable Speed for Tapes and (DiElsi)*	Mar 57
Speakers and Enclosures	
AR-2a* (Acoustic Research)† Jan 67; (Corr)	Mar 100
Long Ones, Short Ones, Fat Ones, Tall Ones (Augsburger)	Jan 55
Matching, Removing the Mystery from (Crowhurst)	Dec 56

Stereo

Amplifiers	
C O P 30/30 (DeSa)*§	Jul 48
Mattes SSP-200†	Jun 62
Power, solid-state (Dynaco 120)	Nov 70
Center channel for (NC) (Corres)	Mar 16
Controls and You (Fred)	Mar 76
Headphone Amplifier (Riskind and Yasillo) §	Mar 59
Receiver, FM—(Heathkit AR-14)†§	Jul 65
Sound for TV, a Report (Leslie)	Nov 61
Stations, U.S. and Canada, FM	Jul 41, Nov 100
System (Harman-Kardon SC-440)†	Jun 60
Tuner	
FM, KLH 18†	Feb 69
FM, World's Most Expensive (Sutheim)	Jul 30
Talk Over a Hi-Fi Light Beam (McCarty)*	Apr 34
Tape Players and Tape Recorders	

Battery

Sony-Matic TC-900†	Mar 66
Spring Roundup of Mar 42; (Corres)	Jun 12
Cartridge(s)	
Auto, standards set up tentatively (NB)	Jul 8
Auto Tape Players (Darr)	Nov 38
Standardized with "Musiccassette" sys'em? (NB)	Sep 4
Standards set up tentatively? (NB)	Jul 8
For soldiers in Viet Nam (NB)	May 12
Four-track stereo (Knight KG-415)†	Mar 69
Long Life for Your Tapes (Smith)	Mar 90
Roundup, Spring, of Battery	Mar 42
Stereo (ReVox G-36)†	Mar 71
Tape-splicing block (Editall KP-2)†	May 62
24 Ways to Put to Work (Blechman)	Mar 34
Variable Speed for Records and (DiElsi)*	Mar 57
Transistors, field-effect, in hi-fi systems (NB)	Dec 4
Tuner, FM stereo (KLH 18)†	Feb 69
Turnable	
Dual 1019 Auto/Professional†	Apr 67
Lab 80 (Garrard)†	Jan 70
Wider the Band, Higher the Fi? (Brociner vs Furst) Mar 50; (Corres)	Jun 53

Audio Voltmeter for Lab and Shop (Hansen)*§	Jul 10
Mar 36; (Corres)	

AUTOMOBILE

Analysis, New Twist in Accurate Automotive (Smith)	Dec 32
Analyzer (Eico 888)	Dec 70
Electronic System to Guide Tomorrow's Cars (Faulstich)*§	Dec 39
Ignition, Electronic	
Adapter for transistor ignition (NC)	Dec 98
Capacitor-Discharge System (Gerald)*§	Feb 34
Cold-Start Circuits for Transistor (Baker)	Mar 56
20 Keys to (Salzberg)	Jun 33
Zenerless (King)*§ (Corres)	Jul 16
Lights-On Reminder for Your Car (Montan'e)*	Dec 53
Radio (see also Servicing, radio)	
Heavy-Duty 5-Amp Supply—With Regulation (Crowell)*§	Sep 59
Mobilize Your Transistor (Pugh)*§	Dec 42
Squelch, Do You Understand? (Lenk)	Dec 44
They said it couldn't be done (TTO)	Jan 95
Understanding FM (Rice)	Nov 58
Storage battery, new, could bring back electric autos	Dec 77
Tachometer	
Dwellmeter, Simplest (Sweet)*	Aug 44
Reliable (Gross)*§ (Corres)	Feb 14
Tape	
Cartridge standards set up tentatively (NB)	Jul 8
Players (Darr)	Nov 38
(NB)	Jul 8
Temperature, outside, indicator (WN)	Mar 49

B

Battery	
Eliminator for 9-volt sets (NC)	Jun 98
Holder (TTO)	Jul 76
Clothespins as (TTO)	Jun 96
Lectrocell for Health vivim's (TTO)	Dec 96
Recorders, Spring Roundup of, Mar 42; (Corres)	Jun 12
Storage, new, could bring back electric autos	Dec 77
Undersea atomic, to operate 5 years (NB)	Oct 6
Busy-Box—Thinking Tot's Toy (Tiso)*, telephone dials for	Mar 53

C

Capacitor Codes, How to Read (Clifford)	May 58
Capacitors, Zeners as Hi-Cap Variable (Turner)	Sep 36
Career Series	
Installers (Thrower)	Oct 41
Microwave, Your Future in (Thrower)	May 40
Military Electronics Specialist Gap (Pursglove)	
Jul 35; (Corres)	Nov 14
Two-Way Radio Technician (Darr)	Apr 36
Case of the	
Missing High Voltage (Fred)	Apr 55
Open Cathode Resistor (Chamkis)	Apr 61
CB'ers Crystal Calibrator (Greenlee)* Sep 52; (Corres)	Nov 16
CB Radio, see Radio, CB	
Chassis material, inexpensive (TTO)	Dec 96
Chroma Trouble Chart (Darr)	Jan 36
Chromatron, Whatever Became of the (Sutheim)	Jan 40
Circuit Quiz (Moss)	Jun 45
Cold-Start Circuits for Transistor Ignition Systems (Baker)	Mar 56
Color A/c Adjustments Are Really Simple (Darr)	Dec 46
Colorgan (Lancaster)* (Corres) Feb 16, Apr 16, Jun 12	
Color, How We See (Leslie) Jan 34; (Corres)	Mar 16
Color television, see also Servicing, Television, color; Television	
Color Television Systems: Which Way Will Europe Go? (Leslie) Jul 68; (Corres)	Sep 16; (Corr)
Oslo splits on (NB)	Nov 12
	Oct 4

Hospital communications systems, new (NB)	Feb 4	Kids and low-power sets give FCC	Mar 4
Keeping eye on operation (WN)	Mar 49	troubles (NB)	Sep 34
Muscle Stimulator, Solid-State (Breskind)*§	July 10	Let the Lasers Do the Talking (Belt)	May 57
(Corres)		Making Modulation Easy to Understand	Sep 48
"Speed Hear" recordings, harmonic	Feb 6	(Crowhurst)	May 57
compressor makes (NB)	Jan 14	Mobile Transmitter Notes (Loper)	Jul 90
Stethoscope, mike for electronic (Corres)	Feb 39	Squelch	Dec 44
Wheelchair electronically controlled		Add diode (NC)	Jul 90
Metal Locators		Do You Understand? (Lenk)	Dec 44
Finding Buried Stuff (Beeler)	Apr 42	Troubleshooter's Casebook (Mueller)	Sep 92, Dec 73
Metal-Finder, Summer Fun with a		TV channels for paging? (NB)	Oct 6
Sensitive (Gill)*§ Jul 55; (Corr)	Oct 77	User sentenced to jail (NB)	Feb 12
Underwater Metal Hunting for Fun and		What VSWR Can Do to Your Communications	Jul 40
Profit (Klippberg)*§ Jun 38; (Corres)	Sep 14	(Pippen)	Mar 61
Microwaves, higher-power, with simple	Feb 6	Wireless Intercom Is Transceiver (Scott)	Mar 61
devices (NB)		Xtal + Oscillator = Citation?? (Connelly)	Sep 42
Microwave, Your Future in (Career Series)	May 40	Europe on broadcast band again (NB)	Jan 4
(Thrower)		FCC examinations revised (NB)	Apr 12
Military Electronics Specialist Gap (Career		5.5-mc TV sound, how to hear (Corres)	Jan 14
Series) (Pursglove) Jul 35; (Corres)	Nov 14	Ham operator, world "medico" record set by	Dec 72
Mixwell Theory, or Drinks Under the "Counter"	Feb 52	How to Get Something for Nothing, Almost	Feb 42
Mobile Transmitter Notes (Loper)	May 57	(Geisler) (Corres)	Jan 13
Mobilize Your Transistor Radio (Pugh)*§	Dec 42	Interference control act may come in '66 (NB)	Dec 42
Motors, reversing dc (NC)	Feb 102	Portable	Dec 42
Multi-Alarm (Schauers)*§	May 44	Mobilize Your Transistor (Pugh)*§	Jul 51
		Soup Up Your All-Band Transistor (Shields)	Mar 17
		Transistorize Your Tube (Pugh)*§ (Corr)	Mar 12
		Mar 100; (Corres)	May 80
		Satellite-to-home, being studied by NASA	May 38
		(NB)	Feb 4
		Stereo, see Audio—High Fidelity—Stereo	Jan 45
		Touch Tuning, Lowdown on (Scott)	Feb 60
		Transistor, Zener Power Supply for (Moss	Nov 4
		and Beville)*	May 38
		Tubes not done for (NB)	Mar 4
		Tuner, Improvement for Heathkit Multiplex	Sep 16
		Turn-on, Fast, for Vacuum-Tube Radios	Jun 98
		(Bonin)	Jul 90
		WWV moves to Colorado (NB)	Nov 102
		Zener Power Supply for Transistor (Moss	Oct 59
		and Beville)*	Feb 94
		Radio astronomers have own whodunit (NB)	Dec 56
		Regulated power supply	Jan 50
		All-Silicon (Rogers)*§ Jun 54; (Corres)	Jun 40
		Short-circuit protection (NC)	Aug 53
		Relay(s)	Jul 60
		Audio switching (NC)	Sep 58
		Service aid, magnifier as (TTO)	Nov 106
		Simple Electronic (Neale)*	Jan 42
		Special Tricks with (Ives)	Mar 42
		Removing the Mystery from Matching	Dec 49
		(Crowhurst)	Oct 38
		Repairing, see also Servicing	Oct 4
		Record Changers (Davidson)	Dec 4
		Solid-State Phonos (Davidson)	Dec 4
		Resistor and Capacitor Decades, Making Up	Sep 4
		(Dorsey)	Nov 4
		Restoring Middle-Aged CTC's (Darr)	Aug 60
		Rf Wattmeter for Uhf (Balyoz)*	Apr 38
		Rheostat, transistor power (NC)	Mar 22
		Roundup	Nov 50
		of 1966 Color Receivers	Sep 54
		Spring, of Battery Recorders	Oct 50
			Jan 54
			Dec 54
			Aug 4
			Mar 4
			Oct 59
			Jul 77
			Sep 98
			Apr 90
			Jun 66
			Sep 98
			Mar 25
			Mar 26
			Jun 12
			Feb 36
			Dec 97

4 easy ways to increase your know-how on microelectronics and solid state!

How to Build Tiny Electronic Circuits

By *Morris Moses*. Explains "miniaturized" electronics to the hobbyist, experimenter and service technician. Not only takes the mystery out of "making it smaller", but is a veritable "how to do it" of electronic miniaturization. Covers sub-miniaturization, microminiaturization, high-frequency receiver, molecular electronics, meter amplifiers, tone generators, semiconductor thermometers, making tools, preamplifiers, comparators, pocket radios, photorelays, components, techniques, modules, practical projects and devices, construction and repair hints. 192 pages.

Order #117 Softbound \$4.15

Getting Started With Transistors

By *Louis E. Garner, Jr.* Transistor know-how begins with this volume. Shows how transistors began, how to read electronic diagrams, how transistors work, facts on oscillators, transistor types, diodes, phototransistors, rectifiers, transistor ratings, testing transistors, Excellent text, diagrams and photographs carry you through every phase of transistors to give you a complete grasp of the subject. 160 pages by an expert in the field.

Order #116 Softbound \$3.95

Fundamentals of Semiconductors

By *M. G. Scroggie*. Provides a complete background in semiconductor devices, beginning with basic facts on electrical conduction through transistors, rectifiers, photoelectric devices, thermistors, varistors, diodes, cryosars, etc. Supplies enough theory in a simple way to make it possible to understand more advanced literature. Also explains how the special properties of semiconductors are being applied in many kinds of useful devices. Dozens of charts, diagrams and photos. 160 pages.

Order #92 Softbound \$2.95

Printed Circuits

By *Morris Moses*. Build-it-yourself circuits for miniature amplifiers, receivers, and many other transistor devices. Written especially for the radio ham, TV and radio service technician, and the home experimenter. Specializes in practical techniques and methods. Shows how to repair printed-circuit and subminiature assemblies. 224 pages jam-packed with illustrations.

Order #81 Softbound \$2.90

Order from your Parts Distributor or Mail to:

Gernsback Library Inc., Dept. RE 126
154 West 14th Street, N.Y., N.Y. 10011

Please send the following books. I enclose \$.....

117 (\$4.15) 116 (\$3.95)

92 (\$2.95) 81 (\$2.90)

Prices 10% higher in Canada.

Name

Address

City State Zip

My Distributor is



Where's the first place to look for electronic ideas? See the Gernsback book rack at your local parts distributor for facts, tips, hints, answers & know-how!

When you need professional help on tough electronics problems, go directly to the Gernsback Library Book Rack at your favorite electronics parts distributor. Here you'll find answers on radio and TV servicing, transistors, hobby projects, test instruments, audio, hi-fi, stereo, tape recording, communications, industrial electronics, to name just a few areas. Each book is designed to give you practical assistance in the field you desire. Examine the recent titles below.



New Skill-Building Transistor Projects and Experiments

By Louis E. Garner, Jr. This unusual handbook helps you discover everything about transistors by actually doing things with transistors. Shows how to conduct experiments to gain new facts and prove key points. You'll assemble your own circuits, make your own tests, draw your own conclusions based on the knowledge you've acquired. Projects include: headphone amplifier, hi-fi preamplifier, power megaphone, cigar-box portable, electric eye, rain alarm, etc. 192 value-packed pages.

Order #129 Softbound \$2.95



Color TV Repair

By 10 Servicing Experts. Top technicians like David R. Anderson, Ed Bukstein, Jack Darr, Homer L. Davidson, Art Margolis, Robert Middleton and Warren Roy have created here an important tool for the profit-minded service technician. Tells you clearly and concisely just what can go wrong in color TV receivers and how to fix them. First each trouble symptom is described in detail, then a perfect solution is provided for the problem. Book covers color circuits. ABC's of color TV servicing, antennas and boosters, replacing the color picture tube, how to pinpoint the defective color section fast, servicing the chroma circuits, unexpected causes of TV color failure, troubleshooting with a color bar generator, color servicing tips, plus a glossary of color TV terms. 106 pages.

Order #123 Softbound \$2.95

Servicing AGC Circuits

By Harry E. Thomas. This practical how-to-do-it manual first shows you everything that can go wrong with AGC circuits and then goes on to reveal all you need to know to correct the trouble. Enables you to locate breakdowns quickly in AGC circuits, and then make your repairs rapidly and intelligently. Specific service approaches are plainly spelled out so you can use them immediately. Special emphasis is placed on TV troubleshooting, giving you the devices and techniques used in modern circuitry. Easy-to-read explanations, helpful illustrations. 204 pages, available through parts jobbers only.

Order #126 Softbound \$3.95



Probes for Test Instruments

By Bruno Zucconi and Martin Clifford. A probe is a link. It is a device you connect between a test instrument like a scope or v.t.v.m. and a radio or TV set being repaired. The finest scope or v.t.v.m. is limited by the kind of probe you use, and by how much you know about putting probes to work for you. Now comes this valuable handbook showing you in clear detail exactly what probe to use for a particular job. Covers crystal-demodulator probes, voltage-doubler probes, balanced probes, low-capacitance probes, high-voltage probes, isolation probes, direct probes, specialized probes, vacuum-tube and semiconductor probes. 224 pages, newly revised.

Order #54 Softbound \$2.50

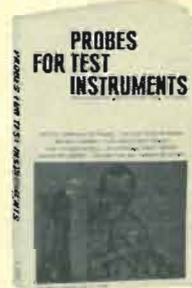

The Handbook of Electronic Tables

By Martin Clifford. Here is an effective new approach to solving electronics problems. You don't have to make mathematical computations, or carry a slide rule or memorize any formulas whatsoever. Every answer you will ever need is worked out for you in 160 fact-packed pages of accurate electronic tables. Simply take the figures of your electronics problems and turn to the appropriate table. Then move your finger across the table and read the answer, instantly. You'll find these tables are easy to use, offer a wide choice of solutions and provide a high degree of accuracy.

Order #125 Softbound \$2.95

Get These Books At Your Parts Distributor or Mail This Coupon

Gernsback Library, Inc., Dept. RE 612
154 West 14th Street, New York, N.Y. 10011

Please send the books checked below. I enclose \$.....

(Prices 10% higher in Canada)

129 (\$2.95) 123 (\$2.95)
 54 (\$2.50) 125 (\$2.95)

Name

Address

CityState.....Zip.....

My Distributor is

WHAT'S YOUR EQ?

These are the answers.

Puzzles are on page 52.

Black Box

The 45-volt battery alone won't cause the neon lamp to fire. With S open, the capacitor charges to 45 volts

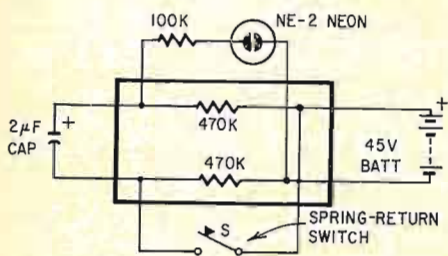

through the two 470K resistors. When S is closed, the capacitor is in series with the battery, and the 90-volt sum appears across the NE-2, which fires.

Switching Circuit

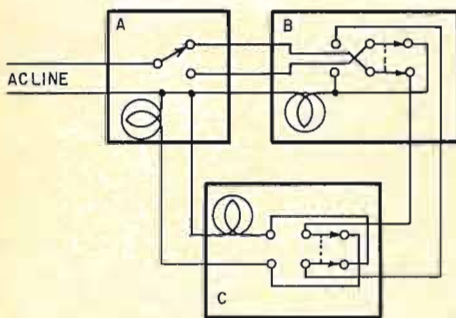

Switches are wired as shown. END

RADAR "SIGNATURES" TO IDENTIFY SATELLITES

A list of radar "signatures" of satellites is being compiled by cooperating Government and commercial groups. It will be used to aid in identifying and defining the purpose of unknown satellites. Radar signature analysis (RSA) is a new subsistence developed especially for that purpose.

A satellite's radar reflections, according to Charles Brindley of RCA's

Missile and Surface Radar Division, can tell scientists whether it is manned or unmanned, whether tumbling, rolling, spinning or stabilized, as well as give a fair approximation of its size and shape. This information, combined with knowledge gained from direct observation, can often give an idea of the satellite's purpose.

A list of signatures of satellites whose characteristics are known is of course a great aid in interpreting the "handwriting" of unknown satellites. However, interpretation by the human expert takes time, and rapid identification of an unknown satellite might be extremely valuable in some cases. Therefore, RCA is developing techniques to transfer the RSA catalog to a computer memory, to save the time spent by a human searcher in thumbing through a list and comparing signatures. The "automatic interface" between reception and reaction would be decisive in antimissile discrimination, since it might be vital to separate real warheads from decoys in a matter of seconds.

"Self-healing" solar cells may be 50 times as resistant to radiation as the ordinary type. Developed by RCA, they contain extra floating atoms of lithium, which flow into and "plug" any damaged areas. The cells cannot stand unlimited radiation, but could probably operate safely in the Van Allen belt.

Meet Winegard Chroma-Tel

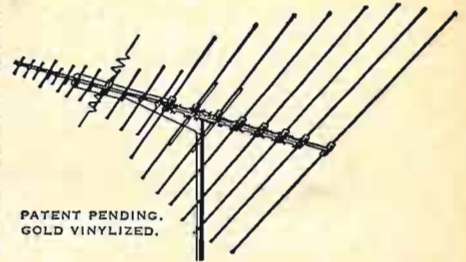

PATENT PENDING.
GOLD VINYLIZED.

First 1/2 size all-band (UHF, VHF, FM) antenna with full size power

- Delivers Brilliant Color, Beautiful Black and White, Full-Tone FM Sound
- Brings in All the UHF, VHF and FM Stations in Your Area

Now there's an All-Band (UHF, VHF, FM) antenna that is actually half the size of most other all-band antennas. It eliminates half the bulk, half the truck loading, half the storage space, half the wind space and half the weight of ordinary all-band antennas... without sacrificing one bit of performance! Features Winegard's new Chroma-Lens Director System and impedance correlators.

Compare size, cost and performance... you'll choose Winegard Chroma-Tel every time. Ask your distributor or write for Fact-Finder #242 today.

3 Models from \$17.50 list.

Winegard Co. ANTENNA SYSTEMS

3000 Kirkwood • Burlington, Iowa

Circle 122 on reader's service card

ELECTRONICS

Engineering-Technicians

Bachelor of Science Degree, 30 Months
Save Two Years' Time

- Radio-Television Plus Color Technician (12 Months)
- Electronics Engineering Technology (15 Months)
- Electronics Engineering (B.S. Degree)
 - Electrical Engineering (B.S. Degree)
 - Mechanical Engineering (B.S. Degree)
 - Civil Engineering (B.S. Degree)
 - Architecture (B.S. Degree)

Approved for Veterans

DAY AND EVENING CLASSES

Write for Catalog and Registration Application.
New Term Starting Soon.

Your Name
Address
City
State



The Nation's increased demand for Engineers,

Electronic Technicians, Radio TV Technicians is at an all time high. Heald Graduates are in demand for Preferred High Paying Salaries. Train now for a lucrative satisfying lifetime career.

HEALD'S

ENGINEERING COLLEGE

Est. 1863-103 Years
Van Ness at Post, RE 1266
San Francisco, Calif.

Circle 123 on reader's service card

the International MO-23 citizens radio transceiver hides...

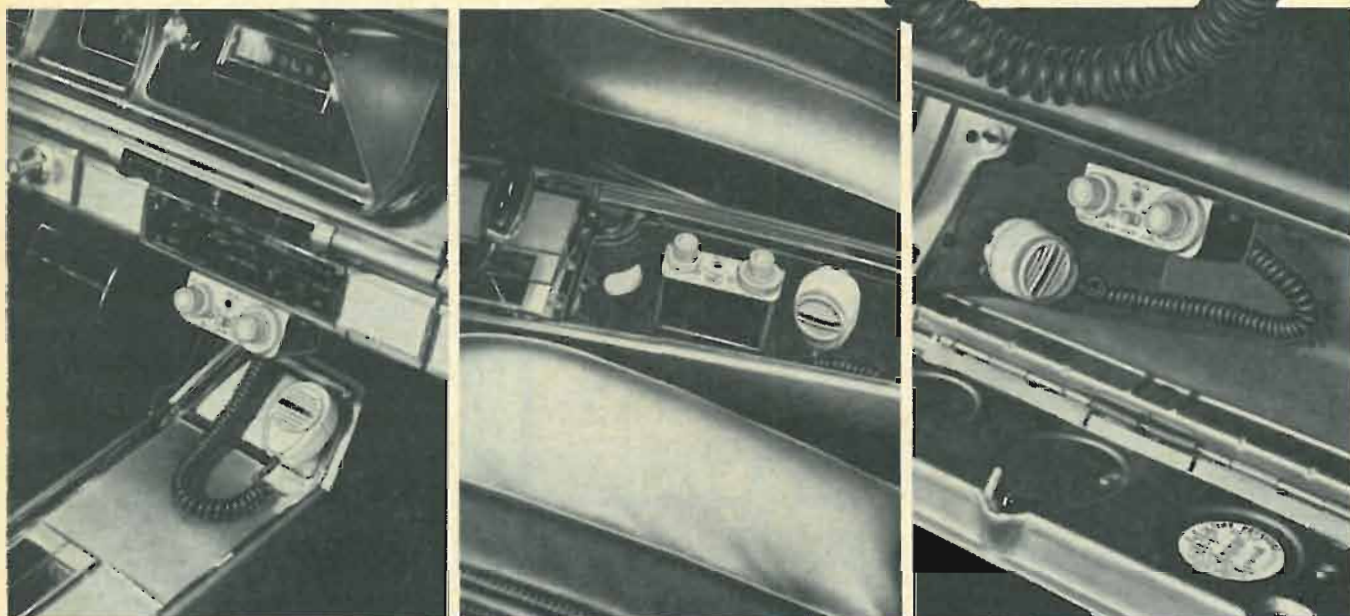

under the dash in the console in the glove compartment

The MO-23 remote control unit is so small it will rest on the palm of your hand (1½" H x 4" W x 2½" D). You can install the MO-23 under the car dash . . . in the glove or console compartment. Compare this versatile mobile two-way radio with other makes. See for yourself how little space this unit really requires. Technically speaking, the MO-23 combines the best advantages of tubes and silicon transistors.

CHECK THESE FEATURES:

- 23 Crystal Controlled Channels
- Miniature Solid State Remote Control
- Illuminated Channel Selector
- Transmit/Receive Trunk Unit
- Transistor Power Supply

Ask your dealer to show you the International MO-23. We think it's a great new transceiver. You will too!

**WATCH FOR INTERNATIONAL "FLYING SHOWROOM '66".
WELCOME ABOARD!**

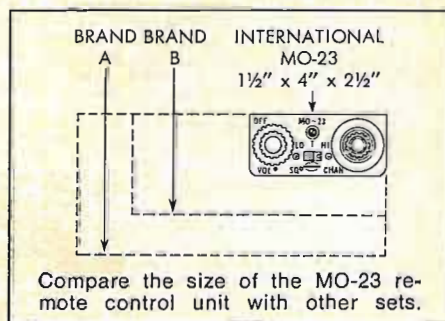

FCC Citizens Radio license required. All use must conform with Part 95, FCC Rules and Regulations.



CRYSTAL MFG. CO., INC.
18 NO. LEE · OKLA. CITY, OKLA. 73102



Introducing EICO's New "Cortina Series"!

Today's electro-technology makes possible near-perfect stereo at moderate manufacturing cost: that's the design concept behind the new EICO "Cortina" all solid-state stereo components. All are 100% professional, conveniently compact (3 1/8" H, 12" W, 8" D), in an esthetically striking "low silhouette." Yes, you can pay more for high quality stereo. But now there's no need to. The refinements will be marginal and probably inaudible. Each is \$89.95 kit, \$119.95 wired.

Model 3070 All-Silicon Solid-State 70-Watt Stereo

Amplifier: Distortionless, natural sound with unrestricted bass and perfect transient response (no inter-stage or output transformers); complete input, filter and control facilities; failure proof rugged all-silicon transistor circuitry.

Model 3200 Solid-State FM/MPX Automatic Stereo Tuner: Driftless, noiseless performance; 2.4µV for 30db quieting; RF, IF, MX are pre-wired and pre-tuned on printed circuit boards — you wire only non-critical power supply.

7 New Ways to make Electronics more Fun!

Save up to 50% with EICO Kits and Wired Equipment.



You hear all the action-packed capitals of the world with the NEW EICO 711 "Space Ranger" 4-Band Short Wave Communications Receiver — plus ham operators, ship-to-shore, aircraft, Coast Guard, and the full AM band. 550KC to 30MC in four bands. Selective, sensitive super-het, modern printed circuit board construction. Easy, fast pinpoint tuning: illuminated slide-rule dials, logging scale; "S" meter, electrical bandspread tuning, variable BFO for CW and SSB reception, automatic noise limiter. 4" speaker. Headphone jack. Kit \$49.95. Wired \$69.95.



More "ham" for your dollar than ever — with the one and only SSB/AM/CW 3-Band Transceiver Kit, new Model 753 — "the best ham transceiver buy for 1966" — Radio TV Experimenter Magazine. 200 watts PEP on 80, 40 and 20 meters. Receiver offset tuning, built-in VOX, high level dynamic ALC, silicon solid-state VFO. Unequaled performance, features and appearance. Sensationally priced at \$189.95 kit, \$299.95 wired.



NEW EICO 888 Solid-State Engine Analyzer

Now you can tune-up, troubleshoot and test your own car or boat.

Keep your car or boat engine in tip-top shape with this completely portable, self-contained, self-powered universal engine analyzer. Completely tests your total ignition/electrical system. The first time you use it — just to tune for peak performance — it'll have paid for itself. (No tune-up charges, better gas consumption, longer wear) 7 instruments in one, the EICO 888 does all these for 6V and 12V systems; 4, 6 & 8 cylinder engines.

The EICO 888 comes complete with a comprehensive Tune-up and Trouble shooting Manual including RPM and Dwell angle for over 40 models of American and Foreign cars. The Model 888 is an outstanding value at \$44.95 kit, \$59.95 wired.



New EICOCRAFT® easy-to-build solid-state electronic TruKits® great for beginners and sophisticates alike. As professional as the standard EICO line — only the complexity is reduced to make kit-building faster, easier, lower cost. Features: pre-drilled copper-plated etched printed

circuit boards; finest parts; step-by-step instructions; no technical experience needed — just soldering iron and pliers. Choose from: Fire Alarm; Intercom; Burglar Alarm; Light Flasher; "Mystifier"; Siren; Code Oscillator; Metronome; Tremolo; Audio Power Amplifier; AC Power Supply. From \$2.50 per kit.



There's more PUNCH in the new EICO "Sentinel-Pro" 23-channel Dual Conversion 5-watt CB Transceiver. New advanced Big-Reach "Range Plus" circuitry lengthens "talk-power" reach. Automatic noise limiter super-sensitizes for weak signals. "Finger Tip" antenna loading and transmitter tuning controls. 23 crystal-controlled transmit and receive channels — all crystals supplied. Rear-illuminated S/R/F meter. Transistorized 12VDC and 117VAC dual power supply. Wired only, \$169.95. Positive-Negative Ground/Mobile Marine Modification kit (optional \$5.95).



Model 460 Wideband Direct-Coupled 5" Oscilloscope. DC-4.5mc for color and B&W TV service and lab use. Push-pull DC vertical amp., bal. or unbal. input. Automatic sync limiter and amp. \$99.95 kit, \$139.50 wired.

FREE 1967 CATALOG

EICO Electronic Instrument Co., Inc. RE-12
131-01 39th Ave., Flushing, N. Y. 11352

Send me FREE catalog describing the full EICO line of 200 best buys, and name of nearest dealer. I'm interested in:

- test equipment
- stereo/hi-fi
- automotive electronics
- ham radio
- Citizens Band radio

Name _____
Address _____
City _____
State _____ Zip _____



Model 232 Peak-to-Peak VTVM. A must for color or B&W TV and industrial use. 7 non-skip ranges on all 4 functions. With exclusive Uni-Probe.® \$29.95 kit, \$49.95 wired.

PALMERI 1050

28 GEN. 1967

RCA's COLOR TV FASTCHECK #5



Got a **H.O.T.*** Problem?

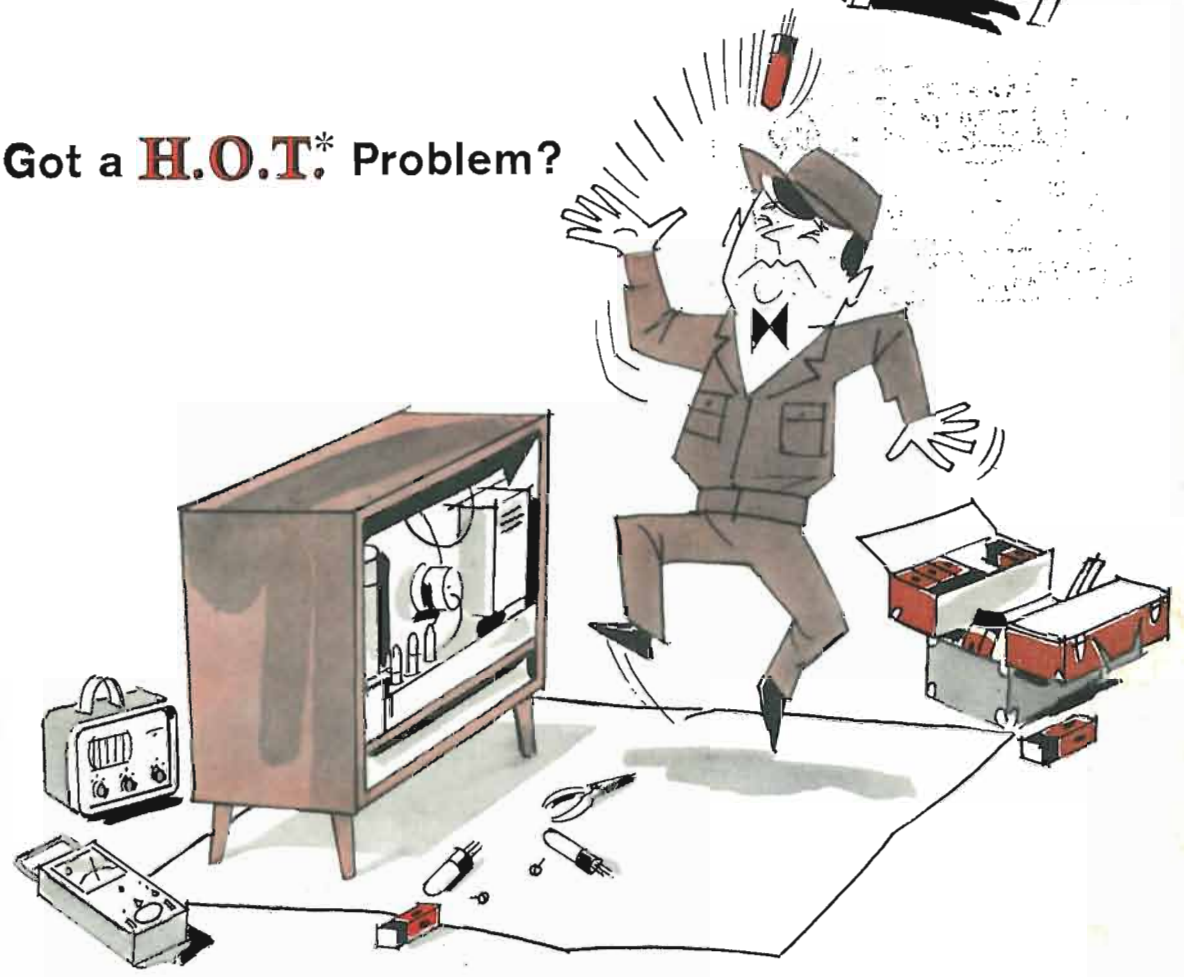

Keep it cool...and avoid burnout!

The *Horizontal Output Tube in a color set has to work hard...and efficiently. Abnormal circuit conditions can send its plate dissipation far beyond the allowable limit and permanently damage the tube.

The most likely source of damage is failure or removal of grid circuit drive for even 10 to 20 seconds. When servicing horizontal oscillator and deflection circuits, therefore, observe these "don'ts."

1. *Don't* pull the horizontal-oscillator tube with power applied to the set.
2. *Don't* apply power to a "warm" set if the oscillator tube is cold. Wait a few minutes, or heat the oscillator tube in a tube tester.
3. *Don't* risk H.O.T. damage by shorting out overload devices.
4. *Don't* disconnect the H.O.T. plate cap to kill high voltage. Use the method recommended by the set manufacturer.
5. *Don't* replace an H.O.T. without adjusting the horizontal-efficiency coil for correct cathode current.

Observing these precautions will help you to obtain maximum efficiency and longer life from the horizontal output tube. This is the latest in RCA's continuing series of color TV service hints. You will find your RCA tube distributor your best source for quality RCA receiving tubes for color TV, black and white TV, Radio and hi-fi. To help keep your customers happy, and avoid callbacks, always replace with RCA receiving tubes.

RCA ELECTRONIC COMPONENTS AND DEVICES, HARRISON, N. J.



The Most Trusted Name in Electronics